

# **HD2010UC**

*Integrating Sound Level Meter*

**ENGLISH**

Our instruments' quality level is the results of the product continuous development. This can bring about differences between the information written in this manual and the instrument that you have purchased. We cannot entirely exclude errors in the manual, for which we apologize. The data, figures and descriptions contained in this manual cannot be legally asserted. We reserve the right to make changes and corrections without prior notice.

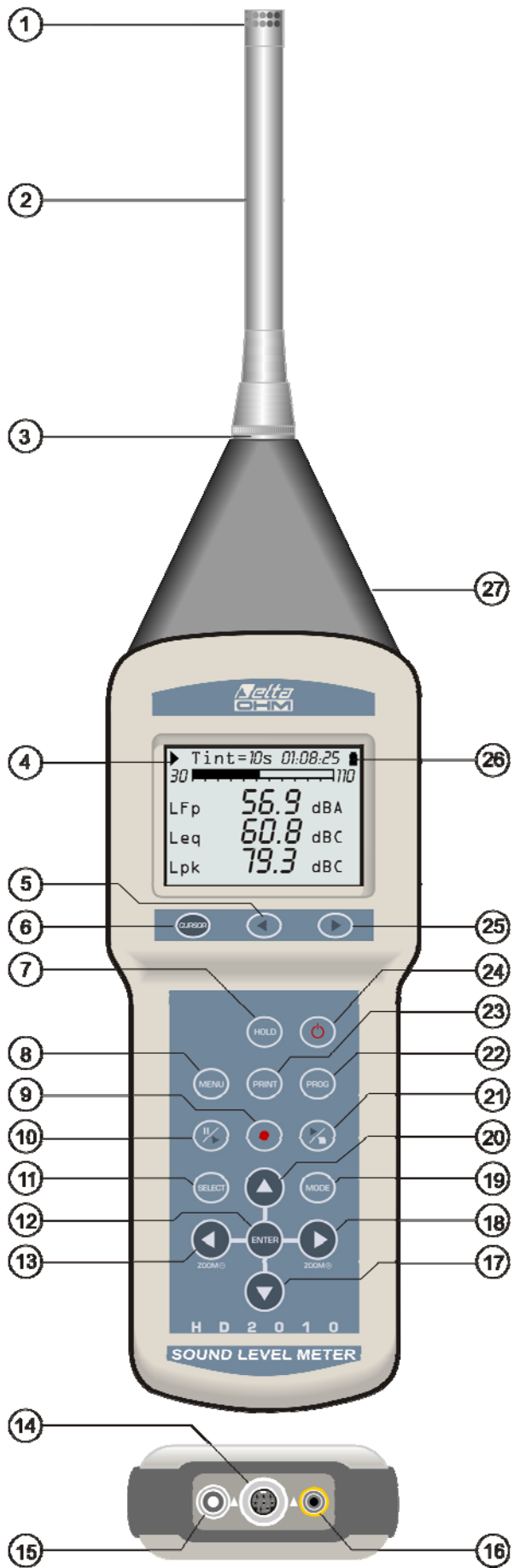

1. Microphone.
2. Preamplifier.
3. Preamplifier or extension cable connector.
4. Symbol showing measurement status: RUN, STOP, PAUSE, RECORDING or HOLD.
5. Keypad **LEFT** key: in graphic mode, it moves the selected cursor towards lower values.
6. Keypad **CURSOR** key: in graphic mode, it allows to select one or both of the two cursors.
7. **HOLD** key: it temporarily stops display updating.
8. **MENU** key: it activates the different configuration menus of the instrument.
9. **REC** key (recording): combined with START/STOP/RESET, it activates data recording on memory (with “Advanced Data Logger” option). When pressed for at least 2 seconds, the displayed data can be stored in memory as a single record; alternatively, the Auto-Store mode can be activated.
10. **PAUSE/CONTINUE** key: pauses integrated measurements. From PAUSE mode, integrated measurements can be resumed by pressing the same key. In PAUSE mode, press START/STOP/RESET to reset measurements.
11. **SELECT** key: enables modification mode of displayed parameters by selecting them in sequence.
12. **ENTER** key. It confirms entered data or edited parameters.
13. **LEFT** key: in the menu, it is used when editing parameters with attribute. In graphic mode, it reduces the vertical scale.
14. M12 connector for multi-standard serial port, RS232C and USB.
15. Auxiliary power supply connector.
16. DC output connector (Ø 2.5mm jack).
17. **DOWN** key: in the menu, it selects the next line or decreases the selected parameter. In graphic mode, it increases the vertical scale levels; the graph is shifted downwards.
18. **RIGHT** key: in the menu, it is used when editing parameters with attribute. In graphic mode it extends the vertical scale.
19. **MODE** key: if “Advanced Data Logger” is installed, selects in circular order the instrument’s different view modes, from the display of 3 channels in numeric format, to the profile (“Data Logger” option), to the statistics screens (“Advanced Data Logger” option”).
20. **UP** key: in the menu, it selects the previous line or increases the selected parameter. In graphic mode, it decreases the vertical scale levels; the graph is shifted upwards.
21. **START/STOP/RESET** key: when pressed in STOP mode, it starts the measurements (RUN mode). In RUN mode, it stops the measurements. When pressed in PAUSE mode, it resets the integrated measurements, such as Leq, SEL, MAX/MIN levels, etc.
22. **PROG** key: activates the program selection mode.
23. **PRINT** key: transfers the displayed data to the serial port. When pressed for more than 3 seconds, it enables the continuous printing (Monitor). Monitoring will be stopped by pressing the key once more.
24. **ON/OFF** key: turns the instrument on and off.
25. Keypad **RIGHT** key: in graphic mode, it moves the selected cursor towards higher values.
26. Battery symbol: indicates the battery level. The more the symbol is empty, the more the battery has run down.
27. **LINE**: un-weighted input or output connector (Ø 3.5mm jack).

## CONNECTOR FUNCTION

The instrument is equipped with five connectors: one in front, one to the side and three at the bottom. The figure on page 2 shows:

- n. 3 - 8-pole DIN connector for preamplifier or extension cable. The connector, located on the instrument front face, has a positioning notch and a screw ring nut to ensure proper locking.
- n.14 - M12 connector for RS232C multi-standard serial port and USB. For the connection to a PC's RS232 port you have to use the dedicated serial null-modem cable (code HD2110/RS), fitted with a 9-pole female connector. As alternative the sound level meter can be connected to a PC USB port by using the dedicated cable (HD2110/USB), fitted with type A USB connector.
- n.15 - Male connector for external power supply ( $\varnothing$  5.5mm-2.1mm socket). It requires a 9...12Vdc/300mA power supply. The positive (pole) power supply must be connected to the central pin.
- n.16 - Jack ( $\varnothing$  2.5mm) or the analogue (DC) A weighted output with FAST constant time updated 8 times/s.
- n.27 - Jack ( $\varnothing$  3.5 mm) for the analogue (LINE) un-weighted output placed on the right side of the conical part/detail.

# CERTIFICATO DI CONFORMITÀ DEL COSTRUTTORE

MANUFACTURER'S CERTIFICATE OF CONFORMITY

rilasciato da

issued by

**DELTA OHM SRL STRUMENTI DI MISURA**

**DATA**

2012/05/29

DATE

Si certifica che gli strumenti sotto riportati hanno superato positivamente tutti i test di produzione e sono conformi alle specifiche, valide alla data del test, riportate nella documentazione tecnica.

*We certify that below mentioned instruments have been tested and passed all production tests, confirming compliance with the manufacturer's published specification at the date of the test.*

Le misure effettuate presso un Laboratorio di Taratura Accredia sono garantite da una catena di riferibilità ininterrotta, che ha origine dalla taratura dei campioni di prima linea del Laboratorio presso l'istituto metrologico nazionale.

*Measurements performed in an Accredia Calibration Laboratory are guaranteed by a uninterrupted reference chain which source is the calibration of the Laboratory first line standards at the national metrological institute.*

**Tipo Prodotto:**

**Fonometro Integratore**

*Product Type:*

*Integrating sound level meter*

**Nome Prodotto:**

**HD2010UC**

*Product Name:*

**Responsabile Qualità**

*Head of Quality*

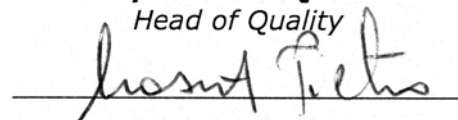

**DELTA OHM SRL**

**35030 Caselle di Selvazzano (PD) Italy**

**Via Marconi, 5**

Tel. +39.0498977150 r.a. - Telefax +39.049635596

Cod. Fisc./P.Iva IT03363960281 - N.Mecc. PD044279

R.E.A. 306030 - ISC. Reg. Soc. 68037/1998

## INTRODUCTION

The HD2010UC is an integrating portable sound level meter performing statistical analyses. The instrument has been designed combining price competitiveness and simplicity of use. Attention has been paid to the possibility of updating the instrument, and the HD2010UC can be integrated, at any time, with other options like “Advanced Data Logger” to extend its application scope. The firmware can be upgraded directly by the user using the NoiseStudio program supplied with the instrument. The HD2010UC conforms to IEC 61672-1 of 2002, IEC 60651 and IEC 60804 specifications with class 2 or class 1 tolerances. The acoustic calibrator complies with IEC 60942 class 2 or class 1 specifications.

The HD2010UC is an integrating sound level meter and analyzer suitable for the following applications:

- Assessment of the environmental noise level,
- Occupational noise measurements at the workplace (according to ISO9612)
- Measurement at the workplace,
- Selection of personal protective equipment,
- Production quality control,
- Measurement of machine noise.

With the optional “Advanced Data logger” function the sound level meter is able to perform the following task

- Environmental noise monitoring,
- Analysis of sound events,
- Complete statistical analysis with percentiles calculation from  $L_1$  to  $L_{99}$ .

Using a HD2010UC you can measure the sound level by programming 3 parameters and freely selecting the frequency weightings and time constants. You can measure parameters such as  $L_{eq}$ , SEL and maximum and minimum sound levels with integration times from 1 second to 99 hours. If an undesired sound event produces an over-load indication, or simply alter the result of an integration, its contribution can be excluded using the versatile Back-Erase function.

The measured sound levels can be recorded in the large non-volatile memory in order to be transferred to a PC using the supplied NoiseStudio program.

For long term noise monitoring needs, it's possible to increase the HD2010UC storing capacity with the optional HD2010MC Secure Digital memory card reader. This device is supplied complete with a 2GB memory card.

As a statistical analyzer, the HD2010UC samples the sound signal 8 times per second with A-frequency weighting and FAST constant, and it analyzes it statistically in 0.5 dB classes. It is possible to display up to 3 percentile levels between  $L_1$  and  $L_{99}$ .

For further analysis, the LINE un-weighted output allows recording the sound signal either on tape or directly on a PC equipped with a audio acquisition card.

The high speed of the USB interface combined with the flexibility of the RS232 interface allows quick data transfers from the sound level meter to the PC mass storage, but can also control a modem or printer. For example, in case of lengthy recordings, you can activate the “Monitor” function. This function allows to send the displayed data to a PC via the RS232 serial interface, to be directly stored on the PC mass storage.

The sound level meter can be completely controlled by a PC through the multistandard serial interface (RS232 and USB) by using a special communication protocol. Through the RS232 interface, the sound level meter can also be connected to a PC via modem.

The calibration can be made either using the provided acoustic calibrator (type 1 according to IEC 60942) or the built-in reference generator. The electric calibration employs a special preamplifier and checks the sensitivity of the measuring channel, microphone included. A protected area in the non-volatile memory, reserved to factory calibration, is used as a reference in the user's calibrations, allowing keeping instrument drifts under control and preventing the instrument from wrong calibrations. The check of the complete sound level meter functionality can be made directly by the user, on site, thanks to a diagnostic program.

The HD2010UC sound level meter can perform the measurements required to evaluate workers' noise exposure (ISO 9612/11 and D.Lgs.81/08). The selection of the personal protective equipment can be carried out, according to UNI EN 458, through comparison of the A and C weighted equivalent levels that can be measured simultaneously (SNR method). The noise source impulsivity is easily evaluated (according to UNI9432) measuring the equivalent sound pressure level A weighted with Impulse time constant (LAeqI).

The class 1 HD2010UC sound level meter with the "Advanced Data Logger" option is suitable for sound level monitoring and acoustic mapping. Using the "Advanced Data Logger" option, it can also perform assessments of the acoustic climate with capture and analysis of sound events. When measuring traffic noise near airports, railways and roads, the sound level meter can be used as a multi-parameter sound recorder, combining statistical analysis features. Remote electrical calibrations and diagnostic tests can be executed using its remote control capabilities.

The HD2010UC can be configured in accordance with different customers' needs: the available options can be activated on the new instrument, as well as, later on, when requested by the user. The provided options are:

▪ **"Advanced Data Logger" option**

Display and recording of the A-weighted sound level profile with FAST time constant, sampled 8 times per second.

Storage of the profiles of 3 programmable parameters, sampled twice per second. Simultaneously, the profiles of 3 programmable parameters are recorded at 2 samples/second. The HD2010 sound level meter changes into a sound level logger capable of storing 4 parameters for more than 23 hours. Impulsive events can be easily identified thanks to the possibility of analysing the profile of the A-weighted sound level with FAST, SLOW, and IMPULSE constants.

A second recording mode allows storing 3 parameters programmed together with the average spectra, at intervals programmable from 1 second up to 99 hours. In this recording mode, you can store 3 parameters according to intervals of 1 minute for over 80 days using the supplied memory (4 MB expandable to 8 MB). The sound level meter automatically resets all integrated levels at the beginning of each acquisition interval.

Recordings can later be searched in the memory and viewed on the graphic display using the "replay" function, which reproduces the time trend of the sound trace.

The HD2010UC sound level meter with the "Advanced Data Logger" option has more sound level analyzer functions.

- Statistical analysis is available graphically in the form of the *sound level distribution of probabilities* and the *percentile levels graph*.
- Parallel to the normal sound level profiles recording mode, you can select a *report recording*, programmable according to intervals from 1s to 1 hour, with 5 integrated parameters and the sound level distribution of probabilities.
- It is possible to enable a *trigger feature* to capture sound events, and false events can be filtered by requiring that the sound level variation be of a certain length. You can record 5 integrated parameters per each event, and the sound level distribution of probabilities being sampled during the event. The event parameters recording does not exclude logging of profiles and reports. The event trigger feature can also be activated by pressing a key. Thanks to "Advanced Data Logger" option, the HD2010UC can acquire the noise profile of 3 acoustic de-

scriptors in parallel with reports sequences with 5 dedicate parameters and complete statistical analysis. Moreover, during data logging, the trigger function enables user to identify events recording 5 acoustic parameters together with statistical descriptors of each event.

- During recording, up to 9 different markers are available in order to signal the occurrence of particular situations to be considered during the traces analysis phase.
- A *timer* programs delayed start of capture.

- ***“Memory module” option***

This option doubles the memory capacity from 4MB to 8MB. “Advanced Data Logger” option required.



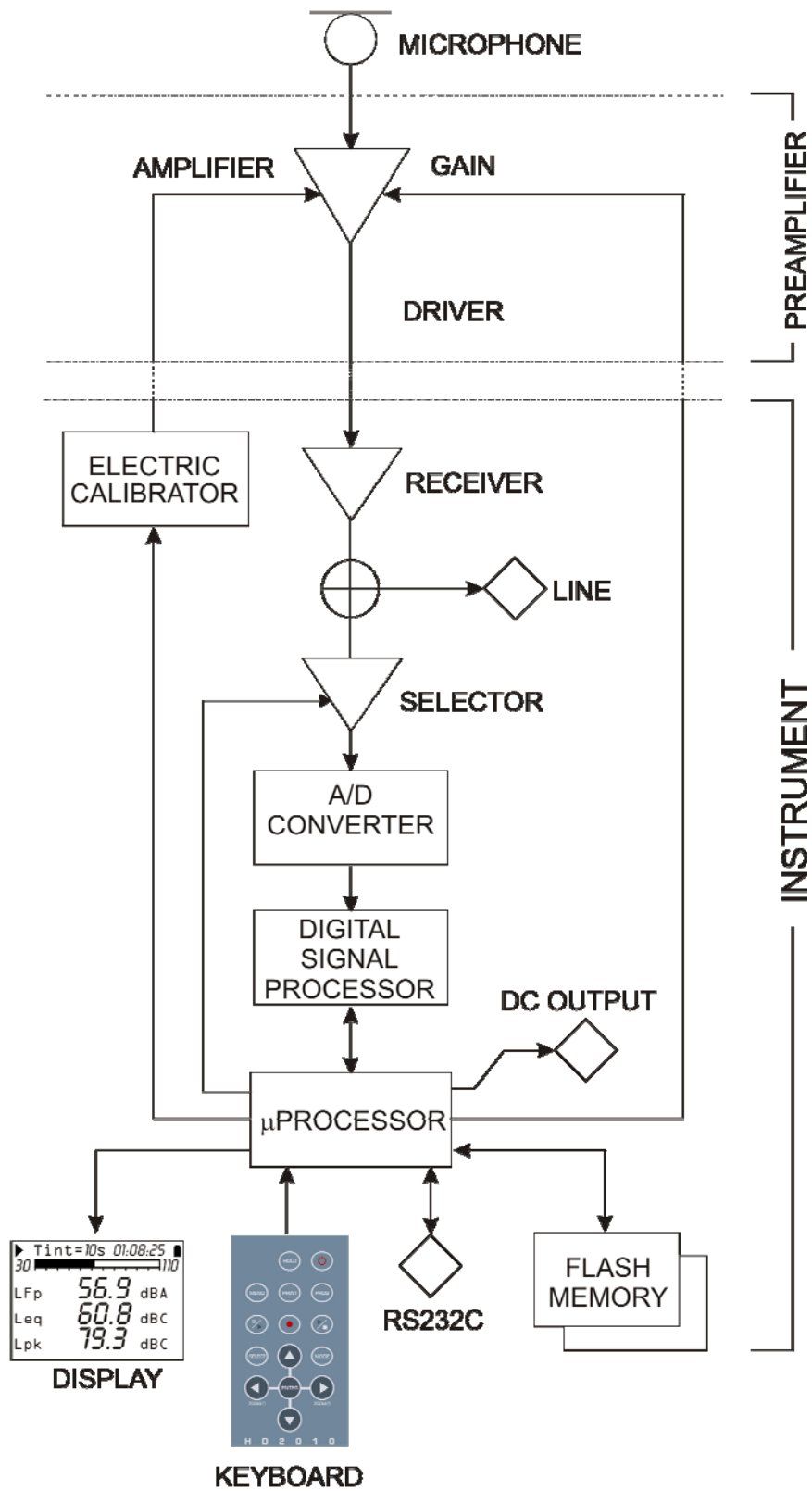

The block diagram shows the main elements of the HD2010UC sound level meter.

## THE MICROPHONE

The UC52 condenser microphone is pre-polarized and has a ½” standard diameter. The frequency response in free field is flat from 20Hz to 16kHz for type 1 sound level meter version HD2010UC Kit1 (UC52/1). Version used for type 2 sound level meter version is flat from 25Hz to 10KHz

## THE OUTDOOR MICROPHONE UNIT HD WME

The microphone unit HD WME is suitable for long term outdoor noise measurements, including from fixed unattended station. The unit is adequately protected from rain and wind; the heated preamplifier allows performing measurements within a wide weather condition range.

The special preamplifier is fitted with a calibration circuit that uses a charge partition technique in order to calibrate the unit, inclusive of the microphone capsule. The output driver allows guiding cables up to 10m in length, without important losses.

The “free field” response of the UC52 microphone fitted with the HD WME, maintains the Class 1 specifications of the microphone only. Its ease of assembly and disassembly mean the electro-acoustic characteristics periodic check can be made like using a normal measurement microphone.



**HD WME unit must be positioned in vertical position** to fulfill correctly its function as weather protection. Used in this way it can measure both community and airplane noise (90° and 0°). Delta Ohm sound level meters apply spectral corrections to measurements in order to comply with IEC61672 type 1 and type 2 tolerances.

Installation and uninstallation procedure is very easy; in this way periodical acoustic verification (using a calibrator) of the microphone is as simple as for a standard measurement microphone.

The unit is composed of a central body plus the following components:

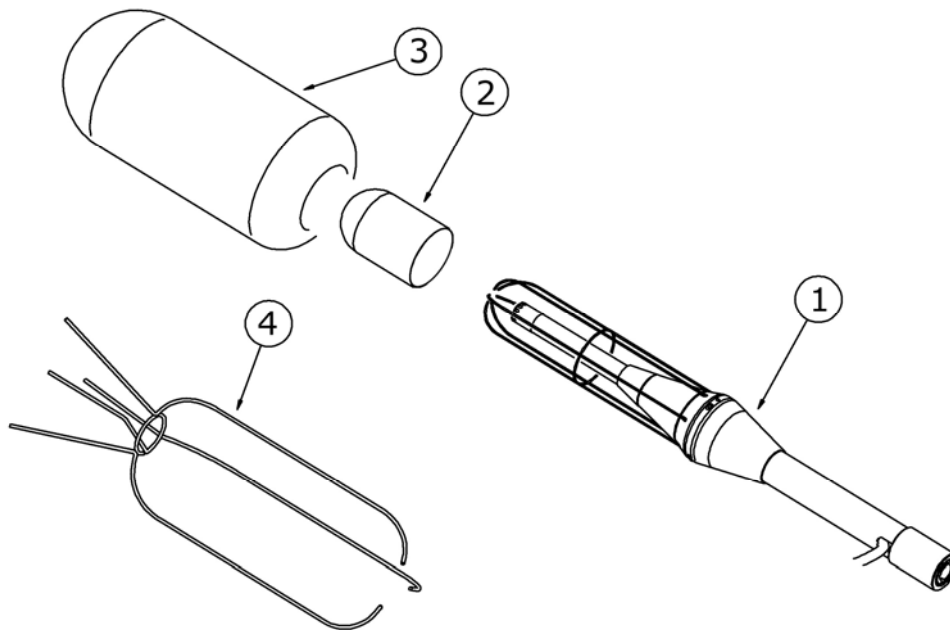

- **HD SAV3:** wind-screen (3)
- **HD WME1:** ant-bird spike (4)
- **HD WME2:** rain shield (2)
- **HD WME3:** stainless steel support (1)
- **Microphonic capsule** with optimized free field correction
- **Microphone preamplifier:**
  - HD2010PNE2W: heated preamplifier for UC52 microphone including CTC calibrator and driver for up to 10m extension cable.
- **Extension cable** standard 5m length (10m on request).

For detailed information on the use of HD WME unit, please refer to the specific part of this manual on page. 45; for information on assembling and disassembling the unit please refer to appendix on page 113.

## THE PREAMPLIFIER

The HD2010PNE2 preamplifier amplifies the weak signal provided by the microphone. The preamplifier has a gain selectable between 0 and 10 dB and is supplied with a charge partition calibration device which allows to measure the frequency response of the whole amplification chain, microphone included (diagram described on page.49).

The output driver allows transmitting the microphone signal via a cable to a distance up to 10m. HD2010PNE2 preamplifier together with UC52 microphone can measure signals up to 140 dB.

The following models are available:

- **HD2010PNE2:** connector for ½" UC52 microphone and driver for up to 10m extension cables. This preamplifier, supplied with CTC electric calibration device, can be directly plugged into the HD2010UC sound level meter or connected via extension cable (up to 10mt).
- **HD2010PNE2W:** heated preamplifier with connector for ½" UC52 microphone and driver for extension cables. This preamplifier, supplied with CTC calibration device, can be connected to sound level meters using the 5mt supplied extension cable (10m as option).

## THE INSTRUMENT

The signal of the preamplifier comes to the instrument receiver and its output is sent to the LINE connector and to the A/D converter input. The instrument can be set to use the LINE channel in place of the signal coming from the preamplifier.

The A/D converts the analogue signal into the numeric format at 20 bits. The measurement dynamics, exceeding 140 dB, is divided into 5 ranges using a variable gain amplifier with steps of 10 dB, between 0 dB and 20 dB, positioned at the input.

The signal of the preamplifier comes to the instrument receiver and its output is sent to the LINE connector and to the A/D converter input. The instrument can be set to use the LINE channel in place of the signal coming from the preamplifier.

The A/D converts the analogue signal into the numeric format at 20 bits. The measurement dynamics, exceeding 140 dB, is divided into 5 ranges using a variable gain amplifier with steps of 10 dB, between 0 dB and 20 dB, positioned at the input.

The levels with (A, C and Z) wideband frequency weighting are calculated in parallel in the DSP). Peak (C and Z) levels are also calculated. The levels calculated by the DSP are transmitted to the microprocessor for further processing, ready to be displayed, stored and printed.

The microprocessor controls all the instrument processes: management of the electrical calibrator, Flash memory, display, keyboard and multi-standard serial interface (RS232 and USB).

The microprocessor also supplies the electrical signal corresponding to the A weighted instant level with FAST time constant, sent to DC output.

## DESCRIPTION OF DISPLAY MODES

The HD2010UC measures simultaneously 3 selectable parameters (statistic ones too) and displays them at a fixed frequency corresponding to 2 measurements/s; simultaneously (with “Advanced Data Logger” option) measures the A weighted sound pressure level with FAST time constant and displays it at 8 samples/s; as a statistic analyser, it calculates the probability distribution and the percentile levels (cumulative distribution). To be able to display all these data, the HD2010UC, provides 4 different display modes as shown in the figures below.

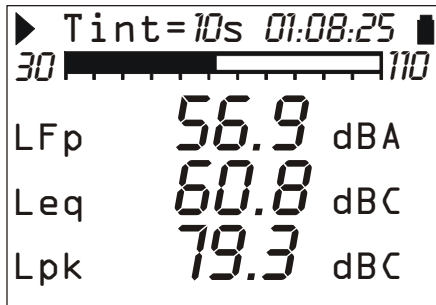

Fig. 1 - SLM

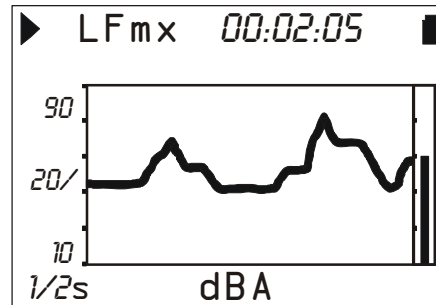

Fig. 2 - Time Profile

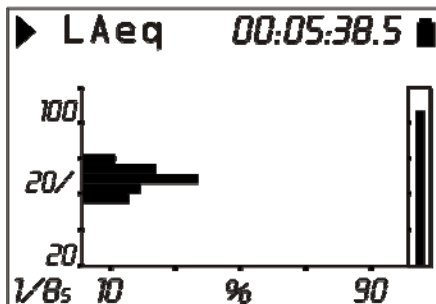

Fig. 3 - Probability distribution

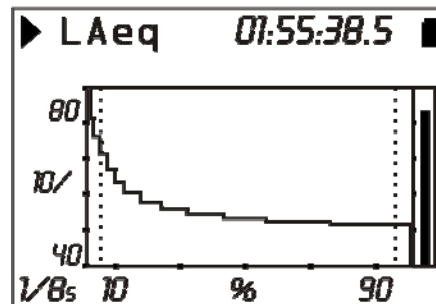

Fig. 4 - Percentiles Levels

Press **MODE** at any time to jump from a screen page to the next one. The display will show: first the **SLM** screen with 3 measuring parameters in numeric format and, if the “Advanced Data Logger” option is enabled, the **Profile** screen with the A weighted sound pressure level with FAST time constant ( $L_{AFp}$ ), the **Probability distribution** and the **Percentile Levels** screens. Upon power on, the sound level meter displays the SLM screen.

Some indications are shown in all modes. They are (see the figure on the right):

- Measurement status indicator
- Overload/Under-range indicator
- Battery level indicator

The first symbol in the left corner at the top shows the measurement status of the sound level meter.

- **RUN**: the instrument is measuring.
- **PAUSE**: the calculation of integrated measurements and the recording of measurement have been suspended. Instantaneous parameters are still being measured and displayed.
- **REC**: the instrument is measuring and recording.
- **STOP**: the instrument is not making any measurement.

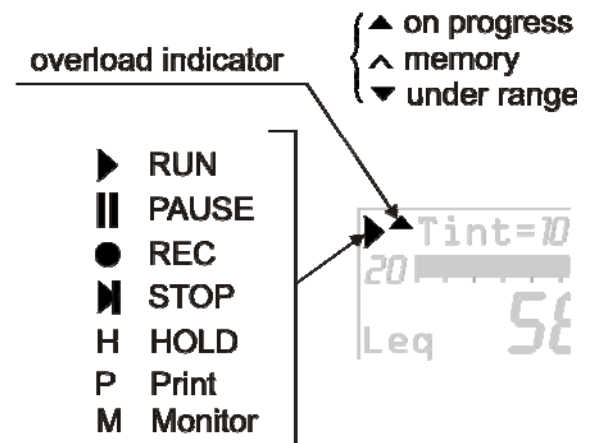

- **HOLD**: the calculation of integrated measurements has come to the end of the set integration interval, or HOLD was pressed.
- **P (Print)**: indicates that printing is in progress.
- **M (Monitor)**: indicates (flashing) that continuous data printing has been started.
- **R (Replay)**: appears (flashing) when the “Memory Navigator” program is in use (“Advanced Data Logger” option required), to view a file saved in the instrument memory (see page.42).

Just on the right of the symbol indicating the logging mode, there is the symbol showing a possible **overload** or under-range. An arrow directed upwards indicates that the input level has exceeded the maximum measurable level, while an arrow directed downwards indicates that the input level is lower than the minimum measurable level.

The maximum measurable level corresponding to the selected measurement range is given in the technical specifications (see page 74). The minimum measurable level is 80 dB lower than the maximum one. The noise levels for each frequency weighting are listed in the technical specifications. Using an appropriate parameter (MENU >> Instrument >> Measurement >> Overload Level) you can program the maximum measurable limit at lower levels (chapter on page 74).

An empty arrow indicates that the limit has been exceeded, while a full arrow indicates that the overload is in progress.

The **integration time Tint**, programmable between 1s and 99h, is displayed to the right of the overload indicator. When the integration mode is set on MULT, the “Tint” symbol on the SLM will flash (see the “DESCRIPTION OF THE DIFFERENT INTEGRATION MODES” chapter on page 26).

In the right corner at the top, there is the **battery symbol**. The more the symbol is empty, the more the battery has run down. When the instrument autonomy reaches 10%, corresponding to about 30 minutes, the battery symbol will start flashing. A protection device prevents the instrument from making measurements with insufficient battery levels and automatically switches off the instrument when the battery level is at the minimum.

The battery level, expressed in percentage, is visible in the menu main screen page and in the program page; press MENU and PROG to access them. To jump back to the measurement screen, press MENU and PROG again.

Pressing **SELECT**, you will select in sequence the parameters relevant to the displayed page. While the selected parameter flashes, you can change it with the UP and DOWN keys. Press ENTER to quit the selection mode (automatic exit after 10s).

In graphic display mode, use the UP, DOWN, LEFT and RIGHT keys to change the vertical scale parameters. The LEFT and RIGHT keys reduce and expand the vertical scale, while the UP and DOWN keys decrease and increase the levels of the vertical scale; the graph is so shifted upwards or downwards, respectively.

## SLM (SOUND LEVEL METER)

This is the display mode upon power on.

Three parameters (selectable among the following ones) can be displayed simultaneously:

- *Instantaneous* acoustic parameters such as  $L_p$ ,  $L_{eq}$ (Short) and  $L_{pk}$ . The instantaneous pressure level is displayed as the maximum level reached every 0.5s.
  - *Integrated* acoustic parameters with wideband frequency weightings, such as  $L_{pmax}$ ,  $L_{eq}$ ,  $L_{leq}$  and  $L_{pkmax}$ , updated every 0.5s.
  - Percentile levels selectable between  $L_1$  ad  $L_{99}$ .
  - Sound exposure level.
  - Daily personal exposure level.
  - Dose and daily Dose with programmable Exchange Rate, Criterion and Threshold Levels.
  - Overload Time (in %).

The display is updated every 0.5 seconds.

The data recording depends on the integration mode selected (single or multi) and on the activation or not of the auto-store mode. (see the chapter “DESCRIPTION OF THE DIFFERENT INTEGRATION MODES” on page 26).

		Auto-Store: OFF	Auto-Store: ON
Integration	SINGLE	Recording twice a second of the 3 parameters and 8 times a second of LAF. Automatic Stop at the end of the set integration interval.	Automatic recording of SLM page at the end of the set integration interval.
	MULTIPLE	Recording twice a second of the 3 parameters and 8 times a second of LAF. Automatic reset of integrated levels at every integration interval.	Automatic recording of the SLM screen at intervals equals to the set integration time. At the beginning of each period, integrated levels and spectra are set to zero.

## DISPLAY DESCRIPTION

Left at the top of the display there are the recording status symbol and the overload or under-range indicator (described at the beginning of this chapter). In the midst there is the integration interval and on the right the acquisition time (hours:minutes:seconds). When the integration mode is set on MULT (MENU>>General>>Integr.Mode:MULT), the “Tint” symbol flashes. The battery symbol is in the right corner, indicating battery level.

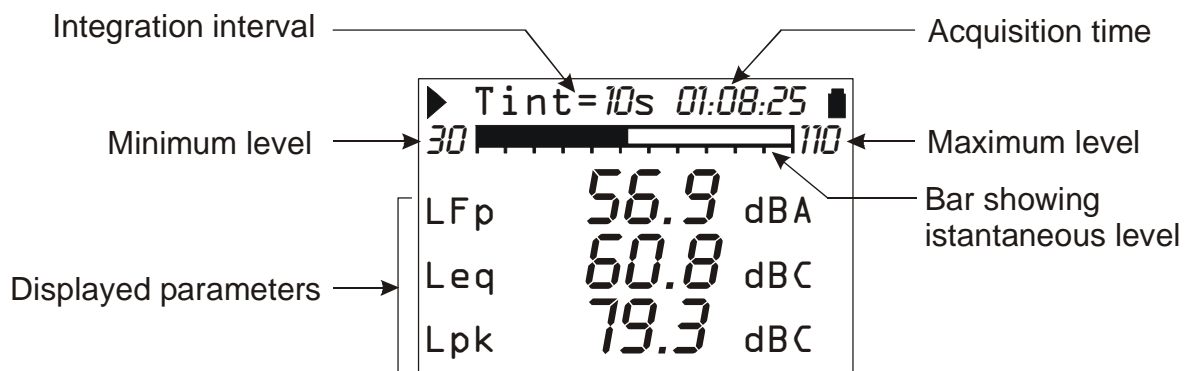

The “analogue bar” shows the unweighted sound pressure instantaneous level in an 80 dB interval.

Three measuring parameters are displayed under the analogue bar. All displayed parameters can be freely selectable among the available ones. There are no restrictions in the selection of frequency weightings. Measuring parameters are displayed with a shortened label, followed by the numerical value, by the unit of measurement, and, when necessary, by the frequency weighting. The correspondence between the label and the effective parameter is to be found on page 98.

Integrated parameters like Leq (and Lmax or Lmin), which imply the accumulation of the sampled sound levels, are displayed with a series of dashes (----) until the level remains lower than the minimum measurable level.

Before starting a new logging, the sound level meter automatically resets all measurements. If the multiple integration mode is enabled (MENU >> Instrument >> Measurements >> Integration Mode: MULT), integrated levels will be automatically set to zero at regular intervals equal to the set integration time *Tint*.

If the “Advanced Data Logger” option is installed, with the *Continuous Recording* mode a series of values is stored every 0.5s together with the parameter displayed in the PROFILE screen, which corresponds to the A weighted sound pressure level with FAST time constant, computed 8 times a second. Each sample corresponds to the highest sound level ( $L_{AFmx}$ ) calculated every 0.125s on the level measured every 7.8ms.

## SELECTING PARAMETERS

Some measuring parameters (integration interval, measuring range and the 3 parameters) can be changed directly via the SLM screen.

Pressing SELECT you choose the different parameters in sequence. While the selected parameter flashes, you can change it with the UP and DOWN keys.

If a parameter with attribute is selected, like, for example, LFp (FAST weighted pressure level), the relative frequency weighting will also flash (A in the example in the figure). In this case, pressing UP and DOWN, you can modify the selected parameter without changing the attribute; for example, if you press DOWN, you can go from LFp A weighted to LSp A weighted. Pressing RIGHT you’ll jump to the attribute selection, which will be the only one to flash. Use then the UP and DOWN keys to change the attribute. For example, if you press UP, you can go from A weighted LSp to Z weighted LSp.

Pressing SELECT let you choose the next parameter; pressing ENTER, or automatically after approximately 10s, will let you exit the selection mode.

Also the *integration mode* (see page 26) can be set using the LEFT and RIGHT keys: press SELECT to choose the integration interval. When the integration interval numeric value flashes, press RIGHT to set the *multiple* integration mode or LEFT to set the *single* integration mode. When the integration mode is set on MULT, the “Tint” symbol flashes.

**Parameters can be modified only when the instrument is in STOP mode:** if you try to make changes to any of the parameters while the instrument is in a status other than STOP, you will be asked to stop the measurement in progress: pressing YES will stop recording and will allow you to go on modifying parameters; pressing NO recording will continue without interruption.

The above settings can be made through the instrument configuration menus. See a detailed description on page.32.

## BACK-ERASE FUNCTION (DATA EXCLUSION)

To stop a measurement in progress when recording, press the **PAUSE/CONTINUE** key.

All data logged until the moment key was pressed are used for calculation of integrated parameters. However, there are some cases when it is useful to clear the measurements recorded just



before pressing PAUSE, for example, because they were caused by unexpected events and not characterizing the sound being examined.

During measurement, press PAUSE/CONTINUE: integrated measurements update will be interrupted. At this point, press the LEFT arrow to delete the last recorded data.

The integration time value will be temporarily replaced by the word ERASE followed by the time interval (in seconds) to be deleted. Use the LEFT and RIGHT keys to increase or decrease the erase interval. Displayed integrated parameters change accordingly, allowing choosing the erase time depending on the effective need. When pressing PAUSE/CONTINUE again, measurement will start again and the integrated parameters will have been removed from the selected interval.

The erase maximum time, divided into 5 steps, is set from menu: MENU >> Instrument >> Measurement >> Max Back-Erase. Settable values are: 5, 10, 30 or 60 seconds, with 1s, 2s, 6s or 12s steps, respectively.

## TIME PROFILE MODE (REQUIRES THE “ADVANCED DATA LOGGER” OPTION)

This display mode, available if “Advanced Data Logger” is installed, presents the time profile of the A weighted sound pressure level with FAST time constant ( $L_{AFp}$ ). The integration time is equal to 1/8s and the last 100 measured samples are displayed.

The HD2010UC sound level meter calculates the sound level 128 times a second and displays the maximum level at intervals equal to 125ms.

Pressing HOLD, the display update will be stopped; however, the instrument continues measuring and pressing HOLD again will restart display updating.

The HOLD status does not affect neither *Monitor* (continuous printing) nor recording operations. When the continuous recording is activated with the single integration mode, the integration time acts like a timer for data acquisition, stopping automatically the measurement when the time is elapsed.

This screen-page is not recorded in the Auto-Store mode.

## DISPLAY DESCRIPTION

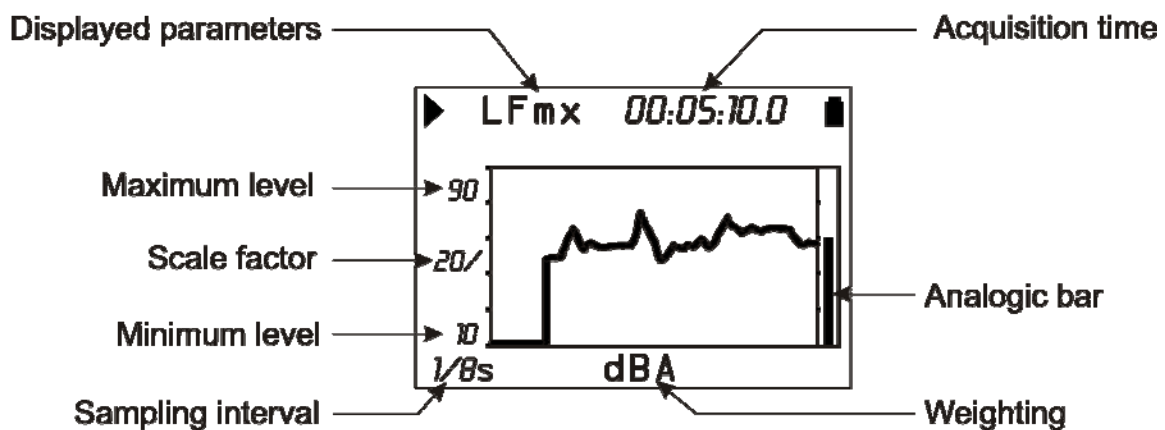

Fig. 5 - Description of the Profile mode display

The Fig. 5 presents the time profile of the A weighted sound pressure level with FAST time constant.

The integration interval is shown in the left corner at the bottom of the display. Always at the bottom, in the centre, the display shows the measurement unit and the frequency weighting of the measuring parameter

The amplitude of the vertical scale of the displayed graph corresponds to 5 divisions. The amplitude of each division is called “scale factor” of the graph and appears in the middle of the vertical axis. Using the RIGHT (zoom +) and LEFT (zoom -) keys, this parameter is selectable in real time among 20dB, 10dB or 5dB by division.

Use the UP and DOWN arrows to set the graph full scale with steps equal to the selected scale factor, starting from the instrument full scale<sup>1</sup>. In this way, the graph can be shifted UP or DOWN, depending on the key you have pressed.

An “analogue” bar indicator on the display right side provides the non-weighted instantaneous level of the input sound pressure level, as for the SLM mode bar.

During *Recording* mode, 8 values per second of the  $L_{AFp}$  level are stored together with 2 values per second of the SLM screen sound levels. Likewise, when the *Monitor* function is enabled, 4 values are sent to the interface every 0.5s.

<sup>1</sup> The instrument full scale is determined by the selection of the input gain by choosing from the menu: MENU >> Instrument >> Input gain.

The integration mode do not influence this screen recording functioning.

The sound level displayed on this screen can be used as source for the event trigger (see paragraph "EVENT TRIGGER FUNCTION" on page 24).

## **USING THE CURSORS**

To activate cursors on the graph, press CURSOR on the keypad. If you press CURSOR repeatedly, either  $L_1$  or  $L_2$  cursor, or both  $\Delta L$  cursors in "tracking" will be activated in succession: the selected cursor will flash. Use the LEFT and RIGHT arrows on the keypad to move the selected cursor on the graph.

The second line at the top of the display shows the level of the measuring parameter and the time indicated by the active cursor or the time interval and the  $L_1$ - $L_2$  level difference between the two cursors when they are both active.

The parameter level being lower than the minimum measurable level is indicated by a series of dashes (- - -).

Press CURSOR again to disable the cursors.

## STATISTICAL GRAPHS

The functioning mode with **advanced statistical analyser**, available with “Advanced Data logger” installed, allows analyses on the sound pressure level with FAST time constant (sampled 8 times per second) or short equivalent level (integrated every 0.125s) or peak level (calculated twice per second) with any frequency weighting (only C or Z for peak level).

The statistical analysis is done with 0.5dB classes for sound levels from 21dB to 140dB and provides graphic display of the sound level distribution of probabilities and percentile levels. The graphs can be enabled in Menu >> Statistical Analyzer >> Display Statistics. Disabling the displays does not influence the programmable L1–L4 percentile level calculation.

The following figure shows the level **distribution of probabilities** on the 6-minute measurement of the noise issued by a climatic room. During measurement an acoustic calibrator was switched on for about 2 minutes near the microphone.

The distribution of probabilities shows the different “population” of the examined noise clearly. From lower levels, the first peak (about 63dBA) reflects the room background noise caused by the ventilation system. The second peak (about 65dB) concerns the cooling compressor activation. The third peak (about 69dB) is the tone issued by the calibrator.

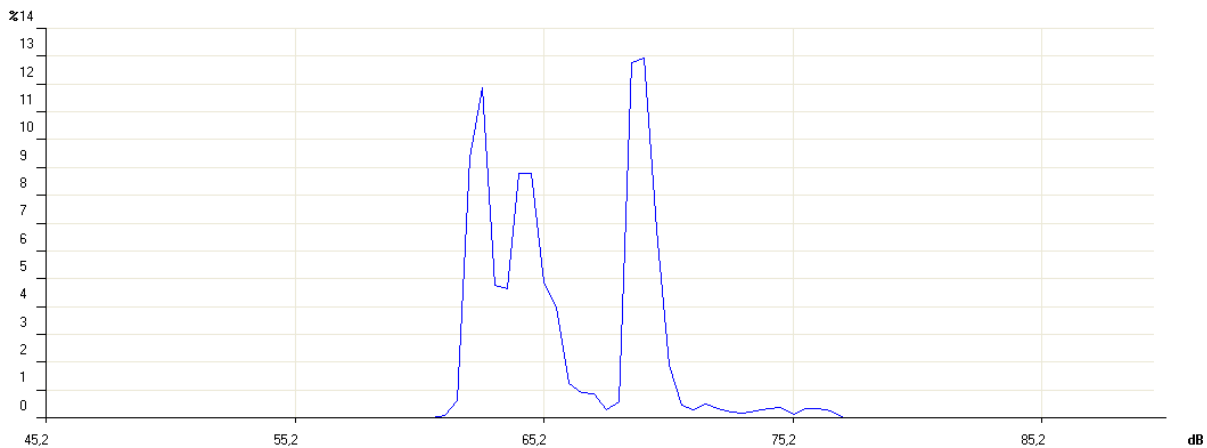

In the following figure the **cumulative distribution** for the same sample above can be seen. The cumulative distribution is built from the 100% of the levels under the measured minimum, and subtracting the probability of each you get 0 for the levels over the measured maximum.

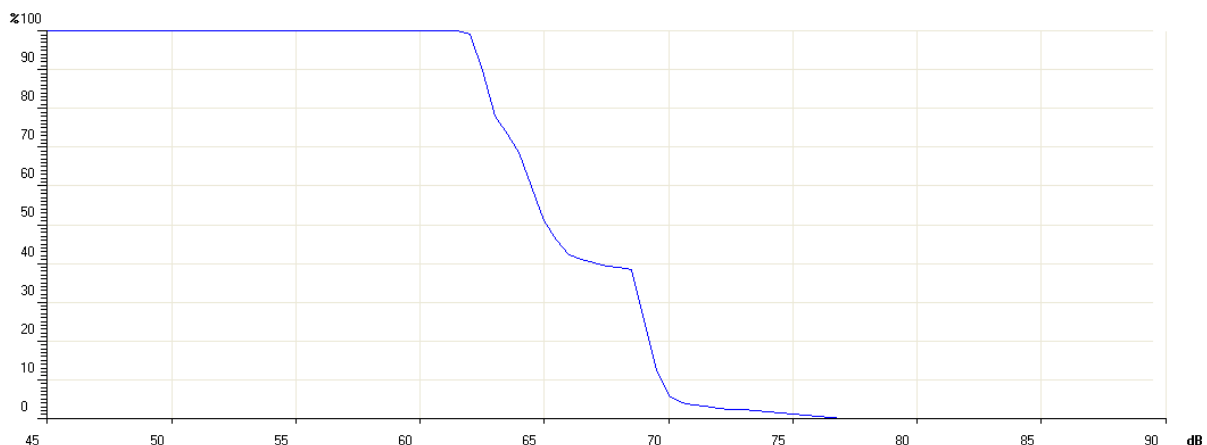

The *percentile levels* are calculated interpolating the cumulative distribution.

The statistical analyzer resets the classes at the beginning of measurement and, if no report time has been selected, it will continue accumulating the statistic until the end of the measurement. If a report time is selected (menu Main >> Measurement >> Report time) or the “multi” mode is activated, the statistic is automatically reset at the beginning of each interval.

The HOLD key does not affect this display mode.

When the continuous recording is activated with the single integration mode, the integration time acts like a timer for data acquisition, stopping automatically the measurement when the time is elapsed. When the level integration is performed in multiple mode, the statistical graphs are cleared at the beginning of every interval. These screens are not recorded in the Auto-Store mode, and can be recorded only as a single datum; therefore they are not available for continuous recording.

These display modes do not have a specific Monitor function. The statistical analysis is sent to the serial interface, together with other measurements, when the monitor function is enabled in MEASUREMENT (see paragraph "PRINT AND MONITOR FUNCTIONS" on page 29).

**Level distribution of probabilities**

This function is available with "Advanced Data Logger" installed.

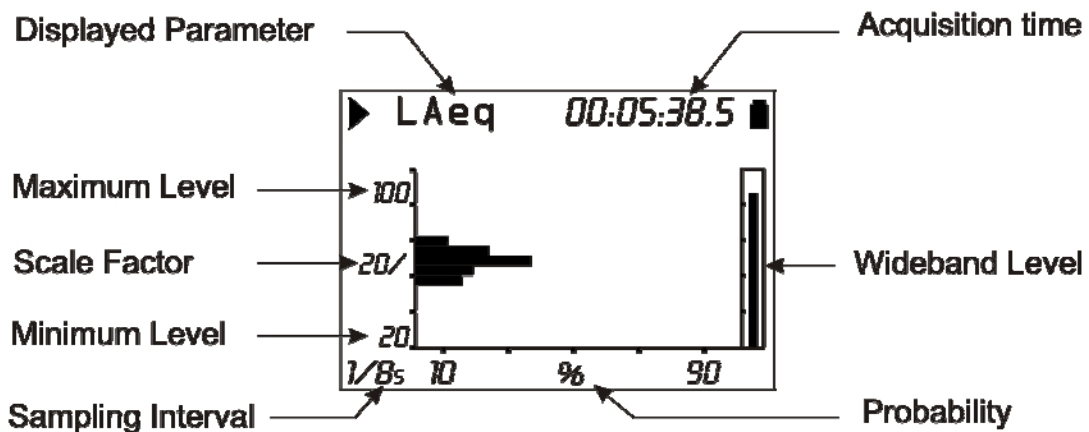

**Fig. 6 - Description of the distribution of probabilities display**

The figure shows the distribution of probabilities of the A weighted equivalent level with a 0.125s sampling interval. The vertical axis shows the sound levels in decibels and the probabilities are on the horizontal axis.

The display shows the sampling interval in the left lower corner and the chosen measurement parameter for the statistical analysis in the first line, to the left of the status indicator, and the possible overload indicator.

The amplitude of the vertical scale of the displayed graph corresponds to 5 divisions. The amplitude of each division is called "scale factor" of the graph and appears in the middle of the vertical axis. This parameter is selectable in real time among 20dB, 10dB or 5dB by division. These correspond to the 2dB, 1dB or 0.5dB classes in the graph. The scale factor can be set using the RIGHT (zoom +) and LEFT (zoom -) keys.

Use the UP and DOWN arrows to set the graph full scale with steps equal to the selected scale factor. In this way, the graph can be shifted UP or DOWN according to the pressed key.

An "analogue" bar indicator on the display right side provides the non-weighted instantaneous level of the input sound pressure level, as for the SLM mode bar.

The parameter chosen for statistical analysis can be changed without accessing the menus, but simply using the SELECT keys, the four arrows UP, DOWN, LEFT and RIGHT and ENTER (for more details, see "Selecting Parameters " on page 16).

**Using the Cursors**

To activate cursors on the graph, press CURSOR on the keypad. If you press CURSOR repeatedly, either L1 or L2 cursor, or both ΔL cursors in "tracking" will be activated in succession:

the selected cursor will flash. Use the LEFT and RIGHT arrows on the keypad to move the selected cursor on the graph.

The second line at the top of the display shows the level and central frequency of the class and the relevant probability indicated by the active cursor, or the probability for the levels in the interval between the two cursors when they are both active.

Press CURSOR again to disable the cursors.

### Percentile Levels Graph

The graphic display is available for the sound level distribution of probabilities and also for the percentile levels ("Advanced Data Logger" required).

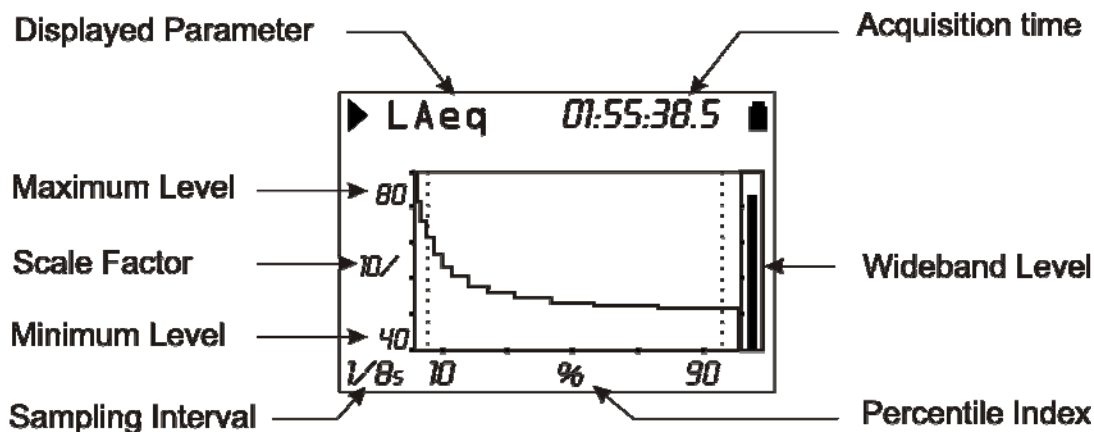

Fig. 7 - Description of the percentile level display

The figure shows the percentile levels graph corresponding to the distribution of probabilities shown in the above paragraph.

From the sound level distribution of probabilities you can calculate the *cumulative distribution of probabilities* on the same classes. The cumulative distribution is equal to 100% for the classes with levels under the measured minimum, and 0% for the classes with levels over the measured maximum. From the minimum measured level class, the cumulative distribution decreases for the relevant probability of each class until the class corresponding to the maximum measured level, where it becomes zero. The  $L_1 - L_{99}$  percentile levels are calculated interpolating the cumulative distribution of probabilities.

The vertical axis shows the sound levels in decibels and the percentile index is on the horizontal axis. The display shows the sampling interval in the left lower corner and the chosen measurement parameter for the statistical analysis in the first line, left of the status indicator and the possible overload indicator.

The amplitude of the vertical scale corresponds to 5 divisions. The amplitude of each division is called "scale factor" of the graph and appears in the middle of the vertical axis. This parameter is selectable in real time among 20dB, 10dB or 5dB by division. The scale factor can be set using the RIGHT (zoom +) and LEFT (zoom -) keys.

Use the UP and DOWN arrows to set the graph full scale with steps equal to the selected scale factor. In this way, the graph can be shifted UP or DOWN according to the pressed key.

An "analogue" bar indicator on the display right side provides the non-weighted instantaneous level of the input sound pressure level, as for the SLM mode bar.

The parameter chosen for statistical analysis can be changed without accessing the menus, but simply using the SELECT keys, the four arrows (UP, DOWN, LEFT and RIGHT) and ENTER (for more details, see "Selecting Parameters" on page 16).

### *Using the Cursors*

The CURSOR, LEFT and RIGHT keys on the keypad enable and move the cursor. The second line at the top of the display shows the percentile level indicated by the cursor. Press CURSOR again to disable the cursor.

## EVENT TRIGGER FUNCTION

The **Event trigger** function is available with the “**Advanced Data Logger**” option and can be enabled only with the single integration mode. During measurement this function can be used to isolate a sound event identifiable by *sound level variation* or by *synchronization to an external signal* or, *manually*, by pressing a key.

The acoustic descriptor used by the trigger function is selected in the PROFILE view (Menu >> Trigger >> Source: LEV). The level variation that triggers the event can be *positive* or *negative* (Menu >> Trigger >> Trigger Polarity) and the *trigger threshold* (Menu >> Trigger >> Trigger Threshold and Menu >> Trigger >> Bottom Threshold) can be different from the deactivation threshold (Menu >> Trigger >> Trigger Threshold and Menu >> Trigger >> Bottom Threshold). The following figure shows an example of a positive polarity sound event capture. The sound level ( $L_{AF}$ ) exceeds the trigger threshold for time T0 and, later, the bottom threshold for time T2.

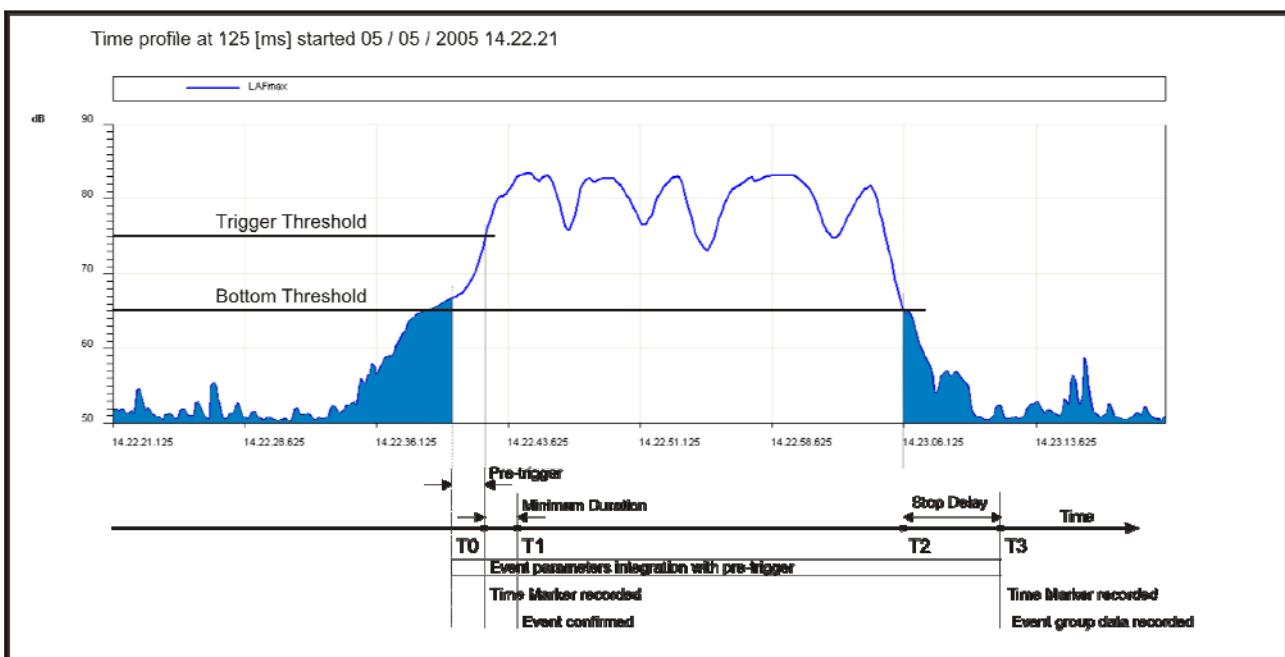

**Fig. 8** - Description of the event trigger parameters

To prevent short duration pulses being detected as sound events, a *minimum trigger duration* can be set up to a maximum of 10s (Menu >> Trigger >> Minimum Duration). If the threshold is exceeded for less than the set time, the event is neglected. Also a *minimum deactivation duration* can be set: when the deactivation threshold is exceeded, the event close is delayed for the set time, up to a maximum of 255s (Menu >> Trigger >> Stop Delay).

In the example, since the trigger conditions exceed the minimum duration, that is, they persist at least for time T1, the event levels integration begins, including the 2 seconds before the threshold is reached (*pre-trigger*). This pre-trigger time cannot be modified.

The event levels integration ends at time T3, that is, after the *stop delay* from the T2 time corresponding to the bottom threshold being reached.

The event trigger feature can be activated also by pressing the ENTER key (Menu >> Trigger >> Source: MAN). In this case the minimum duration parameter has no effect and the event begins as soon as the trigger is detected.



Per each event identified, 2010UC calculates the following:

- 5 programmable selectable parameters: maximum and minimum levels, peak level, equivalent level and SEL.
- Full statistical analysis

These parameters are not displayed but can be stored, completely or partially, at the end of each level. The menu *Recording >> Event* allows selection of the 5 parameters and memorization.

The event parameters integration begins 2 seconds before triggering. This pre-trigger time cannot be modified.

A special printing function, synchronized with the trigger, is available for communication of the event itself via RS232 (Menu >> Trigger >> Print).

If the trigger is enabled, the sound level profile is displayed with black background when the trigger is not active so as to highlight the event's portion.

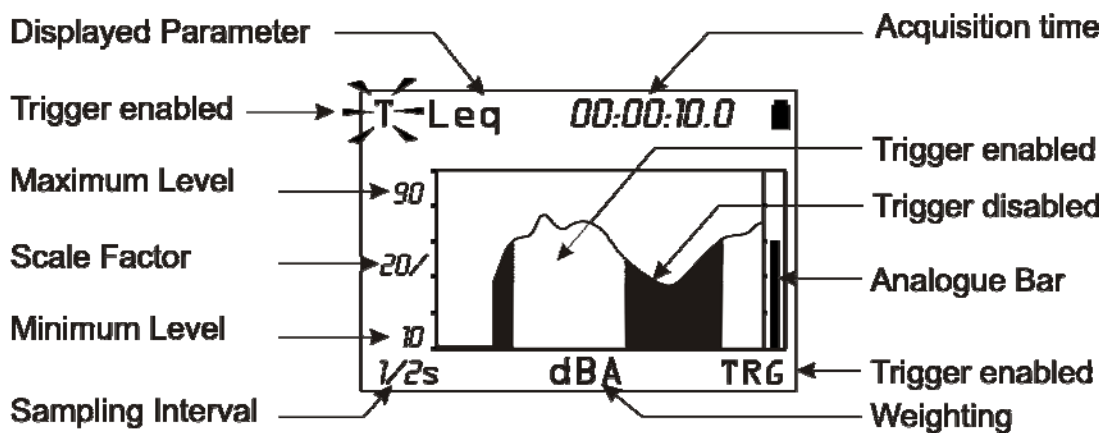
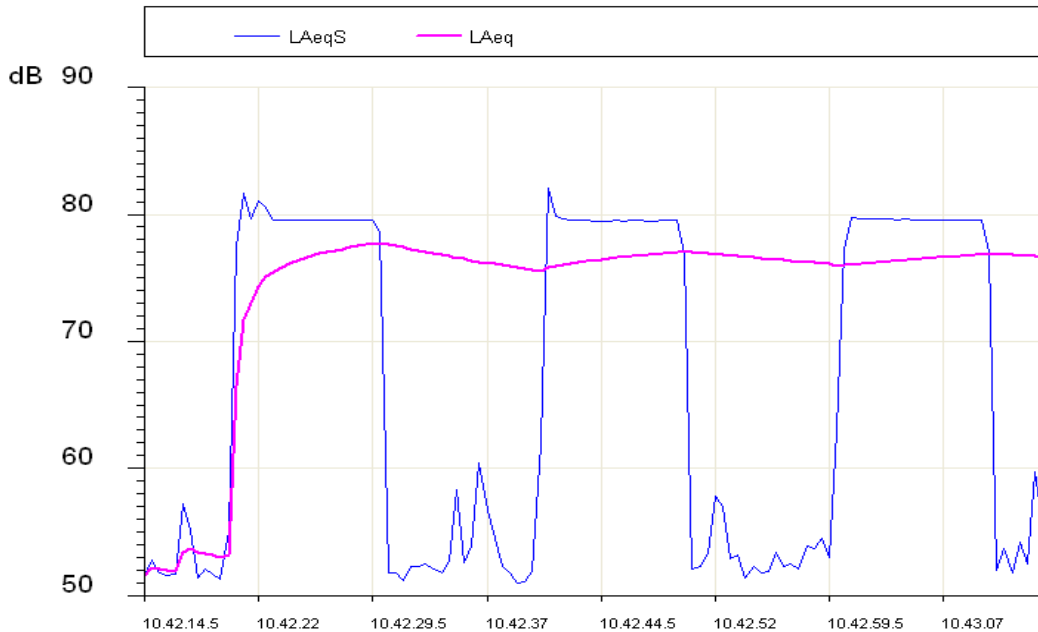

Fig. 9 - Description of the "Event trigger - display"

## DESCRIPTION OF THE DIFFERENT INTEGRATION MODES

The 2010UC makes measurements according to two different acquisition modes either **single** (standard for 2010UC) or **multiple** (“Advanced Data Logger” required).

The single integration begins by resetting the integrated levels (e.g. the Leq) and ends when the set integration time  $T_{int}$  is elapsed or when the acquisition is manually interrupted by the RUN/STOP key. The following figure shows the Leq Short profile calculated twice per second and the integrated Leq over a measurement time of 1 minute in single mode.



In the measurement time span, the Leq Short (LAeqS) shows three phases with high noise, about 80dB, and a variable 52-60dB background noise.

The Leq profile shows that the integration of the three high noise phases gives an equivalent level stabilizing at about 77dB at the end.

It is often necessary, or convenient, to divide the measurement time in equal duration intervals and calculate the integrated levels, as Leq, maximum and minimum levels, etc. on each interval separately instead of on the entire measurement. The multiple integration mode serves this purpose.

The **multiple integration** divides the measurement in equal intervals according to the set integration time ( $T_{int}$ ). Each single interval begins by resetting the levels and ends when the set integration time is elapsed; the integration levels sequence ends when manually interrupted by the RUN/STOP key.

The following figure shows the Leq Short profile calculated twice per second, and the integrated Leq over intervals of 20seconds during a measurement time of 1 minute in multiple mode.

The Leq Short profile is similar to that of the previous figure. The Leq Short profile shows the multiple integration mode divided the measurement time three intervals of 20 seconds, each isolating the three noise phases. Some markers point out the beginning of each interval, when the Leq was reset. Three equivalent levels at about 75dB are obtained, corresponding to each interval.

To select the integration mode select the proper parameter (MENU >> Instrument >> Measurement >> Integration Mode) as *SING* for single integration or *MULT* for multiple integration.

To perform the setting directly from the keyboard, press SELECT to choose the integration interval. When the integration interval numeric value flashes, press RIGHT to set the *multiple* integration mode or LEFT to set the *single* integration mode. When the integration mode is set on MULT, the “Tint” symbol flashes.

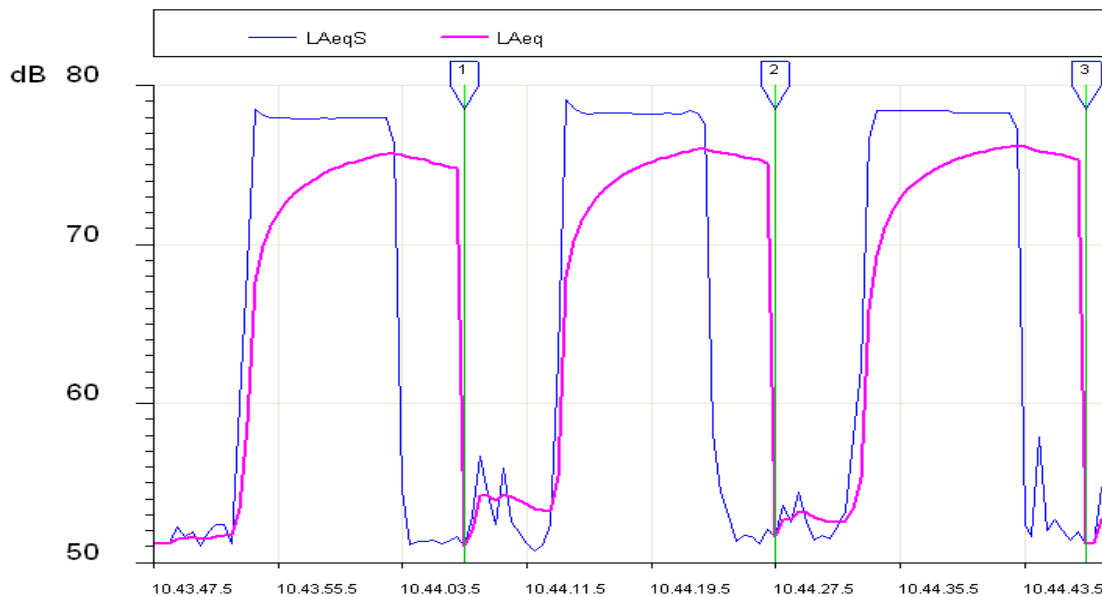

## SINGLE INTEGRATION

When the integration mode is **single**, the sound level meter resets the integrated parameters (i.e. Leq), starts measuring the instant sound levels (i.e. SPL) and calculates the integrated levels (i.e. Leq, maximum and minimum levels or statistical levels), regularly until acquisition stops.

This mode provides, at the end of the measurement session, the integrated levels over the whole acquisition period. The parameter “MENU >> Instrument >> Measurement >> Integration Interval” allows to suspend the display update, when set time is over. Now, to store displayed data press REC and hold it down *for at least 2 seconds*, then select the manual storage option. Press PRINT if you want to send displayed data to the serial output.

While display update is paused (HOLD mode), the sound level meter continues measuring and calculating the sound levels; press HOLD to let display update start again. If you do not wish to continue beyond the set integration time, press STOP to interrupt the acquisition.

When the integrating mode is **SINGLE** and the sound level continuous recording is active, the acquisition is automatically ended once the set integration time is elapsed.

The PAUSE/CONTINUE key can be used to suspend the calculation of integrated levels temporarily, while instant levels are still being measured. During a pause, and as far as the integrated levels displayed on the SLM page are concerned, you can delete the last integration seconds through the “Back-Erase Function (data exclusion)” see page. 16. The monitor function is not affected by the acquisition pauses. The continuous recording function suspends data storage during the acquisition pauses and automatically stores a marker indicating the pause duration and the possible use of the erase function.

The sound level meter has an additional timer for acquisition over time intervals (MENU >> General >> Measures >> Report). With this function it is possible to split the measurement time over programmable duration intervals from 1 second up to 1 hour; for each interval it is then possible to calculate a set of 5 integrated levels choosing from Leq, max, min levels, SEL and statistical levels. These data are not directly available on the display but can be stored activating continuous recording mode. The report levels can be evaluated directly on the sound level meter display using the “Navigator” program, selecting the Report mode for the replay.

Interval acquisition can be activated only in “SINGLE” integration mode.

**MULTIPLE INTEGRATION (REQUIRES THE “ADVANCED DATA LOGGER” OPTION)**













When the integration mode is at intervals, the sound level meter automatically makes a continuous sequence of acquisition intervals having a duration equal to the integration time set through the parameter “MENU >> Instrument >> Measurements >> Integration interval”. Each acquisition interval starts clearing the integrated levels and the “Tint” symbol on the SLM page flashes.

This integration mode, together with the Auto-Store function (MENU >> Instrument >> Recording >> Auto-Store) allows to record the SLM parameters at intervals equal to the set integration time (see “THE RECORD FUNCTION” on page 30). Automatic recording occurs at the end of each integration interval.

When the Auto-Store function is active, the *REC* symbol will flash alternating with the indicator of the sound level meter acquisition, up on the left side of display.

“MULTI” integration mode prevents the possibility to use the Report Interval parameter to record at defined time intervals and over triggered events. Statistical analysis and integrated levels are zeroed at the beginning of each integration interval.

The following table gives the different measurement and storage modes of the HD2010UC.

Integration	Auto-Store (Advanced Data Logger option)	Measurements	Continuous Recording (Advanced Data Logger option)	Single Recording
SINGLE	OFF	Press  to start. The integration ends when $t=T.Int.$ , enters in HOLD mode, and it is possible to continue by pressing HOLD or to stop with  .	Press  +  to start. Automatic stop when $t = T.Int$	Press  to record the displayed data.
	ON	Press  to start. Automatic stop when $t=T.Int.$ with recording of the SLM,.	----	----
MULTIPLE	OFF	Press  to start. The integration of the sound levels occurs according to intervals equal to $T.Int.$ The integrated levels are cleared at the beginning of every interval.	Press  +  to start. Continuous recording with LAST marker at the end of each integration period. Stop by pressing  .	Press  to record the displayed data.
	ON	Press  to start. The integration of the sound levels occurs according to intervals equal to $T.Int.$ The integrated levels are cleared at the beginning of every interval and recorded at the end.	----	----

## PRINT AND MONITOR FUNCTIONS



If you press and soon release the **PRINT** key, you can send to a PC or to a printer, via the serial interface, the screen-page displayed when pressing the key, in ASCII format. The suggested serial printer can be the HD40.1 (please refer to page 66). On the instrument display, a letter “**P**” replacing the status indicator, highlights data transfer.

If the **PRINT** key *is hold down* until the letter **M** (*Monitor* function) and the recording status indicator flash alternatively, the displayed screen will be continuously sent to the serial interface: press **PRINT** again or **STOP** to end the operation.

After activating the Monitor function, even if you press the **MODE** key, the type of screen sent to the serial interface will not change.

The **PRINT** function can also be selected starting from the **STOP** status. In this case the function will automatically activate as soon as the instrument switches into the **RUN** mode.

If the instrument gets into the **PAUSE** mode, the function will remain active, but sent data will be combined with the “**P**” symbol indicating the suspension status of the integrated parameter calculation.

The Monitor function does not interfere with data recording (which needs “advanced data logger” option) on memory and can be activated simultaneously.

A series of values is sent every 0.5s.

## THE RECORD FUNCTION

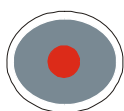

The **REC** key supervises the function of recording data on the instrument memory. Two recording modes are available: the *single (manual or automatic)* and *continuous* recording. The automatic (Auto-Store) and continuous recording modes are available with the “Advanced Data Logger” option”.

### MANUAL AND AUTOMATIC SINGLE RECORDING

When only the REC key is pressed *for at least 2 seconds*, the displayed screen will be recorded as a **single record**. When you press REC and before the instrument stores the active screen, you will be asked to confirm the recording title containing order date and number. This operation can be performed in RUN, HOLD, PAUSE and STOP modes. With the “Advanced Data Logger” option, when the single recording is activated while the instrument is in STOP mode, you will be first asked to choose between automatic and manual storage.

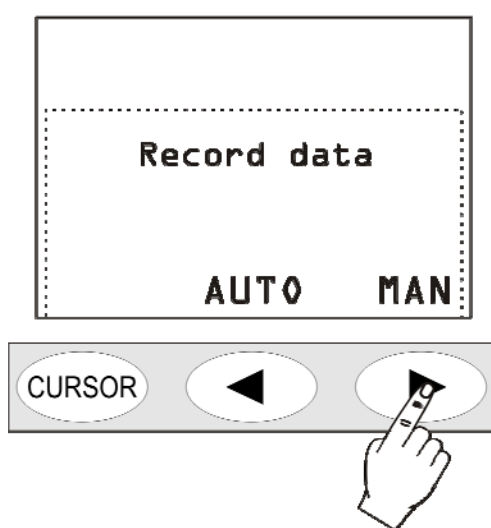

If the *manual* recording has been selected, the instrument will behave as per the above description (Single record recording).

If, on the contrary, the *automatic* recording mode “AUTO” (“Advanced Data Logger” required) has been selected, the sound level meter is set for Auto-Store mode. The parameter “MENU >> Recording >> Auto-Store” will be activated and the REC symbol blinks over the status indicator.

Press START to begin automatic recording: as soon as the measurement time reaches the set integration time, the parameters shown on the SLM screen are recorded automatically. If the integration mode is *single*, the acquisition will be stopped. If it is *multiple*, on the SLM a new integration and recording cycle will start automatically after all parameters are reset.

Press REC while the instrument is in STOP mode, to disable the Auto-Store function and jump back to the continuous integration mode.

The automatic recording can be also activated from the corresponding menu item (MENU >> Recording >> Auto-Store).

If the Auto-Store function is enabled in single integration mode, the parameters displayed on the SLM screen will be stored when the set integration time is over. Then the capture will be automatically stopped.

When the parameter “MENU >> General >> Measurement >> Integr.Mode” is set to MULT mode (the symbol “Tint” in the SLM screen starts to blink), then the acquisition is repeated over time intervals corresponding to the set integration time; each time interval is automatically pre-

ceded by the reset to zero of integrated levels (ref. to chapter “DESCRIPTION OF THE DIFFERENT INTEGRATION MODES”).

This integration mode, together with Auto-Store function, enables to record, over a time period equal to the integration time, the parameters available on the SLM mode screen. The integration time (equal to recording time period) is programmable on the SLM mode screen or, alternatively, using the specific parameter on the menu (MENU >> General >> Measurements >> Integration Interval).

## CONTINUOUS RECORDING

If the “Advanced Data Logger” option is installed and the keys REC and START/STOP/RESET are pressed *simultaneously*, the **continuous** recording of data on memory will be activated. The 3 parameters of SLM mode are stored twice a second, while the A weighted sound level with FAST constant is stored 8 times a second.

Press PAUSE to stop recording temporarily; press CONTINUE to restart it. As soon as you go back to the RUN status, a special record is stored, containing indications about the possible erase (see the “Back-Erase Function” in SLM mode on page 16) besides date and time. The HOLD key does not affect data recording.

When the continuous recording is active, if the integration mode is set to *single*, the integration time acts like a timer stopping automatically the acquisition as soon as the set time is elapsed. Integration time is programmable from SLM display or using the relative menu item (Menu >> Instrument >> Measurement >> Integration interval).

When integration mode is set to *multiple*, continuous recording do not stop when integration time elapses: a special marker (“Last”) is stored together with the last data just before the integrated levels clearing at the beginning of each integration period (see the chapter “DESCRIPTION OF THE DIFFERENT INTEGRATION MODES” on page 26). The statistical levels and also the integrated parameters displayed on the SLM screen are cleared.

## CONTINUOUS RECORDING OF REPORT AND EVENTS GROUPS

With the *Advanced Data Logger* option, by performing the measurements in single integration mode, you can also record reports and events. The parameters of the SLM and PROFILE screens are included in the **Measurement** group. Together with the Measurement group recording, you can also enable the Report and Event groups recording.

The Report and Event groups are composed of the following storable parameters:

- 5 integrated parameters
- Statistics

The Report group is recorded at programmable intervals, using the parameter MENU >> Instrument >> Measurement >> Report Time, from a minimum of 1s to a maximum of 1 hour. The 5 integrated parameters, the spectra and the statistics are automatically cleared at the beginning of every report time.

The 5 reported parameters can include:

- FAST, SLOW and IMPULSE weighted maximum and minimum levels
- Peak level
- Equivalent level
- SEL
- Preset percentile levels L1, L2, L3 and L4

The enabling of the report time is an alternative to the multiple integration mode. The report time can be set only in single integration mode.

The Event group is recorded, per each detected event (see paragraph “EVENT TRIGGER FUNCTION ” on page 24), at the end of the event itself. The 5 integrated parameters, the spectra and the statistics are automatically cleared at the beginning, and are integrated for the entire duration of the event. The 5 event parameters can include:

- FAST, SLOW and IMPULSE weighted maximum and minimum levels
- Peak level
- Equivalent level
- SEL

The event trigger feature can be activated only in single integration mode. Therefore it is not possible to enable event recording while multiple integration mode is selected.

When the Measurement group recording is activated together with the Report and Event groups recording, the Measurement group continuous recording is enabled only with the events sensed by the event trigger. This allows a lot of memory to be saved, minimizing information losses: during the events the maximum quantity of logged information occurs, while with outside sound events, the recording of the level is also carried out according to a reduced time resolution, as defined in MENU >> Instrument >> Measurement >> Report time.

Fig. 10 shows the recording flow for the Report and Event groups.

The Measurement group recording interval is equal to 2 recordings a second.

In the following example, also the Report group items are memorized with a Report time amounting to 10s.



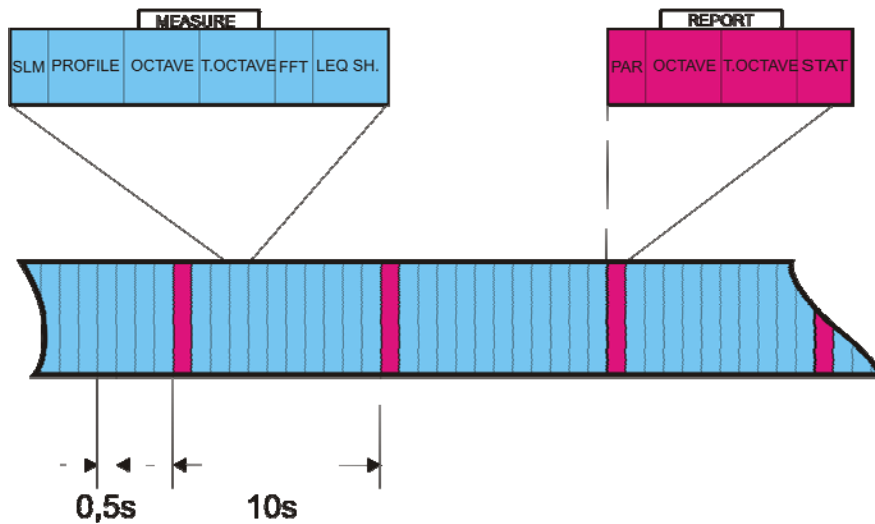

Fig. 10

When the trigger function detects an event, identified by the overcoming of the trigger threshold, or when ENTER is pressed, a time marker is recorded.

Similarly, when the end of event conditions are sensed, as identified by the deactivation threshold being reached, or by the external TRGIN signal, or when ENTER is pressed, and after the set stop delay has elapsed, another time marker is recorded. After the time marker, when the event is closed, the record containing the Event group information is logged.

When the event trigger uses the Profile view sound level as source (Menu >> Trigger >> Source: LEV), the event data are recorded only when the trigger threshold (Menu >> Trigger >> Trigger Threshold) exceeds the minimum duration time (Menu >> Trigger >> Minimum Duration). The following figure shows the recording flow for the Measurement, Report and Event groups. The Measurement group recording is enable only during the event; outside the events, only Reports are recorded. In the following example a report is recorded every 10s.

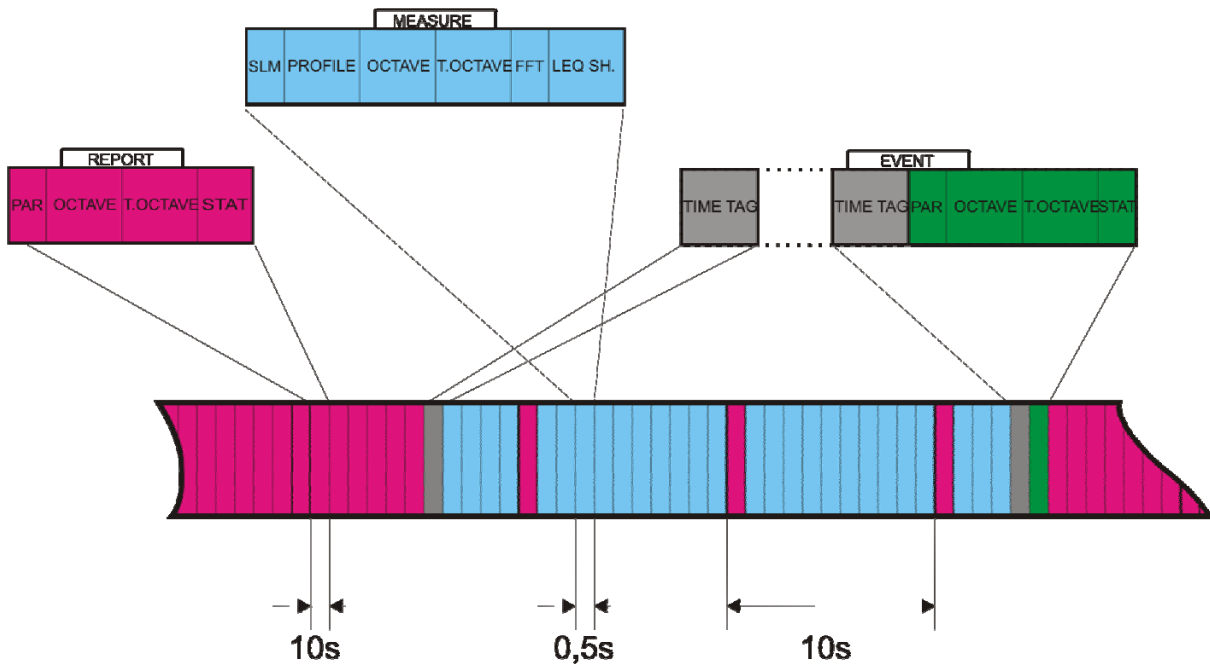

Fig. 11 - Recording flow for the Measurement, Report and Event groups

When the trigger threshold is exceeded for a shorter period than the minimum duration time, the record containing the Event group information is not logged.

## Delayed acquisition timer

A timer is available to enable data acquisition according to a programmable delay of up to 99 hours. To perform an acquisition with delayed start, the recording parameters need to be set first and then the **delayed acquisition timer** programmed in the parameter Menu >> Sequencer >> Timer.

After programming the sound level meter, you only need to press the **REC** and **RUN** keys together (as if starting a logged measurement): confirm with the “YES” key. The instrument switches into stand-by and turns off (see. Fig. 12).

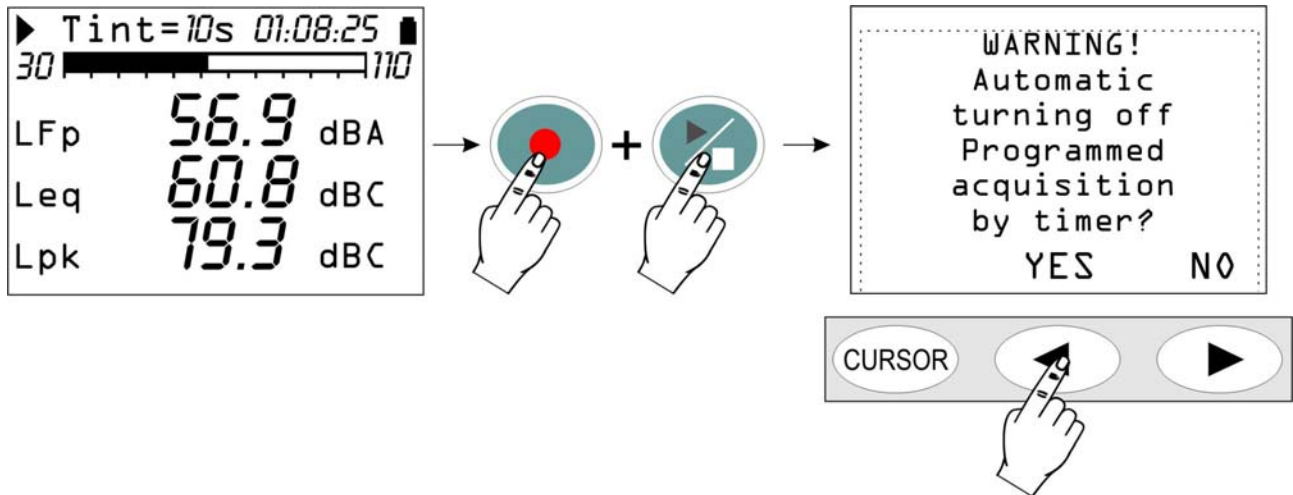

Fig. 12 - Delayed acquisition timer warning screen

The instrument will turn back about one minute before the set delay, to allow execution of the warm up time before starting the automatic acquisition. During this waiting minute, the “TIMER” message blinks, showing the automatic acquisition feature has been activated.

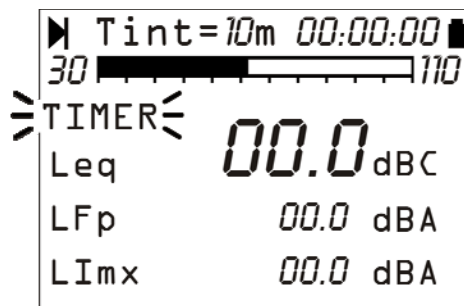
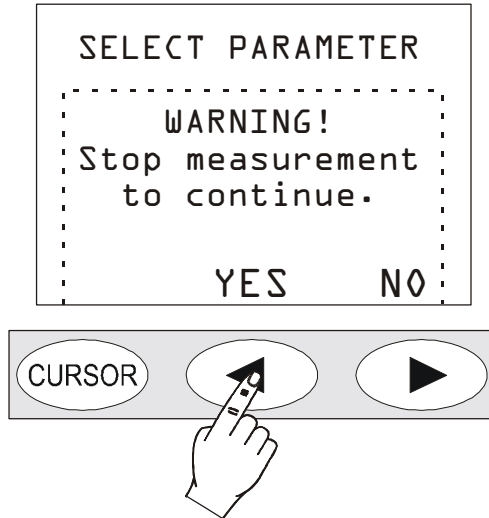

Fig. 13 - Waiting for the timer start

The acquisition will end when the **set integration time (Tint)** has elapsed and the instrument will automatically turn off after disabling the timer.

## DESCRIPTION OF THE MENU FUNCTIONS

The menu collects all of the parameters through which the instrument functions are set. The menu can be accessed even when the instrument is measuring, but parameters can be modified only if the instrument is in STOP mode. If this is not the case, a message will invite you to stop the current measurement: "WARNING! Stop measurement to continue".



Press YES, and you will be allowed to change the selected parameter.

Some of the parameters listed in the menu can also be modified directly from the measurement displays: see the chapter concerning the different display modes (from page 13).

The menu is nest-structured, that is, it is organised in menus and submenus. To select a menu item, use the UP and DOWN arrows until the selected item flashes. When the parameter next to a menu item does not flash, it means that the item cannot be changed.

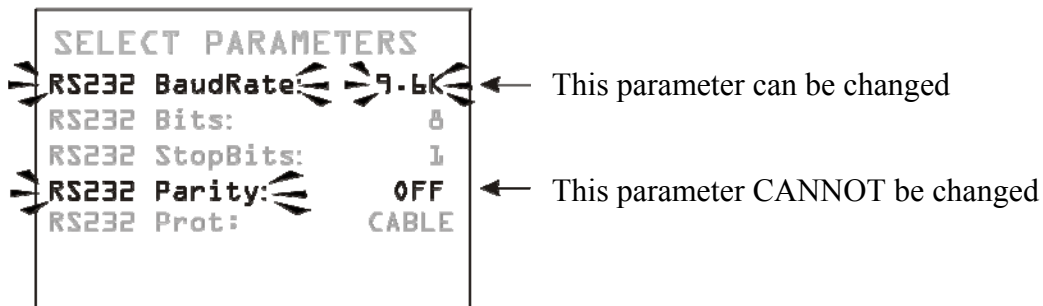

Press SELECT to access the selected submenu or to modify the selected parameter.

Use the UP and DOWN arrows to edit the flashing selected parameter: press ENTER to confirm the new value, press MENU to cancel the input changes.

Press MENU to exit a menu and return to the upper level until you get the measurement display again.

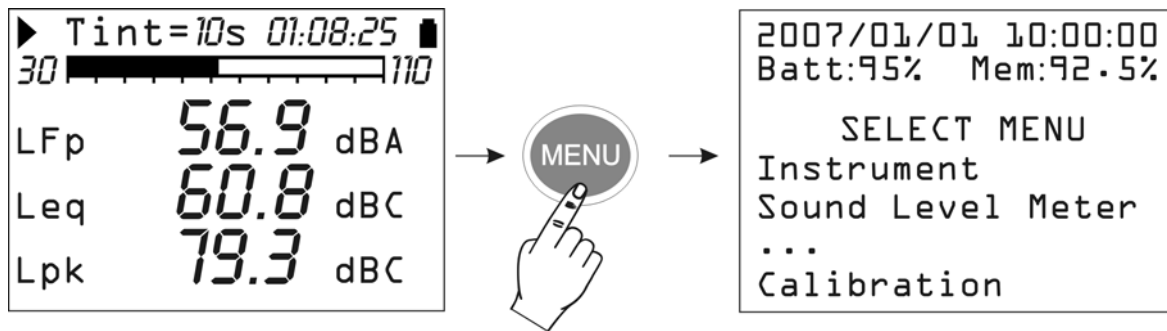

When you access the menus, current date and time are displayed, as well as the battery charge level and the available memory.

If you are in a submenu, the "SELECT MENU" item becomes "SELECT SUB-MENU".

The dots at the end of a list mean that there are other items following the visible ones: press the DOWN arrow to display them.

## INSTRUMENT

The Instrument menu includes all data relevant to the instrument identification, as well as some general parameters of the instrument itself, input and output settings and measurement global parameters. It consists of four submenus, as described below.

### IDENTIFICATION

It includes the information that identifies the instrument and the microphone. These are all items that cannot be changed by the user.

- **Instrument:** instrument name.
- **Serial N.:** instrument serial number.
- **Version:** current firmware version loaded.
- **Microphone:** supplied Free Filed microphone model is UC52.
- **Mic. S.N.:** microphone serial number.
- **Mic. Response:** type of microphone response. FF stands for Free Field, DF for Diffused Field).
- **Class IEC61672:** Class of tolerance according to IEC61672:2002
- **Memory:** memory available on the instrument. The standard is 2Mbyte.
- **Options:** firmware options.
- **Ext. range:** always OFF.

### SYSTEM

It allows configuring some system parameters.

- **Time:** current time.
- **Date:** current date expressed as year/month/day.
- **Display contrast:** allows adjusting the display contrast. When the ambient temperature changes, the display contrast slightly changes: it can be adjusted entering a higher value to increase the contrast or a lower one to decrease it. The value can be set between 3 (minimum) and 9 (maximum).

- **Auto-Power-Off:** the instrument is provided with the auto-power-off function that automatically switches it off after 5 minutes the instrument is in STOP mode and no key has been pressed. Before switching off, the instrument will make a series of beep: press any key to prevent the instrument shutting off. The function is active if this menu item is "ON". If you set Auto-Power-Off = OFF, the instrument will not automatically shut off. **In this case the battery symbol will flash even if batteries are fully charged.**

## INPUT/OUTPUT

Submenu for the choice of parameters relevant to the instrument inputs and outputs.

- **Baud Rate:** **Baud Rate:** this parameter and the next ones define the properties of the serial connection. Selectable baud rate values go from a minimum of 300 to a maximum of 230400 baud. The higher is the value, the faster is the connection; therefore, **when possible**, it is suggested to select the highest available value to speed up data transfer as much as possible. If the instrument is connected to a printer with RS232 serial input or with a serial/parallel converter, the value to be set is the one provided by the printer manufacturer.  
**WARNING: When you use the serial interface, the communication between instrument and computer (or printer with serial input) works only if the instrument and PC (or device) baud rates are the same. Take care of this note when using data transfer programs requiring a manual configuration of the serial port parameters, such as, i.e. HyperTerminal. The NoiseStudio program, combined with the HD2010UC automatically sets the serial port, so that no action by the operator is required.**
- **RS232 Bits:** (*non-modifiable parameter*) number of bits of which transferred data are made up, the value is 8.
- **RS232 Stop Bits:** (*non-modifiable parameter*) stop bit, the value is 2.
- **RS232 Parity:** (*non-modifiable parameter*) parity bit, the value is: none (OFF).
- **Serial Device:** identifies the device connected to the serial port.  
The connection possibilities are:
  - **PRINTER:** connection to a printer with RS232 input
  - **RS232:** connection to a PC equipped with RS232 port (physical)
  - **MODEM:** connection to a modem with RS232 input RS232 (see Connection to a modem on page 66)
  - **USB:** connection to a PC by USB port (see "CONNECTION TO A PC WITH USB INTERFACE" on page 68)
  - **MC:** connection to optional module HD2010MC for SD memory card recording (see paragraph on page 71)

## MEASUREMENTS

The *Measurement* item includes the acquisition general parameters.

- **Input Gain:** with Input Gain = 0 the measuring range upper limit equals 140dB, and as much as the input gain increases the maximum measurable level decreases correspondingly (see page 74). Select the proper gain according to the level of sound to be.
- **Integration interval:** Once this time has been reached, the instrument automatically switches to HOLD, interrupting display update. It can be set from a minimum of 1s to a maximum of 99 hours. When continuous recording is activated, the integration time acts like a timer for data acquisition, stopping automatically the measurement when the time is elapsed. If set to 0s, the timer is disabled and the integration becomes continuous.
- **Report Time:** report parameters are integrated over intervals corresponding to the set time. At the beginning of every interval report parameters are automatically cleared. Report time can be set to: 1, 2, 5, 10, 20 and 30 seconds, 1, 2, 5, 10, 20, 30 minutes and 1 hour. A re-

port time can be set only for the single integration mode (see parameter “Integration mode”). This parameter needs the “Advanced Data Logger” option”.

- **Max Back-Erase:** maximum erase interval of data recorded in SLM mode. The available values are: 5s, 10s, 30s and 60s: the erase interval is settable with 1s, 2s, 5s or 10s steps, respectively. See description on page.16.
- **Exchange Rate:** is used together with "DOSE Threshold" and "DOSE Criterion" in DOSE calculation. It represents the variation of the sound pressure level corresponding to the double or the half of the exposure maximum time with the same Criterion Level (indicated as “DOSE Criterion”). Its value can be equal to 3dB, 4dB or 5dB.
- **DOSE Threshold:** it is the noise level below which the DOSE is not increased. The value can be set in the 0dB÷140dB interval, with 1dB steps.
- **DOSE Criterion:** it is the noise level providing a DOSE equal to 100% after an 8 hour exposure. The value can be set in the 60dB÷140dB interval, with 1dB steps.
- **Overload Level:** according to the selected input gain, the instrument provides two measuring ranges: the former with a 130dB upper limit, the latter with a 140dB one. If the sound level exceeds the 131dB and 141dB limits, respectively, the display will highlight the overload indication ( $\Delta$  and  $\Lambda$ ). The indication can be activated also at lower input levels, programming this parameter from 20dB, minimum, to 200dB maximum, with 1dB steps. The shown level defines the overload threshold when the input gain corresponds to 0dB (Input Gain). The overload threshold automatically scales with the input gain.
- **Integration mode:** Two integration modes are available: the former is single (SING) and the latter is multiple (MULT). For the description of the two modes see chapter “DESCRIPTION OF THE DIFFERENT INTEGRATION MODES”. The multiple integration mode requires an Integration interval different from zero be set, and disables Report Time and Event Trigger.
- **Lev. 1, 2, 3 and 4 Percentile:** in the statistical analysis of sound events,  $L_N$  percentile levels are defined as the levels of noise exceeded for N time percentage throughout the whole measurement interval. For example,  $L_1$  represents the sound level exceeded by 1% of the measurement time. These items define 4 percentile levels selectable between 1% and 99% with 1% steps. The corresponding variables are shown in the SLM view as L1, L2, L3 and L4, combined with the respective percentage.

## SOUND LEVEL METER

The Sound Level Meter menu features all parameters relevant to the SLM display mode. These items can be changed directly from the respective display as described in "Selecting Parameters " on page16

The first three items of the menu, from Par. 1 to Par. 3, define the three measuring parameters and the respective frequency weightings relative to the SLM display mode.

Press RIGHT to change the time weighting of measuring parameters, when selected. When the time weighting flashes, use the UP and DOWN arrows to change it.

The list of available parameters is shown on appendix A1. HD2010UC Measuring Parameters on page 98

## STATISTICAL ANALYZER

The *Statistical Analyzer* menu (needs the “Advanced Data Logger” option) collects the specific parameters related to the statistical graphs display modes. These items can be changed directly in their screens.

- **Param.:** the parameter used for selected statistical calculations:  $L_{Fp}$ ,  $L_{eq}$  and  $L_{pk}$  with A, C and Z (only C and Z for  $L_{pk}$ ) weightings. The sampling frequency is equal to 8 samples/s (only 2 samples/s for  $L_{pk}$ ).

- **Class width:** statistical analysis is performed by 0.5dB classes.
- **Display Stat.:** enables (ON) or disables (OFF) displaying of the distribution of probabilities and percentile levels graph.

## TRIGGER

The *Trigger* menu (needs the “Advanced Data Logger” option) collects the specific parameters related to the event trigger.

- **Source:** the trigger source can be chosen among: profile view sound level (LEV), ENTER key (MAN),.
- **Trigger Threshold:** the trigger threshold on the profile view sound level (LEV); it can be programmed with 1dB steps.
- **Trigger Threshold:** the trigger threshold on the profile view sound level (LEV); it can be programmed with 1dB steps.
- **Bottom Threshold:** the deactivation threshold, different than the trigger one, on the profile view sound level (LEV); it can be programmed with 1dB steps.
- **Trigger Polarity:** it is possible to choose increasing (POS) or decreasing (NEG) levels for the trigger on the profile view sound level (LEV). For the increasing levels trigger, the Trigger Threshold will be higher than the Bottom Threshold, for the decreasing levels trigger the Trigger Threshold will be lower than the Bottom Threshold.
- **Minimum Duration:** a duration filter is available to eliminate false triggers. It is activated upon detection of the event, only if the trigger condition persists for a number of seconds at least equal to this parameter. It is used only if the Source parameter is set to LEV.
- **Stop Delay:** when the trigger conditions are not present anymore, the event ends after a number of second equal to this parameter has elapsed.
- **Printing:** printing of a warning string (TAG) can be enabled through the serial interface for each event.

## RECORDING

In the *Recording* menu (“Advanced Data Logger” required) the parameters relating to the logging of the measured data can be found. It collects the settings concerning the recording of the sound levels measured in each screen, the report, and event parameters. If no parameter is enabled for recording (all OFF), the instrument warns of the impossibility to record.

When the “Advanced Data Logger” option is enabled, the recording parameters are divided in three sub-menus: Measurement, Report, and Event. Without this option only the Measurement sub-menu can be accessed. For details please see chapters “THE RECORD FUNCTION” on page 30 and “CONTINUOUS RECORDING OF REPORT AND EVENTS GROUPS” on page 32.

## MEASUREMENTS

In this menu continuous recording is defined, (requires the “Advanced Data Logger” option as described in “THE RECORD FUNCTION” on page 30).

- **Auto-Store:** activates the auto-recording mode of SLM screens, as described in “THE RECORD FUNCTION” on page 30. By enabling this feature report time and event trigger are disabled.
- **SLM + PROFILE:** activates the continuous recording of parameters of the SLM screen and PROFILE.

If the *Auto-Store* function is activated, SLM screens will be automatically stored when the set integration time is over. When this function is activated with the multiple integration mode, recording is performed automatically according to the set integration time. Integration time is programmable from SLM display or using the relative menu item (Menu >> Instrument >> Measurement >> Integration interval). The enabling of the recording mode is indicated by a flashing REC over the status indicator. Recording is started by pressing RUN. To disable the Auto-Store function press the REC key briefly.

## REPORT

In this menu the recording of the reports is defined, (it requires the “Advanced Data Logger” option). Each item can be enabled separately, as with the measurement recording. In order to avoid occupying memory space uselessly, we recommend to enable only the needed items and set the others to OFF. The integration interval (recording time) of the reports is programmable using the relative menu item (Menu >> Instrument >> Measurement >> Report Time).

- **Par.1 – Par.5:** define five integrated parameters, with relevant frequency weightings.
- **Parameters:** enables recording of the 5 parameters Par.1 – Par.5, defined previously.
- **Statistics:** activates the recording of the statistics.

## EVENT

In this menu (it requires the “Advanced Data Logger” option) the recording of the event reports is defined, as described in the paragraph THE RECORD FUNCTION”. Each item can be enabled separately, as with the measurement recording. In order to avoid occupying memory space uselessly, we recommend to enable only the needed items and set the others to OFF.

- **Par. 1 Par. 5:** define five integrated event parameters, with relevant frequency weightings.
- **Parameters:** enables recording of the 5 parameters Par.1 – Par.5, defined previously.
- **Statistics:** activates the recording of the event statistics

## CALIBRATION

- **Calibration Level:** Sound level of the reference sound source used for the sound level meter calibration. Allowed values vary from 90.0dB to 130.0dB with a 0.1dB resolution.
- **Microphone Response:** allows selecting the type of frequency response of the microphone according to the sound field. The standard setting for the standard microphone (UC52) is “Free Field” (FF), since it has a frequency response optimized for the “free field”. Set the parameter to “Random Incidence” (RI) to activate the correction for random incidence sound. This setting is necessary to carry out measurements according to ANSI standards. The random incidence correction is not available on the HD2010UC Class 2.  
When HD WME microphone rain protection is used, for aircraft noise (0° incidence) measurements the FF setting must be used while RI setting must be used for community noise (90° incidence) measurements (e.g. road traffic noise).
- **Wind Shield Correction:** Allows correcting the frequency response of the sound level meter when the HD SAV windshield provided with the sound level meter, or the HD WME outdoor shield, is used. When this parameter is set to SAV or WME, the sound level meter frequency response is corrected for the windshield or the outdoor shield presence, respectively. The random incidence correction is not available on the HD2010UC Class 2. For additional details on applied microphone correction, please see UC2 microphone manual.



## SEQUENCER

The *Sequencer* menu needs the “Advanced Data Logger” option.

- **Timer:** programmable acquisition delay in seconds, minutes, or hours up to a maximum of 99 hours (see paragraph “*Delayed acquisition timer*” on page 34).

## PROGRAMS

The item PROGRAMS (**PROG** key) includes the following functions:

- Navigator: to display stored data (“Advance Data Logger” required),
- Electric and Acoustic Calibration
- Diagnostic Check: diagnostic test of instrument,
- Data copy on MC: this program allows to copy measurements stored on sound level meter’s flash memory onto an external Secure Digital memory card (please refer to related chapter on page 73).

Each program is here below described in details.

### NAVIGATOR

This program, available with the “Advanced Data Logger” option, allows to access the data stored on the instrument, display and print them, with no need to download them to a PC. It works both with single session data and with multiple ones. Press: **PROG** >> Memory Navigator >> **SELECT** to access it. The following screen will appear:

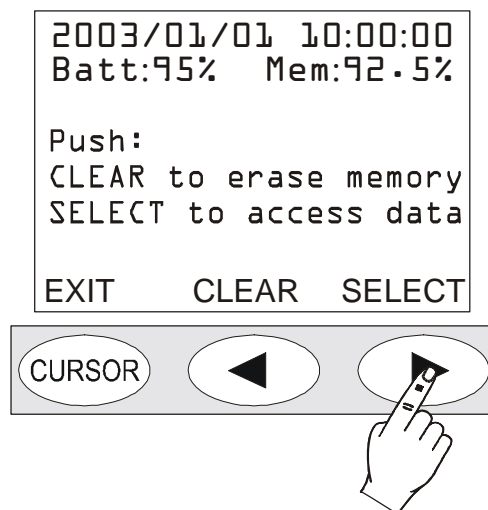

If you press **CLEAR**, the content of the instrument memory will be cleared. The user will be asked a confirmation before clearing.

Press **SEARCH** to access the first session of stored data on memory.

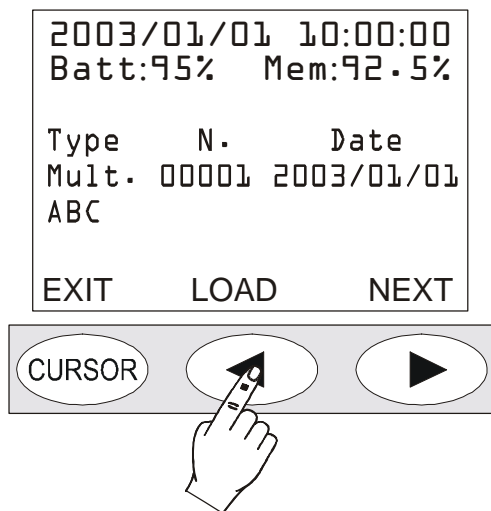

The following data are indicated for each file: the type (single, multiple or automatic), the progressive number given by the instrument upon logging and the date. Press NEXT to jump to the next file, press LOAD to download the current file.

If you press LOAD, the instrument goes back to standard display and the STOP and battery symbols alternate with the R (Replay) and P (Program) letters respectively).

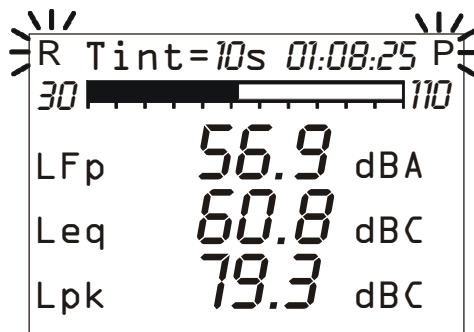

Four types of files are recorded:

- Sing. Single screen in manual recording
- Auto SLM screen in continuous recording (with “Advanced Data Logger” option”)
- Mult. Multiple screens in continuous recording (with “Advanced Data Logger” option”)

*File type: “Sing”*

Relative data are loaded and displayed automatically pressing the LOAD key

*File type “Auto”*

Press START to see the data session: the screens of the measurement session will be displayed in the acquisition order. During the replay use the PAUSE/CONTINUE key to stop and restart the replay, or press STOP to finish. At the end, the instrument will position on STOP. A single screen page can be sent at any moment to the serial interface.

While the replay is in pause, press START if you want to display the next data. If, while in pause, the START key is hold down, the replay will be forwarded fast.

*File type “Mult.”*

Press START to see the data session: if no reports and/or events were recorded, the measurement session screens will be displayed, as for the “Auto” files. If, in addition to measurements, reports and/or events were also recorded (the “Advanced Data Logger” option is required), an intermediate page is displayed allowing the display of measures, reports, or events to be chosen (see chapter CONTINUOUS RECORDING OF REPORT AND EVENTS GROUPS on page 32).

When replaying reports and events, in the SLM screen, reports and events parameters will be displayed respectively. When events are displayed they are shown one by one, including automatically a pause between the event and the next one. During pause, pressing the START key, allows to load the data of the following event and PAUSE to restart replay.

The replay of measurements associated with event recording, automatically enables the pauses at the beginning and end of each event trigger. These pauses correspond to the time markers recorded when the trigger spots the event and at the end when saving the relevant data.

If the recording contains measurements, reports, and events, the measurements are not registered continuously but only in coincidence of the sound events detected (see EVENT TRIGGER FUNCTION on page 24).

Disabling of measurements outside the events, in combination with event and report recording, allows two different recording speeds to be maintained, slow and fast, associated with reports and measurements respectively. The maximum recording resolution is used only during events by enabling the Measurement group parameters recording (see CONTINUOUS RECORDING OF REPORT AND EVENTS GROUPS on page 32) while for the other acquisition elements only the Report group parameters are recorded, using a lower time resolution.

When the simultaneous recording of measurements, reports, and events is enabled, and the event trigger uses the Profile view sound level as source (Menu >> Trigger >> Source: LEV), the measurement recording begins as soon as the sound level exceeds the trigger threshold (Menu >> Trigger >> Trigger Threshold) without waiting for the minimum duration time (Menu >> Trigger >> Minimum Duration). The measurement recording ends as soon as the stop delay has elapsed (Menu >> Trigger >> Stop Delay) after the level exceeded the deactivation threshold (Menu >> Trigger >> Bottom Threshold).

After having examined a file size, press **PROG** to jump back to the Memory Navigator menu: press **LOAD** to reload the current session, **NEXT** to display the properties of the next session or **EXIT** to quit.

At the end of the list of stored files, “End of Dump” will be displayed. Press **REWIND** to go back to the first file of the list.

## CALIBRATION

Calibration is periodically carried out to ensure the validity of measurements performed by the sound level meter and to control possible long-term drifts of the measuring chain microphone-preamplifier-instrument. To ensure that measurements performed by the sound level meter are made in conditions of stability, the letter “W” will flash over the indicator of the instrument status throughout the whole period needed to stabilize the microphone polarization, signalling the “warm-up” period necessary every time the instrument is switched on.

The HD2010UC sound level meter stores all calibration typical parameters with respective date and time in a reserved area. The calibration types can be:

- *Acoustic calibration* by means of a 1kHz sound level generator, like HD 9101
- *Electric calibration* (Capacitive Transducer Calibration) with the possibility to measure the frequency response of the whole measurement chain, microphone included, using the built-in signal generator.

Calibration is necessary every time that the calibrator level, measured by the sound level meter, deviates from the nominal value for more than 0.5dB.

**The acoustic calibration includes the capacitive transducer one** and, before carrying it out, it is suggested to ensure that the environment where you are operating is suitable: no sudden sounds, no vibrations on the surface where the instrument is placed, instrument thermal stability. **The electric calibration allows a quick inspection of the electric parameters of microphone and instrument.** The calibration procedure includes the inspection of the microphone polarization.

Calibration programs are in the “PROGRAMS” menu, accessible through the PROG key.

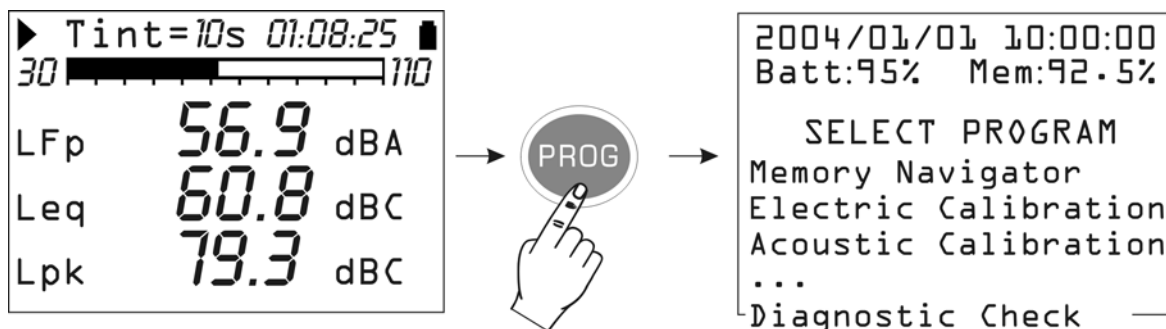

Use the UP and DOWN arrows to select the calibration to be carried out:

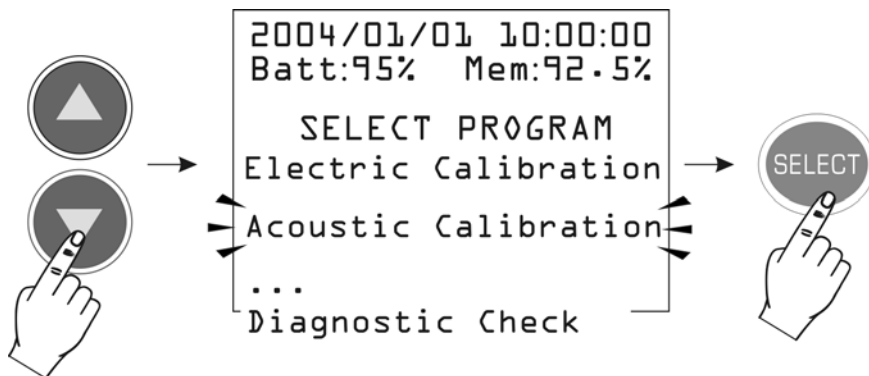
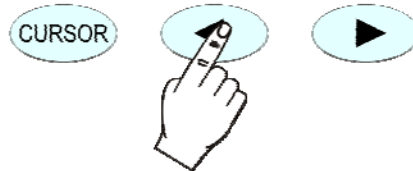
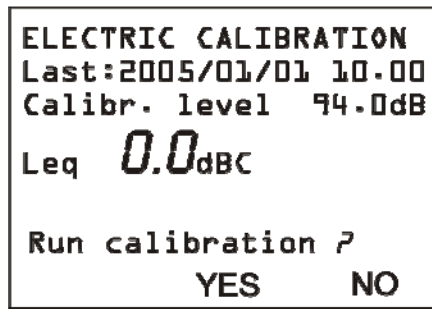

Fig. 14

when you press SELECT, the calibration display will appear.



The screen shows date and time of the last calibration and the calibrator sound level according to the configuration of the respective parameter (MENU >> Calibration >> Calibr. Level). Answering positively to the request to continue, the selected calibration program will start.

Calibration procedures are carried out in automatic mode and the operator is guided by the on-screen instructions.

The calibration result is displayed when the procedure is over and you can choose whether to confirm it or not. **If confirmed, the new calibration will be stored.**

In order to grant the highest measuring accuracy when the wind shield mounted, select “Wind Shield Correction” from the CALIBRATION menu to apply a correction to the sound level meter frequency response and compensate the effects of the HD SAV shield provided with the instrument. All measurement parameters with wideband frequency weightings are thus automatically adjusted.

In the 2010UC sound level meter, besides the windshield correction, the adjustment for the acoustic field can be activated too.

With the standard microphone (UC52), which has a frequency response optimized for the “Free Field”, no correction is applied when the correction is set on “Free Field”. When you set the correction on “Random Incidence” (RI), the correction for random incidence sound will be activated. This setting is necessary to perform measurements according to ANSI standards (see the parameter of the menu: CALIBRATION >> Microphone Response).

The HD2010UC sound level meter is suitable for measurements on site in a temperature range between  $-10^{\circ}\text{C}$  to  $+50^{\circ}\text{C}$ , in a static pressure range between **65 kPa** and **108 kPa** and in a relative humidity range between 25% and 90%. The microphone itself has defined drift coefficients of acoustic sensitivity with temperature and static pressure that imply a measurable drift of the Microphone-preamplifier-instrument chain, even though within the limits specified for class 1 according to IEC 61672:2002 new standard.

## PERIODIC CALIBRATION

The periodic calibration of the HD2010UC sound level meter is needed to ensure the traceability to the laboratory standards and is carried out in accredited laboratories, for example, SIT, etc.

The HD2010UC sound level meter is calibrated at Delta Ohm Acoustic Laboratory (SIT laboratory N. 124) before being supplied to the user.

“Factory” calibration, which is always made on new instruments and at every periodic calibration (every 2 years, at least), includes the measurements of the acoustic response in pressure of the microphone-preamplifier-instrument chain, stored on the sound level meter non-volatile memory, together with the microphone acoustic sensitivity. Right after the measurement of the acoustic response in pressure, also the Capacity Transducer Calibration (sound level meter electrical calibration including the microphone) is carried out, to be used as a reference for the calibrations made by the user.

Every time a periodic calibration of the sound level meter is carried out at the factory, calibration constants are stored as a reference for following comparisons. The factory calibration can be loaded onto the instrument to make a comparison or to correct a wrong calibration. This procedure will also load the instrument default parameters so that, if there are any data stored on memory, these will be deleted.

Follow this procedure to proceed with this operation:

- Download any data stored on memory
- Ensure that logging is on STOP mode
- Remove the external power supply, if connected
- Remove one of the batteries: the instrument will obviously switch off (this operation assures that all the sound level meter internal circuits are discharged)
- Press and hold down the ENTER key while inserting the missing battery
- The instrument will automatically turn on and will show a warning message indicating that factory parameters have been loaded
- Press CONTINUE to confirm and make an acoustic calibration to store calibration constants. If this operation is not carried out, or in case the acoustic calibration should give a negative result, upon the next power on, factory calibration data will be replaced by those stored in the last successful calibration.

Electrical signals supplied by a generator connected to the HD2010UC preamplifier via a capacitive adapter (replacing the microphone) can be used for periodic tests. The capacitive adapter (specific for the model of microphone supplied with the instrument) is an accessory that can be supplied by Delta Ohm S.r.l. Other capacitive adapters can be used, provided that the device equivalent capacity is included between 15 pF and 33 pF.

During calibration procedures, before performing electrical or acoustical test, it's necessary to disable sound level meter spectral corrections

- Menu >> Calibration >> Microphone Resp. Correction >> FF
- Menu >> Calibration >> Shield >> SAV

The frequency response check is made using an acoustic coupler under pressure field conditions (for example using a B&K4226 multifrequency calibrator) . For additional information on corrections to be applied to frequency response, see specific UC52 microphone user manual.

## *Microphone capsule maintenance*

In order to avoid permanent deterioration of frequency response and subsequently a decay of the specifications until the unit goes out of type 1 tolerances., it is necessary to prevent that dust particles and dirt accumulate on the microphone membrane. **It is suggested to calibrate the unit every year at an accredited calibration laboratory.**

Avoid to use the unit in the presence of steam containing oil, conductive or corrosive substances. Also humidity condensation on the membrane must be avoided, as it modifies acoustic response, causes corrosion and contributes to the formation of residues difficult to remove.

When HD WME weather protection is connected and sound level meter turned ON, power supply and preamplifier heating avoid condensation of humidity on the microphone membrane. When the sound level meter is OFF, heating of the preamplifier is disabled and it's therefore possible that condensation is formed on the microphone. We advise to put the HD WME unit in a dry environment when not in use.



## ELECTRIC CALIBRATION

The electric calibration, using the partition of charge injected into the microphone preamplifier in “charge amplifier” configuration (Capacitive Transducer Calibration), even if it **cannot completely replace the acoustic calibration**, provides however a useful means to keep under control the instrument drifts, microphone included. The figure on the right shows the diagram of the CTC technique consisting in sending an electrical signal to the preamplifier through a high stability capacitor, so that the output signal does not depend only on amplification, but also on the microphone capacity. Many of the microphone malfunctions reflect in a capacity drift identifiable by means of this calibration technique. The electric calibration uses as a reference the result of the last acoustic calibration, and according to it corrects any possible drift of the instrument. The electric calibration adjusts the acoustic response of the microphone-sound level meter chain, both for wideband channels, and for those with a constant percentage bandwidth. In case of continuous instrument drifts, it is suggested to carry out an acoustic calibration to verify that there are no other problems both in instrument and microphone.

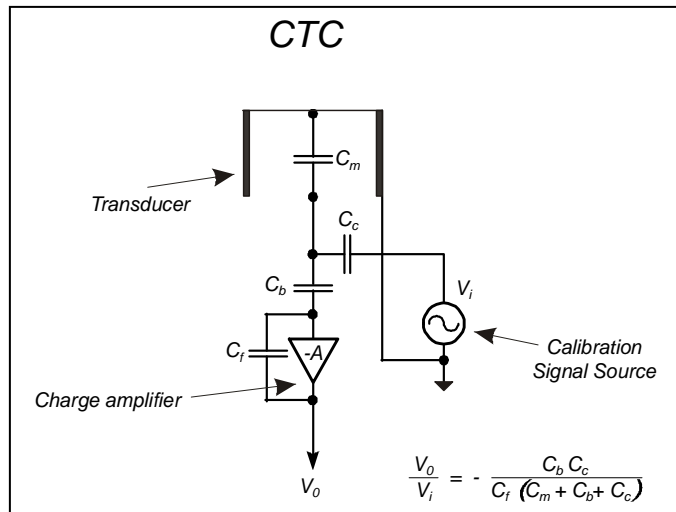

## Operating Procedure

Switch on the sound level meter, if it is the case, press STOP to finish the measurement in progress and make the following procedure:

1. Press PROG and use the DOWN arrow to select "Electric Calibration".
2. Press SELECT to start the function.
3. The inner signal generator will be turned on and the measured output signal will be compared with the one detected in the last acoustic calibration.

The value that appears on the display (51.3 dBC in the example below), before starting calibration, is the valued measured by the microphone upon pressure of the PROG key, and is not relate to the calibration in progress.

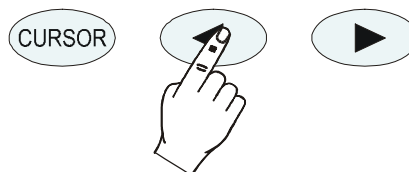
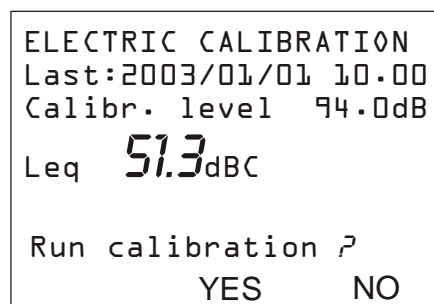

4. Press YES to continue and NO to quit.

5. If you press YES, the calibration is run: wait till the procedure will be over.
6. At the end, the calibration result will be shown and you will be asked to confirm a new calibration:

```
ELECTRIC CALIBRATION
Last:2003/01/01 10.00
Calibr. level 94.0dB
  ΔLeq -0.1 dBC
Confirm calibration ?
      YES   NO
```

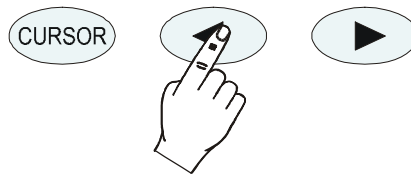

7. Press YES (keypad LEFT key) to confirm or NO (keypad RIGHT key) to refuse the calibration just finished. At the end, the instrument will switch to the SLM display, in STOP mode.

The stabilization on a value far from the reference one, indicated by a  $\Delta Leq$  higher than some tenths, means that one of the components of the microphone-preamplifier-instrument chain was affected by a considerable drift and if this difference exceeds the maximum limit admissible by the instrument, calibration will fail. In this case, refer to “Troubleshooting” (page 90), and if necessary contact our service department.

## ACOUSTIC CALIBRATION

In order to keep the acoustic sensitivity of the microphone-sound level meter chain steady over the time and in the different using conditions, a reference sound source is used, which generates a pure tone at a reference frequency with a given pressure level, stable over the time. For this purpose acoustic calibrator class 1 or class 2 conforming to IEC 60942 and compatible with the microphone capsule UC52 are used.

For the HD2010UC models are available Class 1 HD2020 and HD9101 calibrators while HD9102 model is available for Class 2 versions.

The control that the reference sound level by the acoustic calibrator is correctly measured by the sound level meter (it is normally acceptable that the difference between the sound level measured by the sound level meter and the nominal level of the calibrator be lower than 0.5dB) has to be carried out before and after a series of measurements, to ensure that measured values are correct. When the difference between the sound calibrator level measured with the sound level meter and the nominal value exceeds 0.5dB, it is necessary to perform an additional acoustic calibration.

**Warning: to prevent damaging the sound level meter, it is important, during the calibration procedure, to follow carefully the on-screen instructions and the indications provided by this manual.**

## Operating Procedure

Switch on the sound level meter, if necessary, press STOP to finish the measurement on progress, and perform the following procedure. The program will automatically control that the warm-up time, indicated by a flashing W, is over.

1. Press PROG and, with the help of the DOWN arrow, select "Acoustic calibration". Press SELECT to start calibration:

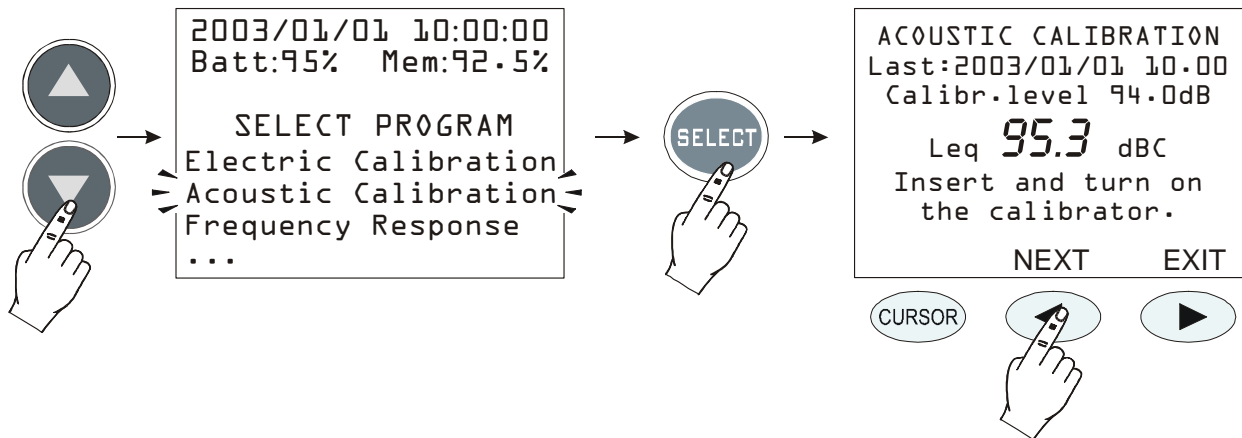

2. The first screen shows the date of the last calibration (Date:...) and, in the line below, the calibrator sound level to be used in the calibration in progress (this value can be modified, before starting the calibration program, by selecting "Calibration Level" from the MENU: see page.40). Insert the microphone in the calibrator hole and switch it on.
3. Select the sound level indicated on the sound level meter display (94dB is the nominal value), then press NEXT to continue.
4. Now, the instrument measures the sound level applied and waits for it to become steady: the measured level will be displayed. The indication "Waiting for level stabilization..." will be viewed..."

When the sound level has stabilized, the measured value is compared to the reference one and if the difference is acceptable, it is logged. In this case, the message "Turn off the Calibrator" will appear. Press NEXT to continue.

```

ACOUSTIC CALIBRATION
Last:2003/01/01 10.00
Calibr.level 94.0dB
Leq  94.0 dBC
Turn off the calibra-
tor.
NEXT

```

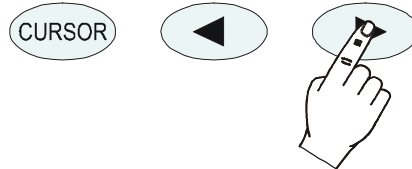

5. After the acoustic calibration, the **electric calibration** will be automatically started. This stage of the procedure generates the reference data for the following electrical calibrations.

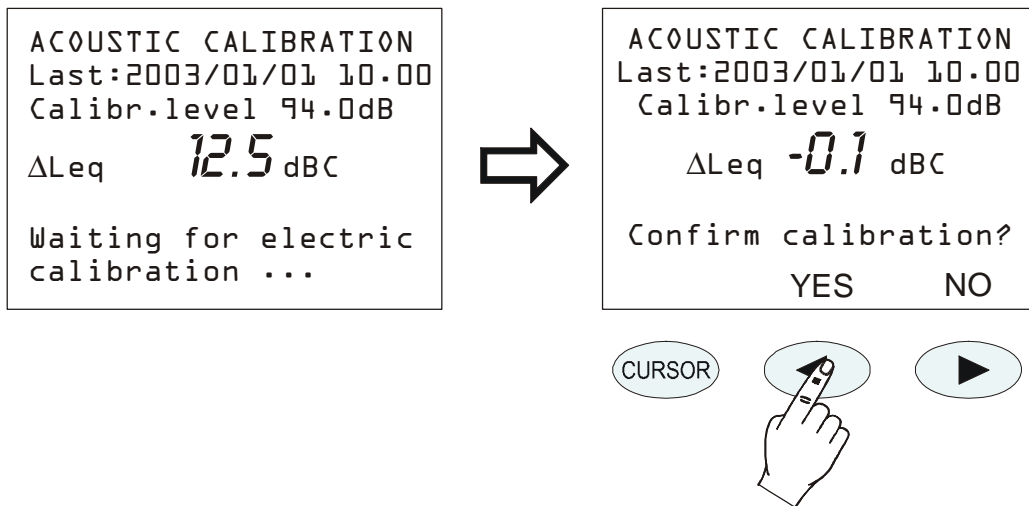

6. At the end, if the values of the electrical calibration are acceptable, press YES to confirm the new calibration (LEFT arrow of the keypad); at this point, press NO if you want to cancel the whole calibration (RIGHT arrow of the keypad).
7. Finally, the microphone polarization check is carried out. Wait until "Take out the preamplifier from the calibrator" appears".

```
ACOUSTIC CALIBRATION
Last:2003/01/01 10.00
Calibr.level 94.0dB
ΔLeq    -0.1 dBC
Checking microphone
polarization ...
```



```
ACOUSTIC CALIBRATION
Last:2003/01/01 10.00
Calibr.level 94.0dB
Leq     96.1 dBC
Take off the
calibrator
EXIT
```



8. Take out the preamplifier from the calibrator and press EXIT.
9. The procedure is over.

If calibration constants were incompatible with a correct working of the instrument, calibration would fail and the message “Calibration failed! Consult the manual” would appear. In this case, refer to “Troubleshooting” (page 90), and if necessary contact our service department.

## MICROPHONE REPLACEMENT

The 2010UC sound level meter is calibrated in the factory in conjunction with the microphone. If the microphone capsule sensitivity deviates too much from factory calibration, the sound level meter blocks acoustic calibrations and reports the microphone as damaged.

The acoustic calibration can therefore fail even if the capsule is replaced or repaired, or if using a capsule with different characteristics from the one supplied.

If you wish to replace the microphone capsule it is necessary to use wizard implemented in Noise Studio under the menu >> Instrument management >> new microphone. The procedure requests the use of a certified acoustic calibrator; it is described in detail in Noise Studio's online Help under "Options >> New Microphone".

## DIAGNOSTIC CHECK

The diagnostic test is a program that verifies a series of electrical critical parameters. The following are checked: supply voltages, microphone polarization and sensitivity, and the type of pre-amplifier. At the end of the procedure, should it fail, a table will be shown with the results of the inspection. If necessary, refer to "Troubleshooting" (page 90), and if needed contact our service department.

## FIRMWARE UPGRADE

The firmware, that is the program managing all of the instrument functions, can be upgraded by transferring the file from a PC to the HD2010UC through the serial/USB port. In this way, all the instrument functions can be updated. Up-dating files are available at the authorized dealers.

To make the update, you need to use "firmware update" function of the NoiseStudio; Noise Studio must be installed on your PC.

See "NoiseStudio Handbook" online help for details.

## OPTIONS UPGRADE

HD2010UC options (**HD2010.O0** "Memory Module" and **HD2010.O2** "Advanced Data Logger" can be purchased and installed after the purchase of the basic kit.

"Advance Data Logger" option, if purchased, can be activated directly by the user using Noise Studio software package. Alternatively it's possible to send the instrument to Delta Ohm S.r.l. technical service for upgrade.

To activate the new option it can be used the "upgrade instrument options" function of Noise Studio software using the activation code supplied after purchase. Please see online manual of Noise Studio for details.

## BATTERY SYMBOL AND BATTERY REPLACEMENT

The battery symbol  in the upper right corner of the display constantly provides the charge status of the instrument batteries. The more the batteries discharge, the more the symbol gets "empty" ...



... when the battery voltage reaches the minimum value for a correct operation, the symbol flashes. At this point, only 5 minutes of autonomy are left and batteries should be replaced as soon as possible.

**If the instrument is still used, the battery voltage will decrease still further and the instrument cannot ensure anymore a correct measurement; data recording is automatically interrupted, as well as data logging and the instrument goes into STOP mode. Under a given level, the instrument will automatically shut off. Data stored on memory will remain. The instrument cannot be switched on again until the battery level remains low.**

The battery charge level is available on the menu main screen and on the program screen, expressed as a percentage value. Press MENU or PROG to view it. When the level is indicated by 0%, 5 minutes of autonomy are left.

The battery symbol changes into a plug when the instrument is connected to an external power supply.

**Note:** the battery symbol also flashes when the auto power-off is disabled (AutoPowerOFF = OFF).

To replace the battery, switch the instrument off, then unscrew anticlockwise the two screws of the cover of the battery space. After replacing batteries (4 1.5V alkaline batteries - type AA), close again the cover and fasten the two screws clockwise. Check date and time. If this operation takes less than two minutes, no clock adjustment should be needed.

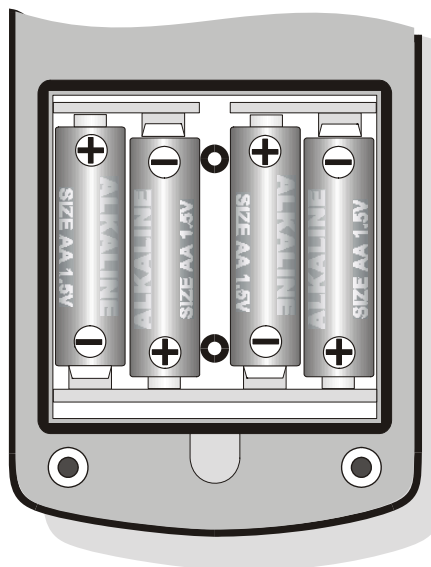

As an alternative to alkaline batteries, you can use rechargeable batteries. Batteries with lower capacity usually show greater impedance, causing a worsening of the electrical noise generated by the sound level meter, with repercussions on the measurement dynamic. Therefore zinc-carbon and rechargeable NiCd batteries are not recommended.

## WARNING ABOUT THE USE OF BATTERIES

- Batteries should be removed when the instrument is not used for an extended time.
- Flat batteries must be replaced immediately.
- Avoid loss of liquid from batteries.
- Use waterproof and good-quality batteries, if possible alkaline.
- If the instrument does not turn on after battery replacement:
  - Remove one of the batteries
  - Wait at least 5 minutes for the sound level meter internal circuits to discharge
  - Put the new battery in. If the batteries are charged the instrument should turn on automatically.

## INSTRUMENT STORAGE

- Temperature: -25...+70°C.
- Humidity: less than 90% R.H. no condensation.
- To be avoided:
  1. High humidity storage.
  2. Direct sun irradiation over the instrument.
  3. High temperature source near the instrument.
  4. Presence of strong vibrations.
  5. Steam, salt and/or corrosive environments.

The instrument case is in ABS plastics material and the protection belt in rubber: do not use any solvent for cleaning.



## SERIAL INTERFACE

The instrument is provided with a versatile serial interface with double protocol: RS232C and USB. The interface settings depend on the item “MENU >> General >> Input/Output >> Serial Disp.”:

- PRINTER: connection with RS232 interface of the portable serial printer.
- MODEM: connection with RS232 interface to a modem.
- RS232: connection with RS232 interface to a PC equipped with COM type physical port.
- USB: connection with USB interface to a PC where the VCOM driver is installed.

The RS232 setting allows to connect the sound level meter to a COM type physical port of a PC. This connection does not need any particular program to work as it is allowed by the common architecture of PC equipped with RS232 (COM) port. The maximum speed of data transfer is up to 115200 baud.

In the last few years, in order to meet the needs of the new audio and video peripherals, the USB standard has been used for information serial transfer. Recently many PC manufacturers do not offer the COM type ports any longer, which are usually replaced by the USB type ports. There is a 4 wire connection, two wires for information transfer, other two wires for the power supply. As far as the data transfer is concerned, the main differences with respect to the RS232 interface RS232 are:

- The transfer occurs in simplex mode, i.e. it's impossible to carry out simultaneously a transfer in both the directions
- The data are transferred as package size
- The transfer time is defined by only one of the two units (the master)
- The transfer speed is fix at 1.5Mbit/s, 12Mbit/s or 480Mbit/s according to the USB standard and the kind of connected device.

The two devices connected through the USB interface are identified as master and slave. The master supplies power to the slave and decide the sense and the transfer time scheduling.

The USB interface of sound level meter is a sort of slave and then it has to be connected to a USB master able to supply with the necessary power and to manage the communication.

On the HD2010UC standard kit it is included a serial connection cable; the user can choose between code HD2110RS for PC with COM ports or code HD2110USB for PC with USB ports.

The **HD2110/RS** cable is a *null-modem* cable with 9-way sub D female connector. The HD2110/USB cable is fitted with an USB connector type A. On request, the connection cable for modem or printer (DCE) with a 25-way sub D male connector (code **HD2110/CSM**) or with a 9-way sub D male connector (code **HD2110/CSP**) can be supplied.

When the item “MENU >> Instrument >> Input/Output >> Serial Device” is set on “PRINTER”, “MODEM” or “RS232”, the following signals are connected to the 8 pin male connector type M12 available on the instrument:

Pin	Direction	Signal	Description
1	Input	CTS	Clear to send
2	Output	DTE	DTE ready
3	Input	DCE - CD	DCE ready – Carrier detect
4	Output	VDD	Power supply 3.3V
5	Input	RD	Receiving data channel
6	Output	RTS	Request to send
7	Output	TD	Transmitting data channel
8	-	GND	Reference ground

The following signals are connected to the 9 pin sub D male connector of the HD2110/RS cable:

Pin	Direction	Signal	Description
1	DCE >> HD2010UC	DCE - CD	DCE ready – Carrier detect
2	DCE >> HD2010UC	RD	Receiving data channel
3	HD2010UC >> DCE	TD	Transmitting data channel
4	HD2010UC >> DCE	DTE	DTE ready
5	-	GND	Reference ground
7	HD2010UC >> DCE	RTS	Request to send
8	DCE >> HD2010UC	CTS	Clear to send
9	HD2010UC >> DCE	VDD	Power supply 3.3V

When the item “MENU >> General >> Input/Output >> Serial Device” is set on “USB”, the following signals are connected to the 8 pin male connector type M12 available on the instrument:

Pin	Direction	Signal	Description
2	I/O	DP	Datum +
4	I/O	DM	Datum -
6	Input	VBUS	Power supply 5V
8	-	GND	Reference ground

**While the sound level meter is connected to an active terminal (DCE active) via the RS232 interface, the auto power off is disabled and the instrument cannot be switched off.** If the instrument is off, the connection to an active terminal (DCE active) will turn it on.

Standard parameters of the instrument serial transmission are:

- Baud rate     baud 38400
- Parity        None
- N. bit         8
- Stop bit      1
- Protocol      Hardware.

Data transmission speed can be changed through the "*Baud rate*" parameter inside the menu - (MENU >> Instrument >> Input/Output >> Baud Rate – see page 37). The available baud rates are: 230400, 115200, 57600, 38400, 19200, 9600, 4800, 2400, 1200, 600, 300. The other transmission parameters are fixed.

The 2010UC is provided with a complete set of commands to be sent via the serial port of a PC.

## COMMUNICATION PROTOCOL

The command consists of ASCII strings with a variable length, ending in CR-LF.

The instrument provides always a response, after a command has been received; if the command is not accepted, the response string is always NAK-CR-LF. It is possible to disable the response, when it is not expressly requested by the command, modifying the VERBOSE setup parameter (see the SET paragraph).

Commands are divided into 5 groups, as shown in the following table.

Group	N. of Commands	Description
SET	60	SETUP: parameter configuration
KEY	21	KEY: keyboard simulation
STT	4	STATUS: instrument status
DMP	6	DUMP: memory dump

Each group contains a given number of commands. Each command is identified by a specific string. The generic syntax of a command is the following:

< group>:<command>:<value >:CR-LF

Ex.: “SET:INPUT\_GAIN:10\r\n”

sets the INPUT\_GAIN parameter to 10dB (see SET paragraph).

Only capital characters are acknowledged. Each token can be shortened at the minimum number of characters that univocally identify it. The example can be shortened as follows:

“SET:INP:10\r\n”

Here are the possible command formats.

A3 - SET:INTEGRATION\_TIME:<{SS,MM,HH}>:< value >CRLF

A4 - SET:TIME:<hh>:<mm>CRLF

A5 - SET:DATE:<aaa>:<mm>:<gg>CRLF

A6 - SET:x\_SLM\_PARAMETER:< Parameter abbreviation>:<parameter attribute >CRLF

A8 - SET:<COMAND>:< value >CRLF

A10 - SET:<COMAND>:?CRLF

C1 - KEY:<COMAND>CRLF

C2 - KEY:<COMAND>:< value >CRLF

D1 - STT:<COMAND>:< OPTION >CRLF

E1 - DMP:<COMAND>CRLF

If you enter “?” properly in the string, you can get either a help for the compilation of the desired command or the current status of the instrument configuration parameters. Here are the formats of the commands that use the “?” character “?”.

0	?CRLF	Provides the list of the groups of commands
A9	SET:?CRLF	Provides the command list of the SET group
A10	SET:<COMMAND>:?CRLF	Provides the current status of the specified command
C3	KEY:?CRLF	Provides the command list of the KEY group
D2	STT:?CRLF	Provides the command list of the STT group
D3	STT:<COMMAND>:?CRLF	Provides the current status of the specified command
E2	DMP:?CRLF	Provides the command list of the DMP group

## SET GROUP (SETUP)

The following table shows the list of the commands of the SET group (SETUP).

Command	Format	Description
INSTR_MODEL	A10	Instrument model - UNMODIFIABLE
INSTR_NUMBER	A10	Instrument serial number - UNMODIFIABLE
INSTR_VERSION	A10	Instrument version - UNMODIFIABLE
MIC_MODEL	A10	Microphone model – UNMODIFIABLE
MIC_NUMBER	A10	Microphone serial number – UNMODIFIABLE
MIC_TYPE	A10	Type of microphone – UNMODIFIABLE
CLASS	A10	Class of tolerance – UNMODIFIABLE
MEM_SIZE	A10	Memory size – UNMODIFIABLE
OPTIONS	A10	Firmware options – UNMODIFIABLE
TIME	A4	Time (hh:mm)
DATE	A5	Data (aaaa/mm/gg)
DISP_CONTRAST	A8	Display contrast (3÷9, default: 5)
AUTO_POWEROFF	A8	Instrument auto-power-off (ON/OFF, default: ON)
BAUD_RATE	A8	RS232 baud rate
DEVICE	A8	Serial device
INPUT_GAIN	A8	Input gain
INTEGRATION_TIME	A3	Integration time in s, m (1÷59) od h (1÷99)
REPORT_TIME	A8	Report Time
ERASE_TIME	A8	Erase interval
EXCHANGE_RATE	A8	Exchange rate in dB (3÷5)
DOSE_THRESHOLD	A8	Dose threshold in dB (0÷140)
CRITERION_LEVEL	A8	Criterion level in dB (60÷140)
VERBOSE	A8	Acknowledge (ON/OFF, default:ON). Always ON upon power on.
OVERLOAD_LEVEL	A8	Overload level in dB (20÷200)
INT_MODE	A8	Integration Mode
1 PERC LEVEL	A8	Percentile level 1 in % (1 ÷ 99, default: 1)
2 PERC LEVEL	A8	Percentile level 2 in % (1 ÷ 99, default: 10)
3 PERC LEVEL	A8	Percentile level 3 in % (1 ÷ 99, default: 50)
4 PERC LEVEL	A8	Percentile level 4 in % (1 ÷ 99, default: 90)
1 SLM PARAMETER	A6	SLM parameter 1 (see parameter list)
2 SLM PARAMETER	A6	SLM parameter 2 (see parameter list)
3 SLM PARAMETER	A6	SLM parameter 3 (see parameter list)
STAT PARAMETER	A6	Parameter for statistical analysis
EVN_TRIGGER	A8	Event trigger source
EVN_ON_LEVEL	A8	Trigger activation level dB (10 ÷ 140, default: 90)
EVN_OFF_LEVEL	A8	Trigger deactivation level dB (10 ÷ 140, default: 60)
EVN_POLARITY	A8	Trigger level polarity (POS/NEG)
EVN_ON_TIME	A8	Trigger activation delay in seconds from 0 to 10
EVN_OFF_TIME	A8	Trigger deactivation delay in seconds from 0 to 255
EVN_PRINT	A8	Enabling event trigger printing
AUTO_STORE	A8	Enabling Auto-Store function (ON/OFF, default: OFF)
SLM+PROF_DLOGGE R	A8	Continuous recording of SLM and PROFILE parameters (ON/OFF, default: ON)
1 REP PARAMETER	A6	REPORT parameter 1 (see parameter list)
2 REP PARAMETER	A6	REPORT parameter 2 (see parameter list)

Command	Format	Description
3 REP PARAMETER	A6	REPORT parameter 3 (see parameter list)
4 REP PARAMETER	A6	REPORT parameter 4 (see parameter list)
5 REP PARAMETER	A6	REPORT parameter 5 (see parameter list)
REP PARAMETERS	A8	Recording of REPORT parameters 1-5 (ON/OFF, default: OFF)
REP STATISTICS	A8	Statistical recording (ON/OFF, default: OFF)
1 EVN PARAMETER	A6	EVENT parameter 1 (see parameter list)
2 EVN PARAMETER	A6	EVENT parameter 2 (see parameter list)
3 EVN PARAMETER	A6	EVENT parameter 3 (see parameter list)
4 EVN PARAMETER	A6	EVENT parameter 4 (see parameter list)
5 EVN PARAMETER	A6	EVENT parameter 5 (see parameter list)
EVN PARAMETERS	A8	Recording of EVENT parameters 1-5 (ON/OFF, default: OFF)
EVN STATISTICS	A8	Statistical recording (ON/OFF, default: OFF)
CAL LEVEL	A8	Acoustic calibrator level in dB (90.0 ÷ 130.0, default: 94.0)
MIC CORR	A8	Acoustic range correction
WND SHL CORR	A10	Wind-shield correction (ON/OFF, default: OFF)
SEQ TIMER	A3	Acquisition delay in s, m (1÷59) or h (1÷99)

The value that some parameters can take is listed in the following table. The default value is in bold print.

Parameter	Value
BAUD_RATE	300
	600
	1.2k
	2.4k
	4.8k
	<b>9.6k</b>
	19.2k
	38.4k
	57.6k
	115.2k
	230.4k
DEVICE	<b>RS232</b>
	MODEM
	USB
	PRINTER
INPUT_GAIN	0
	<b>10</b>
	20
	30
	40
ERASE_TIME	<b>5s</b>
	10s
	30s
	60s
INT_MODE	<b>SING</b>
	MULT
REPORT_TIME	<b>1s</b>
	2s
	5s

Parameter	Value
	10s
	20s
	30s
	1m
	2m
	5m
	10m
	20m
	30m
	1h
	EVN_TRIGGER
LEV	
MAN	
MIC_CORR	<b>FF</b>
	RI
WND_SHL_CORR	<b>OFF</b>
	SAV
	WME
EVN_PRINT	<b>OFF</b>
	TAG

The parameters that can be displayed in SLM mode are selectable among the following ones:

Parameter	Attribute	Description
Lpk	Z or C	Instantaneous peak level, Z or C weighted
Lpkmx	Z or C	Peak maximum level
LeqS	Z, C or A	Short equivalent level, Z, C or A weighted
Leq	Z, C or A	Equivalent level
LFp	Z, C or A	FAST sound pressure level
LSp	Z, C or A	SLOW sound pressure level
LIp	Z, C or A	IMPULSE sound pressure level
LFmx	Z, C or A	FAST maximum sound pressure level
LSmx	Z, C or A	SLOW maximum sound pressure level
LImx	Z, C or A	IMPULSE maximum sound pressure level
LFmn	Z, C or A	FAST minimum sound pressure level
LSmn	Z, C or A	SLOW minimum sound pressure level
LImn	Z, C or A	IMPULSE minimum sound pressure level
LeqI	A	Equivalent sound pressure level with Impulse time constant
LE	A	A weighted exposure level (SEL)
Lep,d	A	Daily personal exposure level, A weighted (EEC/86/188)
Dose	A	A weighted dose
Dose,d	A	A weighted daily dose
L1	A	Percentile level (calculated on FAST pressure level, A weighted)
L2	A	Percentile level
L3	A	Percentile level
L4	A	Percentile level
OL	-	Time percentage in which an overload has occurred

The attribute of parameters that can be displayed in SLM mode indicates the respective frequency weighting.

## KEY GROUP

The following table shows the command list of the KEY group.

Command	Format	Description
LEFT	C1	LEFT key
MENU	C1	MENU key
PRINT	C1	PRINT key
PROG	C1	PROG key
PAUSE	C1	PAUSE key
RUN	C1	RUN key
SELECT	C1	SELECT key
UP	C1	UP key
MODE	C1	MODE key
RIGHT	C1	RIGHT key
ENTER	C1	ENTER key
DOWN	C1	DOWN key
HOLD	C1	HOLD key
CURSOR	C1	CURSOR key
CLEFT	C1	CURSOR LEFT key
CRIGHT	C1	CURSOR RIGHT key
SER_MON	C1	Simulates pressure of the PRINT key for over 2 sec
STORE	C1	Simulates pressure of the REC key for over 2 sec
DATA_LOG	C1	REC+RUN key
PRN_VAL	C1	PRINT key without printing the heading
EXEC	C2	Program execution

## GROUP (STATUS)

The following table shows the command list of the STT group (STATUS).

Command	Description
ACQUISITION	Acquisition control
DISPLAY	Display management
MONITOR	Monitor function via RS232
RECORDER	Recording management

The STT:ACQUISITION commands are provided in the following table

Command	Format	Description
HOLD	D1	Interrupts display update
UPDATE	D1	Restarts display update
PAUSE	D1	Measurement in pause
RUN	D1	Starts measurements
STOP	D1	Ends measurements
CLEAR	D1	Clears measured levels
CONTINUE	D1	Restarts measuring
ERASE	D1	Erases the last x seconds of measurements
RECORD	D1	Starts and records measurements

The STT:ACQUISITION:? command provides information on the acquisition status as shown in the following example.

```
STT:ACQ:?
STT:ACQUISITION:STOP
BATTERY: 32%
MEMORY: 95.4%
DUMP TIME:00:00:01
LAST CALIBRATION: 2003/07/31 08:37
```

The STT:DISPLAY commands are listed in the table below.

Command	Format	Description
SLM	D1	Displays 5 selectable parameters in numeric format
PROFILE	D1	Displays the time profile of a selectable parameter
PROB_DISTR.	D1	Displays the level distribution of probabilities
CUMUL_DISTR.	D1	Displays the percentile levels graph

The STT:DISPLAY:? command provides information relevant to the sound level meter actual display as shown in this example.

```
STT:DIS:?
STT:DISPLAY:Mode:PROFILE
```

The following table lists the STT:MONITOR commands.

Command	Format	Description
ON	D1	Starts the Monitor function
OFF	D1	Ends the Monitor function
MEASUREMENT	D1	Monitor
SLM	D1	Monitor by 3 parameters
PROFILE	D1	Monitor by single parameter
REPORT	D1	Monitor of the reports
EVENT	D1	Monitor of the events



The following table lists the STT:RECORDER commands.

Command	Format	Description
ON	D1	Starts the Record function
OFF	D1	Terminates the Record function
AUTO	D1	Enables the Auto-Store function

STT:MONITOR:? and STT:RECORDER:? commands provide information on the monitor and recording status as shown in the following example.

```
STT:REC:?
STT:RECORDER:Measurement:SLM:OFF
```

## DMP GROUP (DUMP)

The table below features the list of the DMP group commands (DUMP).

Comando	Formato	Descrizione
ON	E1	Starts memory dump
OFF	E1	Ends memory dump
NEXT_RECORD	E1	Requires the transmission of the next record
RECORD	E1	Requires the transmission of the current record
CLEAR	E1	Clears memory

Data download sequence is:

- DMP:ON\r\n  
The heading ending in the string “MEMORY DUMP\r\n” is printed if there are any data on memory
- DMP:RECORD\r\n  
Prints the previous record in binary format
- DMP:NEXT\_RECORD\r\n  
Prints the current record in binary format. If this is the last record, it prints the string “END OF DUMP\r\n”
- DMP:CLEAR\r\n (optional)  
Clears memory
- DMP:OFF\r\n  
Ends data dump

Data dump can be interrupted through the sequences:

- DMP:OFF\r\n  
Ends data dump

## CONNECTION TO A MODEM

A modem connection allows a remote control of the HD2010UC sound level meter. The optional Noise Studio software module NS4 “Monitor” for Windows 98/ME/2000/Xp/Vista operating systems, can fully manage the sound level meter not only via a simple RS232 or USB serial connection, but also, via the telephone line by means of two modems. While the modem that connects the PC to the telephone line must not meet any particular requirement, but being Hayes© compatible, the modem connected to the HD2010UC sound level meter has to be configurable by the sound level meter itself and shall not interfere with improper messages during the delicate data transmission phase from the sound level meter to the PC. Delta Ohm S.r.l. suggests three types of modems to be used:

- Multitech MT2834ZDX
- Digicom SNM49
- Digicom Botticelli

**The connection with these modems has been tested. Other modems might be used but, due to the great variety available on the market, we cannot provide service for the connection to modems other than those listed here.**

The modem connected to the HD2010UC sound level meter must be configured before being used for data transmission. The configuration is carried out automatically by the sound level meter itself, according to the following steps.

1. Connect the modem to the HD2010UC by means of the **HD2110/CSM** special cable with M12 connector.
2. Connect the modem to the telephone line and the power supply.
3. Switch on the modem.
4. Switch on the HD2010UC sound level meter.
5. Set the baud rate at 38400 baud at least via the parameter: MENU >> Instrument >> Input/Output >> RS232 Baud Rate.
6. Select MODEM as serial connection through the parameter: MENU >> Instrument >> Input/Output >> Serial Device.

The instrument automatically gets into the modem configuration mode. The successful configuration will be confirmed by the message “Modem Configured.” Should the configuration fail, the sound level meter will automatically switch to PC mode and the message “Configuration failed!” will be displayed.

When the modem is configured, it is possible to make the remote connection running **NoiseStudio >> Monitor** program. Possible under voltages on the modem do not create problems as the configuration is memorized and automatically loaded on turning it on.

The table shows the HD2110/CSM cable connections:

M12 connector (female 8-pole)	DB25 serial connector (male)
1	5
2	20
3	8
4	22
5	3
6	4
7	2
8	7

## Connectors - Front/External view

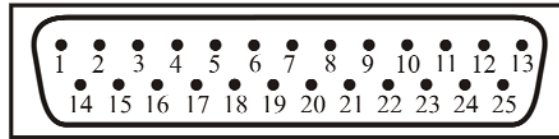

**DB25**

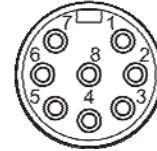

**M12**

### CONNECTION TO A PRINTER

The HD2010UC sound level meter can print the levels displayed in a format compatible with a portable 24 column printer, such as the HD40.1.

**Printer and sound level meter must be configured properly.**

#### Sound level meter configuration

1. Set the parameter MENU >> Instrument >> Input/Output >> RS232 Baud Rate to: 38.4k
2. Set the parameter MENU >> Instrument >> Input/Output >> Serial Device to: PRINTER.

#### Printer configuration

1. The printer Baud Rate **must be the same** of the sound level meter (38400 baud).
2. Data bits: 8.
3. Parity: None
4. Stop bits: 1.
5. Handshaking: Xon/Xoff
6. Auto feed: Enabled.



Connect the HD2010UC sound level meter to the printer by means of the special **HD2110/RS** cable.

Follow the instructions in the documentation supplied with the printer.

## CONNECTION TO A PC WITH USB INTERFACE

The 2010UC sound level meter fitted with USB interface can be connected to a PC's USB port by using the HD2110/USB cable.

The USB port connection requires the previous installation of a driver contained in the Noise Studio software. **Before connecting the USB cable to the PC, install the NoiseStudio software.**

With Windows 7 operating system it's necessary to boot the PC taking care to disable the request for "driver signature", as explained in the USB driver installation guide (included in the installation CD Rom of Noise Studio).

*Proceed as follows:*

1. Set the instrument menu item "MENU >> Instrument >> Input/Output >> Serial Device" to "USB". Confirm and exit from the menu".
2. **Do not connect the instrument to USB port until requested from the wizard**
3. Insert **Noise Studio** installation CD Rom and wait for AutoPlay window to appear. For Windows Vista and Windows 7 operating systems it's shown the window below; select "auto-run.exe execution" (see "note 1" in the next paragraph)

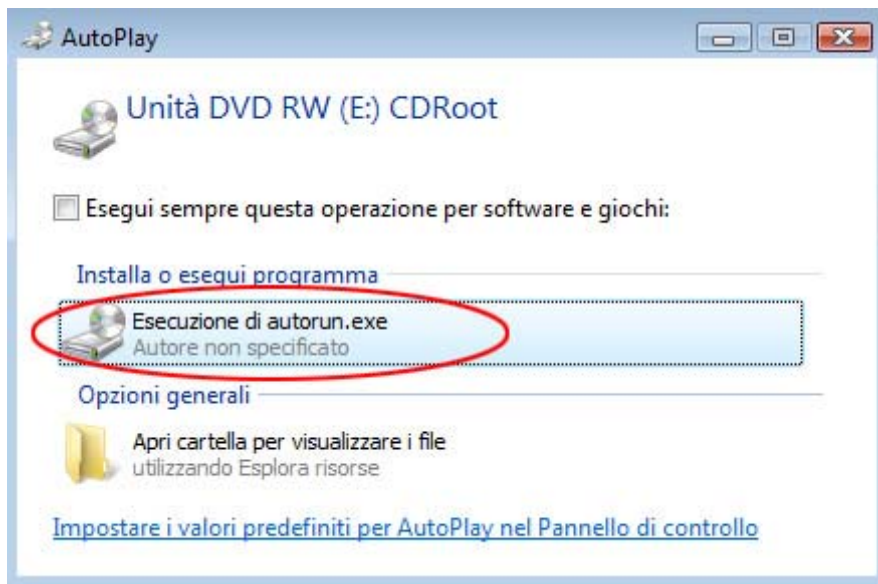

4. The starting screen of Noise Studio will be opened: if the operating system prevents software to start, please see "note 1" in the next paragraph.
5. From starting window of Noise Studio click on "USB drive installation" to start the driver installation procedure.
6. The program checks the operating system version and copies related drivers in a temporary folder.
7. At the end a message appears asking to plug the sound level meter connection cable to PC USB port: press OK and close **Noise Studio** software pressing EXIT key.
8. **Connect the sound level meter to USB port and turn it ON:** when Windows recognise the instrument, it appears a message that *a new device has been detected*.
9. Wait some seconds until the message "new hardware is installed and ready to work" appears.
10. Driver installation procedure is ended: whenever the instrument will be connected it will be automatically recognized.

## NOTE FOR INSTALLATION

### Note 1: for Windows Vista and Windows 7 operating systems.

1. For software installation is requested Administrator permission
2. If the operating system prevents the software to open, boot the PC as **administrator**, insert installation CDROM and, when the following window appears, select “Open folder to view files”

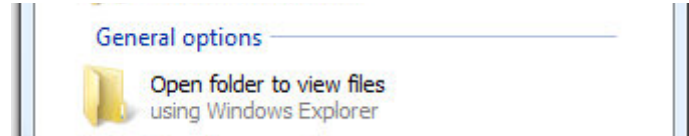

3. In the following screen, click with right mouse key on file “Autorun” and select “Execute as administrator”:
4. Continue from point 5 of previous paragraph.

**Note 2:** if the sound level meter has been connected to USB port **before USB driver installation**, in Windows 2000 and XP operating systems it appears the window “*new hardware installation*”. In Windows Vista and Windows 7 it appears an installation error under “device manager”: in both cases, cancel operation, disconnect instrument and restart the complete procedure starting from the beginning of this guide.

## VERIFICATION OF PROPER DRIVER INSTALLATION

To verify the proper installation procedure, proceed as follows.

On Windows 2000 and XP operating systems:

Select “START >> Settings >> Control Panel”, double click on SYSTEM icon. Select “Hardware >> Device Manager”

On Windows Vista and Windows 7 operating systems:

Select “START >> Control panel”, then click on “Device Manager” icon.

Connect instrument to USB port.

The following items should appear:

- “Port (COM and LPT) >> USB Serial Port (COM#)”. The value # is the number assigned to virtual serial port.
- “Controller USB (Universal serial bus) >> USB serial converter”

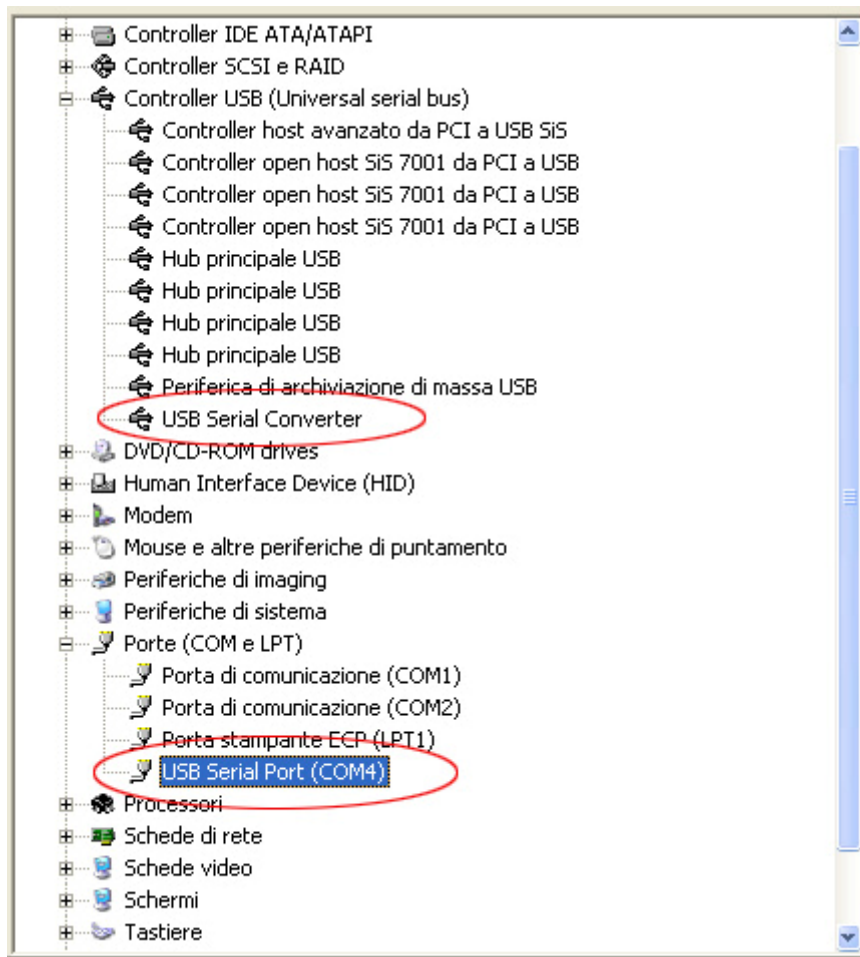

When USB cable is unplugged, the above items will disappear and they will appear again as soon as the instrument is plugged to USB port.

In the documentation supplied with the **Noise Studio** CDROM, it's available a detailed version (including images) of the USB driver management guide.

## HD2010/MC MEMORY CARD READER

The memory card reader HD2010/MC can be used on the sound level meters provided with M12 serial connection. If they aren't provided with M12 input, they can be modified in order to be able to use the memory card reader HD2010/MC.



### DESCRIPTION OF THE INTERFACE FOR MEMORY CARD HD2010/MC

The reader HD2010/MC allows to expand the storage capacity of the sound level meter. By employing SD type or MMC card type, it is possible to record, for example, a sound level profile continuously for several months. In addition, it is possible to download data from the internal memory of the sound level meter to the card. This function can turn very useful when the effected measurements need to be downloaded without moving the device or without using a notebook.

The maximum storage capacity of the card is 2GB, the formatting is FAT16 type.

The reader is powered by the sound level meter and doesn't require any external power supply.

### PREPARATION OF A NEW MEMORY CARD

Every new memory card needs to be formatted before use by means of the appropriate function of the Noise Studio software.

The formatting function requires the PC, on which the Noise studio Software has been installed, to be equipped with a PC Memory card reader (not included in supply). Those are typically included in most recent laptops and desktop computers. Optionally it is possible to use an external memory card, to be connected to an USB port.

#### **How to format a memory card:**

1. If the PC isn't provided with a SD/MMC card reader, connect an external device to the USB port of the PC.
2. Start up the Noise Studio software.
3. Press the key *Instrument management* in Noise Studio: press the key *Memory Card Formatting*.
4. Select the path of the card to be formatted and confirm with ENTER.
5. On the following screen, ensure that the parameter "File System = FAT" has been selected and press START: the card will be formatted.

6. When the message “Formatting completed” appears, press OK for confirmation and CLOSE to exit.
7. Close the Noise Studio software.
8. The formatting has been accomplished and the card is ready for use.

## CONNECTION OF HD2010/MC TO THE SOUND LEVEL METER AND USE OF THE MEMORY CARD

### Connection of the HD2010/MC:

1. Switch off the sound level meter .
2. Connect HD2010/MC to the M12 connector of the sound level meter ensuring the correct fastening of the connector’s ring nut. **While inserting, please make sure that the arrow printed on the reader is turned upwards.** The reader has to be connected to the sound level meter in vertical position.



3. Insert the memory card in the slot of HD2010/MC interface.
4. Switch on the sound level meter and set the menu item “MENU >> General >> Input/Output >> Serial device ” on “MC”.
5. The sound level meter identifies the device. The display of the sound level meter shows “MC connected” and the remaining dimension of memory. The LED on the card reader signalizes the connection.
6. If the display visualizes “Connection failed”, check carefully if the memory card has been introduced correctly into the slot and if the connector is plugged in properly.

**When HD2010/MC interface is connected to the sound level meter, any recording is automatically sent to the memory card rather than to the internal memory of the sound level meter.**

During recording, the LED on the reader flashes upon receipt of every data package. When memory is used up entirely, the recording will be interrupted.

### To disconnect HD2010/MC interface from the sound level meter:

1. Switch off the sound level meter.
2. Disconnect HD2010/MC interface.

**NOTE: Slipping off the memory card while the sound level meter is running and interface is connected causes the loss of all data.**

**In order to replace the memory card, switch off the sound level meter.**



**For disabling HD2010/MC temporarily:**

Set the menu item “MENU >> General >> Input/Output >> Serial device” on a different device than MC.

In order to re-enable the reader, set the menu item on “MC”.

**READING DATA DIRECTLY FROM PC**

In order to read and copy files from the memory card to the PC, use a memory card reader for PC: the card will be recognized as external peripheral mass storage device.

Do not write, cancel or modify the files through the PC.

In order to cancel the memory card, use the formatting function (see chapter “*Preparation of a new memory card*”).

**DATA TRANSFER FROM SOUND LEVEL METER TO MEMORY CARD**

Data can be transferred from the internal memory of the sound level meter to the external memory by executing the sound level meter program “PROG key >> Data download to MC”.

This program allows copying of the measurements recorded in the sound level meter into the external memory card.

The program can be activated only after having connected the memory card interface HD2010/MC, as described in the chapter “*Connection of HD2010/MC to the sound level meter and use of the memory card*”.

During data download, which occurs automatically, the remaining memory space of the card and the

estimation of program completion time are displayed on the screen.

The data transfer from the sound level meter to the memory card **doesn’t** cancel the internal memory of the sound level meter. In order to cancel the content of the internal data memory of the sound level meter, it is necessary to use the Navigator program.

**To cancel the data of the card, use only the formatting function of Noise Studio: the erasure of single files contained in the memory card is not foreseen.**

The Navigator program is not able to manage registrations which have been effected with external devices as interface for HD2010/MC memory card.

**TECHNICAL SPECIFICATIONS**

Type of card	MMC and SD
Maximum capacity	2GB
Power supply	provided by sound level meter
Function indicator	LED on the reader
Connector	8-pole female M12

## TECHNICAL SPECIFICATIONS

The HD2010UC sound level meter is a type 1 or 2 integrating sound level meter with statistical analysis and optional logging.

- ***HD2010UC complies with the following standards***
- IEC 61672:2002-5 Class 1 or Class 2 Group X
- IEC 60651:2001-10 Class 1 or Class 2
- IEC 60804:2000-10 Class 1 or Class 2
- ANSI S1.4:1983 Type 1 or Type 2

### ***Microphone Models***

UC-52, ½ inch pre-polarized (0V) microphone with 20 mV/Pa sensitivity; frequency response optimized for Free Field.

### ***Preamplifier models***

For ½ inch microphones, pre-polarized with 20 mV/Pa sensitivity:

- **HD2010PNE2**: with connection for UC52, ½ inch microphone and driver for extension cable up to 10mt. This preamplifier is provided with CTC device for electrical calibration, it can be directly plugged into the HD2010UC or using the extension cable..
- **HD2010PNE2W**: heated preamplifier with connection for UC52, ½ inch microphone and driver for extension cable. This preamplifier is provided with CTC device for electrical calibration, it can be plugged into the sound level meter or using the 5mt extension cable provided (10mt as an option).

### ***Accessories***

The use of the following accessories does not significantly modify the 2010UC technical specifications:

- HD SAV Windshield (with spectral correction Menu >> Calibration >> Shield >> SAV for type 1 version)
- Extension cable between the preamplifier and the body of the sound level meter up to a maximum of 10m.
- SWD10 stabilized power supply.
- *HD40.1* portable thermal printer.
- VTRAP tripod and HD2110/SA support for the preamplifier.
- Outdoor shield HD WME: (with spectral correction Menu >> Calibration >> Shield >> WME for type 1 version)

## METROLOGICAL CHARACTERISTICS

### Frequency Weighting

- A, C, Z for RMS measurements
- C, Z for peak level measurements

Z weighting is flat along the whole sound spectrum with the following features:

Attenuation [dB]	Frequency Range [Hz]
< 0.1	100 ÷ 20 k
< 1	31.5 ÷ 21 k
< 5	16 ÷ 22.5 k

### Frequency Response

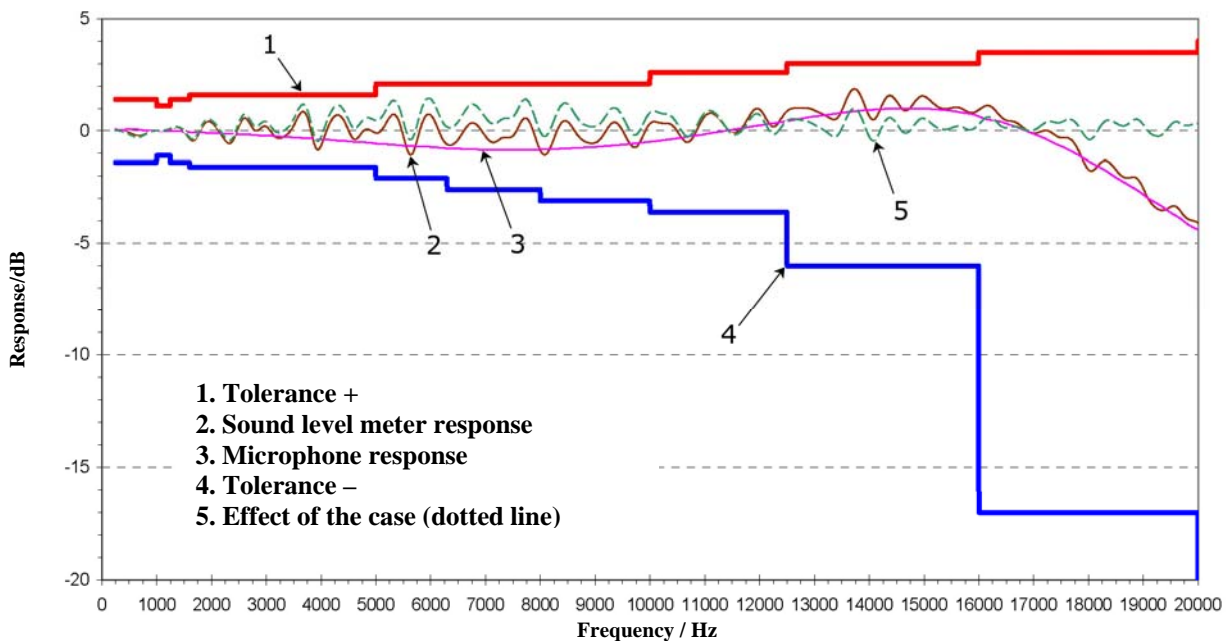

The selection of the UC52 microphones, on the basis of frequency response specifications, and the spectral corrections calculated by the sound level meter DSP allows obtaining a Class 1 response according to IEC61672:2002. The HD2010UC is also available in the Class 2 version.

The frequency response of the microphone depends on the presence of devices like windshield HD SAV or all-weather protection unit HD WME. In order to make measurements with the maximum possible precision in different situations, the HD2010UC sound level meter can automatically apply spectral corrections needed to measure in random field conditions, or with the windshield or with the all-weather outdoor protection. Spectral correction for diffuse field measurement is enabled setting parameter Menu >> Calibration >> Mic.Resp.Correction >> RI while correction for HD SAV mounted, is enabled setting parameter Menu >> Calibration >> Shield >> SAV.

For more information on the applied corrections please refer to the UC52 microphone manual.

### HD WME outdoor protection

The windshield and rain protection units mounted on HD WME outdoor protection, modify microphone frequency response: in order to apply the correction to sound level meter overall re-

response, it's necessary to set the specific parameter Menu >> Calibration >> Shield >> WME. With this setting applied, HD2010UC sound level meter with HD WME protection, fully complies to type 1 specifications according to IEC 61672 standard; in such configuration, when used in vertical position, the sound level meter is able to measure accurately environmental noise from above (0° incidence) like for example the noise generated by aircraft overflights.

When parameter Menu >> Calibration >> Shield is set to WME and microphone acoustic response ( menu Calibration >> Mic.Resp.Correction) is set to RI, it's applied a frequency spectral correction to obtain a flat frequency response in a diffuse field. Using this setting the HD2010UC sound level meter with HD WME outdoor protection mounted in vertical position, is suitable for measurements of environmental community noise due to noise sources on the ground (road traffic noise, railway noise...).

For more information on spectral correction applied to HD2010UC sound level meter when used with HD WME outdoor protection, please refer to UC52 microphone user manual.

### *Self-generated Noise*

The intrinsic noise, measured replacing the microphone with the capacitive adapter,, is shown in the following tables according to the different frequency weightings, either for **RMS** level or **peak level** measurements:

Input Gain [dB]	Intrinsic noise [dB]				
	LpA	LpC	LpZ	LpkC	LpkZ
<b>0</b>	50	49	53	61	65
<b>10</b>	40	39	43	51	55
<b>20</b>	31	32	36	45	48
<b>30</b>	26	30	33	43	45
<b>40</b>	24	29	33	43	45

### *Linearity range*

The lower limit of the linearity range, was calculated as the maximum between the upper limit decreased by 80dB and the self-generated noise increased by 7dB. The upper limit is equal to 141dB with a input gain equal to 0 dB and decrease by 10 dB for every 10 dB gain increment.

The linearity range is almost independent of frequency in the 31.5 Hz ... 12.5 kHz interval, and it is shown in the following table according to the input gain:

Input Gain [dB]	Parameter	Lower Limit [dB]	Upper Limit [dB]
<b>0</b>	<b>LpA</b>	60	141
	<b>LpC</b>	60	
	<b>LpZ</b>	60	
	<b>LpkC</b>	68	144
	<b>LpkZ</b>	72	
<b>10</b>	<b>LpA</b>	50	131
	<b>LpC</b>	50	
	<b>LpZ</b>	50	
	<b>LpkC</b>	58	134
	<b>LpkZ</b>	62	
<b>20</b>	<b>LpA</b>	40	121
	<b>LpC</b>	40	
	<b>LpZ</b>	43	
	<b>LpkC</b>	52	124
	<b>LpkZ</b>	55	

Input Gain [dB]	Parameter	Lower Limit [dB]	Upper Limit [dB]
30	LpA	33	111
	LpC	37	
	LpZ	40	
	LpkC	50	114
	LpkZ	52	
40	LpA	31	101
	LpC	36	
	LpZ	40	
	LpkC	50	104
	LpkZ	52	

The starting level for the linearity range detection matches the reference level (94 dB) at 1 kHz. With different frequencies, the starting level takes into account the attenuation of the frequency weighting being measured. In the secondary fields the starting level is subject to the same increment of the input gain.

### **Integration Time**

It can be set from a minimum of 1s to a maximum of 99 hours.

### **Measurement Dynamics with Electromagnetic Fields**

Minimum measurable level equal to 60dBA with carrier from 26 MHz to 1 GHz and amplitude equal to 10V/m modulated 80% at 1 kHz.

### **Reference Conditions**

- The measuring range is that with input gain equal to 10 dB.
- The level corresponds to 94 dB.
- The acoustic calibration can be performed at a sound level included in the range 94dB ÷ 124dB.
- The reference direction of the acoustic signal is that of the preamplifier longitudinal axis.
- The reference acoustic field is the free field

### **Operating conditions**

- Storage temperature: -25 ÷ 70°C.
- Operating temperature: -10 ÷ 50°C.
- Working relative humidity: 25 ÷ 90%RH, not condensing.
- Static pressure: 65 ÷ 108kPa.
- Protection degree: IP64.

In case of condensation growth, it must evaporate completely before using the sound level meter.

### **Drifts**

- Temperature: ± 0.3 dB over the range -10 ÷ 50°C (with correction for microphone drift activated).
- Relative humidity: ± 0.3 dB over the range 25 ÷ 90%RH, not condensing.
- Static pressure: ± 0.3 dB over the range 65 ÷ 108kPa.

## ELECTRICAL CHARACTERISTICS

### Pre-heating time

Lower than 10 seconds.

### Power Supply

- Batteries: 4 alkaline or rechargeable AA 1.5V internal batteries. The sound level meter does not have a battery charger.
- Autonomy: >12 hours in RUN mode with alkaline good-quality batteries. Amounting to 8 hours when using the outdoor microphone unit HD WME fitted with heated preamplifier.
- External batteries: It is possible to connect external batteries to the sound level meter through the male connector for external power supply ( $\varnothing$  5.5mm socket). The positive (pole) power supply must be connected to the central pin. The battery should supply  $9 \div 12$  V at about 200mA/h. The maximum limit for external power supply is 15V.
- Mains: mains adapter with 9-12Vdc/300mA continuous voltage.
- Switch-off: selectable auto-power-off.

When battery voltage falls below 3.9V, the sound level meter cannot perform any measurement. However it is possible to access and download the data in the internal memory. Under 3.5V, the instrument will automatically shut off. Logged data and configuration parameter are maintained even without power supply.

### Input maximum levels

The maximum tolerable sound level with UC52 microphone is 146 dB.

The level of the electrical signal applicable to the microphone input, despite the replacement of the microphone capsule with the proper capacitive adapter, must not exceed 10Vrms.

### LINE Output

- 3.5mm  $\varnothing$  mono jack
- Preamplifier output signal
- Unweighted output protected against short-circuit  
Gain:  $\sim .3$  mV/Pa and  $\sim 30$  mV/Pa respectively for an input gain equal to 0 dB and 20 dB, not calibrated
- Linearity: 100 dB with maximum output level equal to 1.2Vrms
- Series impedance: 1k $\Omega$
- Typical Load: 100k $\Omega$

### DC Output

- 2.5mm  $\varnothing$  mono jack
- Short-circuit protected output
- A weighted output with FAST time constant updated 8 times/s
- Gain: 10 mV/dB
- Linearity: 80dB
- Series impedance: 1k $\Omega$
- Typical Load: 100k $\Omega$

### ***Serial interface***

- Socket: 8-way M12
- Type: RS232C (EIA/TIA574) or USB 1.1 or 2.0 not insulated
- Baud rate: between 300 and 230400 baud
- Data bits: 8
- Parity: None
- Stop bits: 1
- Flow control: Hardware
- Cable length: max 15m

### ***Extension Cable for the Microphone***

The microphone preamplifier can be connected to the sound level meter body through an extension cable up to 10m long (CPA). The sound level meter specifications are not significantly modified by the cable presence.

## **STATISTICAL ANALYSIS**

Acoustic descriptor  $L_{AFp}$  or  $L_{eq}$  Short or  $L_{pk}$

Sampling 1/8 s.

Classes from 0.5 dB.

Measurement range: 30 dB ÷ 140 dB.

4 percentile levels, programmable between  $L_1$  to  $L_{99}$ .

### ***Statistical graphs calculation and display (“Advanced Data Logger” option).***

Graph of distribution probability of the levels

Graph of the percentile levels from  $L_1$  to  $L_{99}$ .

## **DISPLAY**

### ***Graphic display***

128x64 pixels backlit on a 56x38mm surface.

### ***Mode:***

- SLM (sound level meter) screen with 3 selectable parameters.
- Time profile of the A weighted sound pressure level with FAST time constant according to 1/8s intervals (with “Advanced Data Logger” option”).
- Level distribution of probabilities in 0.5dB, 1dB or 2dB classes (with “Advanced Data Logger” option”).
- Percentile levels graph from  $L_1$  to  $L_{99}$  (with “Advanced Data Logger” option”).

## STORAGE OF MEASUREMENTS

The basic version is fitted with a permanent 4 MB memory, corresponding to over 500 single measurements. If “Advanced Data Logger” option is installed the memory capacity can be doubled to 8 MB ( “memory module” option).

In this case it's possible to store:

- Continuous recording mode: almost 24 hours of recording (3 parameters twice per second plus 1 parameter 8 times per second)
- Auto-Store mode: over 80 days of recording (3 parameters on 1 minute intervals).
- Report mode: over 5 days of recording on 1 minute interval of 5 user selectable parameters and complete statistical analysis.

### *Security of stored data*

Unlimited, independent of battery charge

## PROGRAMS

### *Calibrations and Diagnostic Programs*

- Acoustic calibration at 1kHz using a sound level calibrator included in the range: 94dB ÷ 124dB
- Electrical calibration with built-in generator.
- “Diagnostic check” program”.

### *Interface and processing programs using a PC*

- **NoiseStudio (basic version)** for download and graphic display of stored data, as well as for instrument configuration.

Noise Studio includes a number of optional modules for analysis and post-processing of noise measurements captured using the Delta Ohm sound level meters. The functions in these modules are specifically developed for given applications (such as noise analysis in the workplace or railway traffic noise analysis) and can be enabled on a licence protected hardware key (CH20).

- **“Workers Protection”** module – cod.**NS1** module is used to get and process the sound measurements performed in workplaces. Data are transferred from the sound level meter memory to the PC using the Noise Studio program. Here, they can be processed in compliance with the Italian and European Community rules concerning noise in workplaces.
- **“Acoustic Pollution”** module – cod.**NS2A** – module for acoustic climate analysis on a daily, weekly and annual basis including road, railway and airport noise. The software performs statistical and spectral analysis and automatically identifies noisy events. The analyses are performed in compliance with the national (D.L.194/2005 and D.M. 16/03/1998) and EU legislation regarding the acoustic pollution and the mapping of the territory. (NS2A analysis request “advanced data logger” to be installed in the sound level meter).
- **“Monitor”** module - cod.**NS4** - for the acoustic monitoring and remote control via PC or via modem. Programmed acquisition, event identification and synchronized audio recording.

For a detailed description of the currently available analysis functions, contact your authorized dealer.



### ***Firmware***

To be upgraded via the serial port with NoiseStudio software

## **OTHER CHARACTERISTICS**

### ***Printing***

- Direct printing of logged parameters (printing of a single event)
- Continuous Printing (Monitor).

### ***Case***

- Dimensions (Length x Width x Height): 445x100x50mm equipped with preamplifier
- Weight: 740g (batteries included)
- Materials: ABS, rubber

### ***Time***

- Date and time: clock and date updated in real time
- maximum deviation is less than 1min/month

## REFERENCE STANDARDS

- IEC 60651:2001, Class 1 or 2.
- IEC 60804:2000, Class 1 or 2.
- IEC 61672-1:2002, Class 1 or 2 Group X
- ANSI S1.4-1983, Type 1 or 2.

## EMC STANDARD REGULATIONS

- |                                                                                                                     |                      |
|---------------------------------------------------------------------------------------------------------------------|----------------------|
| • Protection degree                                                                                                 | IP64                 |
| • Safety                                                                                                            | EN61010-1            |
| • Electromagnetic compatibility. Immunity general standard. Industrial environment.                                 | EN61000-6-2:2005     |
| • Electromagnetic compatibility. Immunity general standard. Residential environment, commercial and light industry. | EN61000-6-3:2007     |
| • Electrostatic discharges                                                                                          | EN61000-4-2 level 3  |
| • Susceptibility to EMI                                                                                             | EN61000-4-3 level 3  |
| • Fast electric transients                                                                                          | EN61000-4-4 level 3  |
| • Immunity to conducted disturbances                                                                                | EN61000-4-6          |
| • Electromagnetic interference – Conducted emissions                                                                | EN55022:2007 class B |
| • Electromagnetic interference – Radiated emissions                                                                 | IEC/CISPR 22 class B |

## ITALIAN LAWS

- Noise in working environment: D.L. 81/2008, UNI 9432/2011, ISO9612/11 and Directive 2008/46/CE.
- Acoustical climate assessment and monitoring (“Advanced Data Logger” option) with sound events capture (“Advanced Data Logger” option”)
- Noise of entertainment dancing spaces: D.P.C.M. 215 del 16/04/99
- Noise emission from machines D.L 262 del 04/09/2002, Directive 2000/14/CE and 2005/88/CE

## ORDERING CODES

### **HD2010UC kit 1:** type 1 integrating sound level meter kit with 4MB memory

The kit includes the HD2010UC class 1 integrating sound level meter, HD2010PNE2 preamplifier, UC52/1 free field microphone, microphone extension cable CPA/5, RS232 null-modem serial cable for connection of COM ports (HD2110/RS) or USB (HD2110/USB), HD\_SAV windshield, NoiseStudio PC software (basic version), plastic carrying case, instruction manual.

The kit includes: Calibration certification according to IEC 60651 and IEC 60804, of the measurement chain including sound level meter, preamplifier HD2010PNE2 and microphone.

### **HD2010UC kit1E:** type 1 integrating sound level meter with outdoor weather protected preamplifier and microphone:

Suitable for **outdoor measurements**

- Microphonic outdoor protection HD WME
- Heated preamplifier HD2010PNE2W with 5mt cable (up to 10m on request)

### **HD2010UC kit1IE:** type 1 integrating sound level meter with standard preamplifier + outdoor weather protected preamplifier and microphone:

Suitable for **outdoor and indoor measurements:**

Compared to the version “HD2010UC Kit1” also includes:

- Heated preamplifier HD2010PN2W with 5mt extension cable (up to 10m on request)
- Microphonic outdoor protection HD WME
- Calibration certificate according to IEC 60651 and IEC 60804, of the measurement chain including sound level meter, preamplifier HD2010PNE2 and microphone

### **HD2010UC kit 2:** type 2 integrating sound level meter kit with 4MB memory

The kit includes the HD2010UC class 2 integrating sound level meter, HD2010PNE2 preamplifier, UC52 free field microphone, microphone extension cable CPA/5, RS232 null-modem serial cable for connection of COM ports (HD2110/RS) or USB (HD2110/USB), HD\_SAV windshield, NoiseStudio PC software (basic version), plastic carrying case, instruction manual,.

The kit includes: Calibration certification according to IEC 60651 and IEC 60804, of the measurement chain including sound level meter, preamplifier HD2010PNE2 and microphone.

### **HD2010UC kit2E:** type 2 integrating sound level meter with outdoor weather protected preamplifier and microphone:

Suitable for **outdoor measurements**

Preamplifier, windscreen and extension cable of HD2010UC.Kit2 are replaced by

- Microphonic outdoor protection HD WME
- Heated preamplifier HD2010PNE2W with 5mt cable (up to 10m on request)

### **HD2010UC kit2IE:** type 2 integrating sound level meter with standard preamplifier + outdoor weather protected preamplifier and microphone:

Suitable for **outdoor and indoor measurements :**

Compared to the version “HD2010UC Kit2” also includes:

- Heated preamplifier HD2010PN2W with 5m extension cable (up to 10m on request)
- Microphonic outdoor protection HD WME
- Calibration certificate according to IEC 60651 and IEC 60804, of the measurement chain including sound level meter, preamplifier HD2010PNE2 and microphone

### *Options, accessories and software*

**HD2010.O0 “Memory module”:** 4 MB memory expansion. It requires the HD2010.O2 “Advanced Data Logger” option.

**HD2010.O2 “Advanced Data Logger”:** sound level profiles automatic recording, full statistic analysis, capture and analysis of sound events with trigger function, simultaneous data logging of profiles, reports and events. “Navigator” program for reviewing stored data.

**HD2020:** type 1 acoustic calibrator according to IEC60942:2003 with LCD display. Frequency: 1000Hz; sound level: 94dB/114dB.

**HD9101:** calibrator type 1 according to IEC60942:1998. Frequency: 1000Hz; sound level: 94dB/114dB.

**HD9102:** calibrator type 2 according to IEC60942:1998. Frequency: 1000Hz; sound level: 94dB/114dB.

**CPA/10:** 10m extension cable for HD2010PNE2 preamplifier.

**SWD10:** stabilized power supply with  $V_{in}=100\div 240V_{ac}$  /  $V_{out}=12V_{dc}/1000mA$ .

**VTRAP:** tripod, max. height 1550mm.

**VTRAP.H4:** tripod, max. height 4 m

**HD2110/SA:** support to fix the preamplifier to the tripod.

**HD2110RS:** RS232 serial cable null-modem with DB9 standard connector.

**HD2110USB:** USB cable with A type connector

**HD40.1:** the kit includes: 24-column portable thermal printer, serial interface, 57mm paper width, four NiMH 1.2V rechargeable batteries, SWD10 power supply, instruction manual, 5 thermal paper rolls.

**HD2010MC:** module for datalogging and data download to MMC and SD type memory cards. One 1 GB SD card is included.

### *Post processing software modules*

**CH20: Hardware key** for PC with Windows operating system. When connected to USB port, it enables the use of the Noise Studio software modules.

**NS1 “Workers Protection”** module. Analysis of the noise and vibrations exposure in the workplace in compliance with D.L. 81/2008, UNI 9432:2011 and ISO 9612:2009 norms. Calculation of the exposure levels and related uncertainties and evaluation of the individual protection devices effectiveness, of the noise sources pulse index and of the presence of the DC-shift phenomenon in the hand-arm transmitted vibrations analysis.

**NS2A “Acoustic Pollution”** module. Acoustic climate analysis on a daily, weekly and annual basis including road, railway and airport noise. The software performs statistical and spectral analyses and automatically identifies noisy events. The analyses are performed in compliance with

the national (D.L. 194/2005 and D.M. 16/03/1998) and EU legislation regarding the acoustic pollution and the mapping of the territory.

**NS4 “Monitor”** module. Acoustic monitoring and PC remote control. Programmed data acquisition, events identification and synchronized audio recording.

## **ACCESSORIES AND SPARE PARTS**

**UC52/1:** Type 1 Free Field prepolarized condenser microphone.

**UC52:** Type 2 Free Field prepolarized condenser microphone

**HD WME:** outdoor microphone weather protection. Includes: HD WME3 stainless steel support for preamplifier, windshield HD SAV3, rain protection HD WME2, anti-bird spike HD WME1.

**HD WME1:** anti-bird spike for HD WME weather protection.

**HD WME2:** rain protection for HD WME.

**HD SAV3:** windshield for HD WME weather protection.

**HD SAV:** windshield for ½” microphones.

**BAT-40:** Spare battery pack for HD40.1 printer.

**RCT:** 4 rolls of thermal paper, 57 mm width and 32 mm diameter.

**HD2010PNE2:** Microphone preamplifier equipped with CTC device for electrical calibration and driver for cable up to 10 m.

**HD2010PNE2W:** Heated preamplifier for HD WME outdoor microphone unit. It is equipped with CTC device for electrical calibration and driver for cable up to 10 m. 5 m connection cable (10 m on request).

**CPA/5:** 5 m extension cable for HD2010PNE2,

## WHAT SHALL I DO IF ...

This chapter deals with the step by step description on how to carry out the most recurrent measurements in the acoustic field with the HD2010UC sound level meter. If necessary, see the description of the key functions from page.92 and the different display modes from page 13.

### MEASUREMENT PROCEDURE

When the “Advanced Data Logger” option is active, the HD2010UC sound level meter can acquire 3 parameters of SLM screen simultaneously (twice/second), as well as the A weighted sound level with FAST time constant (8 times/second). The available parameters are those listed in the tables of appendix A1, on page 98.

**Sound Level Meter (SLM)** – See also the description on page 15.

Use the MODE key to select the SLM display, where 3 measuring parameters are shown in numeric format. Press SELECT repeatedly to set the integration time (Tint), the measuring range and the parameters to be displayed as described in the paragraph “*Selecting Parameters*” of chapter “*SLM (sound level meter) Mode*” on page 15.

Alternatively, measuring parameters can be set from menu, as described in the chapter “DESCRIPTION OF THE MENU FUNCTIONS on page” 35. Alternatively, measuring parameters can be set from menu, as described in the chapter.

If the sound level meter is set to the single integration mode (MENU >> Instrument >> Measurement >> Integration Mode: SINGLE), when the Tint time is over, the HOLD indication will appear and display update will stop. Now you can print or store the values. Meanwhile, the instrument goes on measuring: to continue display updating, just press the HOLD key. When the continuous recording is activated (**with the “Advanced Data Logger” option**) and the Tint time goes over, the acquisition is stopped automatically.

If you press HOLD during the measuring phase, the display update will be temporarily interrupted. When HOLD is pressed again, the updating will continue. Even if the display is not updated, the instrument will go on measuring.

Pressing PAUSE, acquisition and calculation of the integrated parameters will be temporarily interrupted. When in PAUSE, the calculation of integrated parameters, such as, for example, Leq and the maximum levels, is suspended; in this phase the contribution of the last seconds of acquisition can be deleted using the “Back-Erase” function and the LEFT and RIGHT keys, as described in the paragraph: “*Back-Erase Function*” on page 16. While in PAUSE, all integrated parameters can be cleared pressing START/STOP/RESET. Press PAUSE once more to start measuring again.

Press PRINT at any time to print the on-screen data. To activate the continuous printing (*Monitor*), press and hold down PRINT for at least 2 seconds. A flashing **M** overlapping the status indicator, shows that the Monitor function is active. The Monitor function remains active even jumping to other measuring views and can be disabled pressing PRINT again or START/STOP/RESET to stop measurement.

If, on the contrary, the sound level meter is set with the *multiple* integration mode (MENU >> Instrument >> Measurement >> Integration Mode: MULT), the integrated levels are cleared just before the beginning of each measurement cycle. The MONITOR function allows sending to the serial interface the integrated spectrum at intervals equal to the Tint time. Recording in Auto-Store mode allows to store on memory octave and third octave (if this option is installed) spectra together with the parameters displayed on the SLM screen at a rate corresponding to the Tint time.

Press REC for 2 seconds at any time to store the displayed data. As soon as data are saved on memory, a screen will allow you to enter the recording title. If single data recording is activated with the sound level meter in STOP mode and the “Advanced Data Logger” option is installed, a screen allowing activating the Auto-Store will appear first.

**History Mode (Time Profile)** - See also the description on page 18.

With the MODE key you can open the PROFILE screen (requires the “Advanced Data Logger” option) in which the time profile of the A weighted sound pressure level with FAST time constant is shown graphically. The sampling interval is equal to 1/8s.

You can start the measurements by pressing the START/STOP/RESET key.

If the sound level meter is set to the single integration mode (MENU >> Instrument >> Measurement >> Integration Mode: SING), once the Tint time (defined in the SLM page), is over, HOLD will be displayed: display update will stop. Meanwhile, the instrument goes on measuring: to continue display updating, just press the HOLD key. When the continuous recording is activated and the Tint time goes over, the acquisition is stopped automatically.

If you press HOLD during the measuring phase, the display update will be temporarily interrupted. When HOLD is pressed again, the updating will continue. Even if the display is not updated, the instrument will go on measuring.

If you press PAUSE, the acquisition will be temporarily suspended. While in pause, press START/STOP/RESET to clear the graph. Press PAUSE once more to start measuring again.

If you press CURSOR at any moment, a cursor will be activated. If you press CURSOR once more, a second cursor will activate, while, if you press it for the third time, both cursors will be activated in “tracking”. Use the LEFT and RIGHT arrows of the keypad to shift the selected cursors into the desired position to indicate the measured level and the corresponding acquisition time. Press CURSOR again to disable cursors.

PRINT at any time to print the on-screen data. To activate the continuous printing (Monitor), press and hold down PRINT for at least 2 seconds. The flashing letter M, over the status indicator, indicates that the Monitor function has been activated. The Monitor function remains active even when jumping to other measuring views and can be disabled pressing PRINT again or START/STOP/RESET to stop measurement.

## STORAGE OF MEASUREMENTS WITH THE “ADVANCED DATA LOGGER” OPTION

The HD2010UC, sound level meter, when provided with the “Advanced Data Logger” option, offers two different storage modes:

1. The **Continuous Recording** (press REC and START keys simultaneously) implies the storage of the SLM screen-page (2 samples a second) together with the time profile of the A weighted sound pressure level with FAST constant time (8 samples a second). It's also possible to store the data of “Report and Events groups”, each consisting of 5 programmable parameters and full statistical analysis. The data of the “Event group” are stored at the end of each event and the data of “report group” are stored at programmable intervals from 1 sec to 1 hour. The REC symbol as status indicator shows when the sound level meter is recording. If you press STOP, recording will be stopped and you will be asked to confirm the title. While recording, you can press PAUSE to suspend recording.

When integration mode is multiple (MENU >> Instrument >> Measurement >> Integration Mode: MULT), the integrated levels are cleared just before the beginning of each measurement cycle. A special marker identifies the last acquired data per each cycle.

2. The **Auto-Store** mode can be activated either through the parameter MENU >> Recording >> Auto-Store or by pressing REC and holding it down for at least 2 seconds with the sound level meter in STOP mode. Then select the AUTO option when you are requested to choose the recording option. Activating the Auto-Store recording mode together with the multiple integra-

tion mode (MENU >> Instrument >> Measurement >> Integration Mode: MULT) allows to record at intervals equal to the set integration time (MENU >> Instrument >> Measurements >> Integration interval) the data displayed on SLM screen.

Set in this way and once the integration time has been reached, the sound level meter will first record data, then set all integrated levels to zero, and finally start a new integration period. The flashing REC symbol, overlapping the status indicator, shows that the sound level meter is recording. Press START to start recording and STOP to stop it. A flashing REC over the RUN status indicator, shows when the sound level meter is recording. Press REC with the instrument in STOP to disable the Auto-Store and the multiple integration modes. The Auto-Store recording mode combined with the single integration mode (MENU >> Instrument >> Measurement >> Integration Mode: SINGLE) allows to record automatically data displayed on SLM, OCTAVE and T.OCTAVE (with option) screens at the end of the set integration interval (MENU >> Instrument >> Measurements >> Integration Interval); the measurement will be automatically interrupted immediately after recording.

3. **Single screen** storage is obtained by pressing REC for at least 2 seconds when the instrument is in RUN or STOP mode. If the instrument is in STOP mode, and the “Advanced Data Logger” option is installed, you will be prompted to choose between automatic (AUTO) and manual (MAN) storage; the current screen will be stored if choosing the latter.

The *Continuous Recording* allows recording the time profile of instantaneous and integrated levels. This means that you can record, for example, the sound pressure level with FAST time constant 8 times a second and, at the same time, the sound pressure levels with SLOW time constant, the peak level, and the Leq over 0.5s twice a second.

The Auto-Store recording mode, combined with the multiple integration mode, allows instead to store sound levels at prefixed intervals, resetting them automatically at the beginning of each interval. Thus you can record, for example, the Leq, the SEL, the maximum sound pressure level with SLOW time constant, at intervals programmable between 1s and 99 hours.

## MEASUREMENT OF NOISE DOSE

The **Dose** represents the percentage of a maximum value of noise exposure throughout a day.

$$D(Q) = \frac{100}{T_c} \cdot \int_0^T 10^{\frac{L-L_c}{q}} dt$$

where:

D(Q) = exposure percentage for an Exchange Rate equal to Q.

T<sub>c</sub> = daily exposure time (usually 8 hours).

T = measurement time.

L = sound pressure level when it is higher than the Threshold Level, and -∞ otherwise.

L<sub>c</sub> = Criterion Level for a daily exposure corresponding to 100% of the dose.

Q = Exchange Rate.

q = parameter independent of the exchange rate and equal to:

- 10 for Q = 3dB
- 5/log2 for Q = 5dB
- 4/log2 for Q = 4dB



The sound level meter calculates the following parameters: *DOSE (A)*, the percentage of the daily effective dose, and *DOSE,d (A)*, the estimated daily DOSE according to the programmed parameters.

The DOSE calculation is characterized by three parameters:

1. ***DOSE Criterion*** is the SPL constant value, which continuous exposure for 8 hours determines a 100% DOSE.
2. ***DOSE Threshold*** that represents the SPL level under which the DOSE is not increased.
3. ***Exchange rate*** is the variation of the SPL value that determines a double or half duration of exposure with the same DOSE Criterion. Provided values are 3, 4 or 5dB.

The three configuration parameters are contained in the submenu Measurement (MENU >> Instrument >> Measurement): once they have been set, select the submenu Sound Level Meter (MENU >> Sound Level Meter) and choose, according to the type of measurements to be made, between the parameters DOSE (A) or DOSE,d (A).

The integration time can be entered directly in the SLM measuring window. Now the instrument is ready to carry out the measurement: press START. After Tint time has elapsed, the instrument turns into the HOLD status and displays the DOSE calculated over the set time.

## STATISTICAL ANALYSIS

Up to 3 percentile levels are selectable in the SLM display mode (MENU >> Instrument >> Measurement >> Percentile Lev. 1-4), programmable between  $L_1$  and  $L_{99}$ . The statistical analyzer samples the sound pressure A weighted level with FAST time constant, 8 times a second; the levels are accumulated in 0.5dB classes. The percentile levels are calculated interpolating the cumulative distribution.

The “Advanced Data Logger” option can be used to choose which parameter the statistical analysis is performed on: equivalent level, sound pressure level with FAST time constant, and peak level. The complete statistical analysis is available with the distribution of probabilities graph and the  $L_1$  to  $L_{99}$  percentile level graph.

## DATA PRINTING

The displayed values can be printed at any time in all display and acquisition modes. Besides the *Monitor* function can be activated via the serial line when you press PRINT and hold it down for 2 seconds. This function allows to continuously send displayed data in real time to the serial interface. The transferred data are those of the active display mode at the time PRINT was pressed. Data are continuously transferred until PRINT is pressed again, or until the acquisition is stopped. The Monitor function can be activated even in the STOP acquisition mode; it will start as soon as the instrument turns into RUN mode. The Monitor works independently from any recording of data on memory.

**Using the Monitor function it is possible, with the help of a PC, to make measurements limited only by the PC storage capacity.**

## TROUBLESHOOTING

The HD2010UC sound level meter is provided with a diagnostic program (DIAGNOSTIC CHECK) that automatically checks the instrument main parameters. This program can be run at any time to check the instrument operating conditions (see description on page 54).

One of the parameters being analyzed is the sensitivity of the amplification channel that includes, through a charge partition circuit (CTC), the microphone capacity. Measurement is made at 1kHz.

### DIAGNOSTIC CHECK

1. *The DIAGNOSTIC CHECK program fails*

Replace batteries and try again after waiting for the end of the stabilization time and, if the problem remains, contact service.

### CALIBRATION

1. *The ELECTRIC CALIBRATION program fails*

Ensure that the instrument is not subject to high noise and/or vibrations.

Try again after having waited for the end of the stabilization time and, if the problem remains, run the ACOUSTIC CALIBRATION program.

2. *The ACOUSTIC CALIBRATION program fails*

Ensure that the instrument is not subject to high noise and/or vibrations and that acoustic calibrator and sound level meter are steadily aligned and that the microphone is properly plugged in the calibrator cavity. Check that the seal rubber ring is present and undamaged.

Try again after having waited for the end of the stabilization time and, if the problem remains, load the factory calibration following these steps:

- Ensure that acquisition is on STOP.
- Remove one of the batteries while the instrument is switched on: this operation ensures that all the instrument internal circuits are discharged.
- Press and **hold ENTER down**, and then insert the battery you had removed. The instrument will switch on and will display a warning relevant to the load of factory calibration. Release ENTER and press the key on the right near the CONTINUE key.
- After having waited for the stabilization time, run the program ACOUSTIC CALIBRATION.

Should the program fail, contact the service department.

### RESTORING FACTORY SETUP

The default configuration of the instrument parameters (factory setup) can be recalled at any time by means of a combination of keys. **This operation does not clear the content of data memory.**

While the instrument is off, press and hold down ENTER and power on the sound level meter. All the menu items are simultaneously brought back to the default value.

### RESTORING FACTORY CALIBRATION

The Factory Calibration can be recalled at any time by means of a combination of keys. **This operation does not clear the content of data memory.**

While the instrument is off, remove one of the batteries and wait at least 5 minutes for the sound level meter internal circuits to discharge.

Press and hold down the ENTER key while reinserting the battery: the sound level meter will automatically turn on. Confirm the load of factory calibration.

The sound level meter calibration parameters are restored to the last factory calibration; all menu items are simultaneously brought back to the factory parameters (default).

## MISCELLANEOUS PROBLEMS

1. *The instrument does not turn on after battery replacement.*
  - Remove one of the batteries and wait at least 5 minutes before reinserting it. The instrument should turn on automatically when the battery is inserted.
2. *The detected sound levels seem incorrect.*
  - Ensure that no condensation is present on the capsule or preamplifier. Avoid turning on the instrument in conditions of possible condensation growth. Use the outdoor microphone unit HD WME to perform measurements in conditions of high humidity or when it is raining.
  - Check that the warm-up time, indicated by a blinking letter “W” over the upper left status indicator, has elapsed.
  - Check measurement accuracy using the acoustic calibrator.
  - Load factory calibration.
  - Check that the microphone protection grid is screwed down on the capsule securely.
3. *Upon turning the sound level meter on, it turns off automatically right after the introduction screen.*
  - The batteries are flat.
4. *The sound level meter does not communicate with the PC.*
  - Check that the sound level meter and PC communication speed is the same (MENU >> Instrument >> Input/Output >> Baud Rate).
  - Check that the connection cable is plugged correctly in the sound level meter and is connected to a PC serial port or USB with the item MENU >> Instrument >> Input/Output >> Serial device set up respectively on RS232 or USB respectively.
  - If you use a USB interface, check that the driver is correctly installed.
  - If you use a Noise Studio program, disable the AutoDetect function (Menu Option >> Port Settings) and set the connection directly to the COM port to which the instrument is connected with the same baud rate of the sound level meter (Menu >> Instrument >> Input/Output >> Baud Rate).
5. *It is not possible to activate continuous recording. By pressing REC and RUN, the instrument starts measurements without recording.*
  - The instrument does not have available memory for additional data. Download the data and/or erase the memory.
  - The “Advanced Data Logger” option is not installed.

## KEYBOARD DESCRIPTION



### HOLD key

The HOLD key can be used to temporarily suspend the display update while the instrument continues making the requested measurements. A “H” in the left corner at the top shows that the display is in this phase. Press the key again to go back to standard measurement. While the instrument is in HOLD mode, you can jump from a screen-page to the other, activate the cursors on the graphic pages, print and store data. Recording and the Monitor function are not affected by the HOLD status.



### ON/OFF key

To switch on or off the instrument, press the ON/OFF key **for at least one second**. Upon the power on, the instrument shows for a few seconds the manufacturer’s logo and the program version. Then it switches to the SLM working mode (Sound Level Meter) and displays 5 instantaneous or integrated measurement parameters in numeric form.

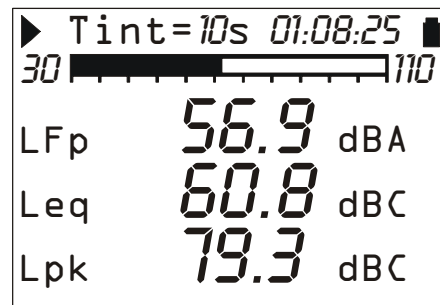
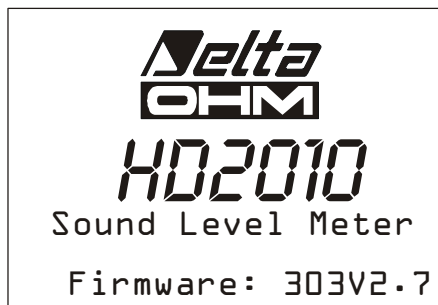

Before switching off the instrument, press STOP to end the ongoing measurement. If you do not do it, a message will request you to stop the measurement in progress: “WARNING! Stop the measurement to continue”.

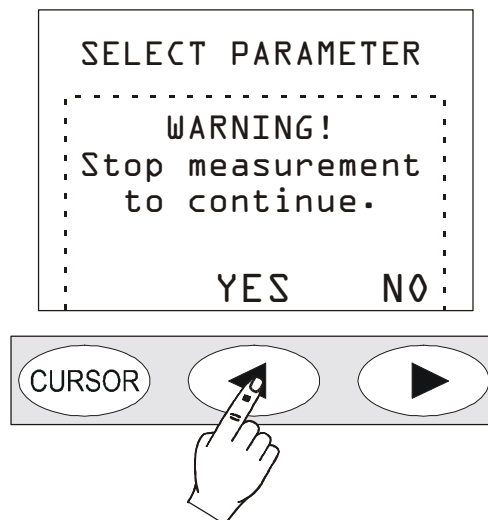

Press YES and then ON/OFF to switch off the instrument.

## Auto Power Off Function

The instrument is provided with the Auto-PowerOff function that switches automatically off the instrument after 5 minutes when it is in STOP and no key is pressed in this time interval. Before switching off, the instrument will make a series of beep: in this phase you can press a key to prevent the instrument from switching off.

The function can be disabled from the MENU via the "Auto-Power-Off" item (MENU >> Instrument >> System >> Auto-Power-Off = OFF). In this case, the battery symbol flashes to remind the user that the instrument will not switch off automatically, but only if the <ON/OFF> key is pressed. The *Auto-Power-Off* function is temporarily disabled when an external power supply is used or when the instrument is recording or running a program.



### MENU key

The HD2010UC sound level meter requires, according to its use, many parameters to be set. If you press MENU, you can access all instrument parameters, for the following functions:

- Main
- Sound Level Meter (SLM)
- statistical analyzer (“Advanced Data Logger” option)
- Trigger (“Advanced Data Logger” option)
- Recording (“Advanced Data Logger” option)
- Calibration
- Sequencer (“Advanced Data Logger” option)

Inside the menus you can:

- Move from one item to the other within the same menu by means of the UP and DOWN arrows,
- Press SELECT to choose an item to be modified,
- Use the UP and DOWN keys to modify the selected parameter,
- Press ENTER to confirm a change, or press MENU to cancel it,
- Press MENU to exit the menu or the submenu.

Some of the parameters available via menu can also be set directly during the measurement phase (like, for example, integration interval, measuring range, etc.) by use of the SELECT, UP, DOWN, LEFT, RIGHT and ENTER keys.

When you access the menus, the available memory will be displayed, as well as battery level, date and time.

See a detailed description of the menu items on page 35 and following pages.



## PRINT key

Press PRINT to send the screen page to the RS232 serial interface, in a printable format.

Data can be downloaded to a PC or sent to a serial printer as for example the HD40.1 (see page 67), directly connected to the sound level meter. In this last case, set the parameter MENU >> Instrument >> Input/Output >> Serial Device to: PRINTER, to get a printing format compatible with a portable 24 column printer.

Data downloading to a PC can be managed via a communication program, such as, i.e., Windows HyperTerminal.

**If the key is pressed and soon released, the single screen page is sent to the serial line; the letter “P” will be displayed. If the key is hold down, the continuous printing (Monitor) will be started and the letter “M” will be displayed:** to stop it, press PRINT again or press START/STOP/RESET to stop logging.



## PROG key

The PROG key is used to access the menu of the instrument programs. Use the UP and DOWN arrows to select the program; press SELECT to activate the selected program. These are the available programs:

- *Memory Navigator* (with the “Advanced Data Logger” option): allows accessing stored data and viewing them on the instrument display. It works both with single session data and with multiple ones. (See details on pag.42).
- *Electric Calibration*: single-frequency (1kHz) with electrical signal coming from the built-in sinusoidal reference generator. (See details on page 49).
- *Acoustic Calibration*: is used for the sound level meter tuning at 1kHz with an acoustic calibrator. (See details on page 51).
- *Diagnostic Check*: this program checks several instrument parameters: supply voltages, microphone polarization and sensitivity, type of preamplifier (see details on page 54).
- *Memory dump on MC*: this program allows to copy measurement data from internal sound level meter flash memory to external Secure Digital memory card (please see chapter on MC on page 71).

The selected program is performed upon pressing the SELECT key; some programs can be aborted at any time by pressing RIGHT on the keypad. When you access the programs, the available memory will be displayed, as well as battery level, date and time.



### PAUSE/CONTINUE key

The PAUSE key interrupts the calculation of integrated measurements (Leq, SEL, maximum or minimum levels, spectra, etc.), as well as recording. The instantaneous levels are still measured and displayed in the SLM screen. Press PAUSE/CONTINUE to start measuring again. The integrated parameters are cleared if you press RUN/STOP/RESET while in PAUSE (during a measurement session). The last seconds of integration can be excluded, from the calculation of integrated parameters shown on the SLM screen (for example, to eliminate the effect of an undesired noise), using the LEFT and RIGHT keys while in PAUSE. The maximum erasing interval is programmable from 5 seconds to 60 seconds via MENU >> Instrument >> Measurement.

If you press the RUN/STOP/RESET key while in pause during the replay of a recording (with the “Advanced Data Logger” option), the next stored data will be displayed. If you press the RUN/STOP/RESET key and hold it down, the replay will be performed in fast forward mode.



### REC key

If REC is pressed and hold down for at least 2 seconds, the displayed data are stored as a single report. You can also activate the automatic recording of the parameters displayed on the SLM screen, (see THE RECORD FUNCTION on page 30).

When the “Advanced Data Logger” option is installed, the REC key, combined with START/STOP/RESET, activates the data logging. **Starting from the STOP condition**, if you press REC and hold it down, then press START/STOP/RESET, the data logging of measured values is started. To stop logging, press START/STOP/RESET: registration number, date and time will be displayed. Press ENTER to confirm.



### RUN/STOP/RESET key

If you press RUN, while in stop, all the initial values of the integrated measurements like Leq, SEL, MAX/MIN levels will be first cleared (RESET) and then measurement starts. Pressing the key again (STOP), the measurements will be stopped. **If pressed while in pause, all integrated parameters will be cleared.**

During the replay of stored data (with the “Advanced Data Logger” option), if you press this key while in pause, the next data will be displayed; if you press it and hold it down, the replay will be executed in fast forward mode.



### **SELECT key**

The SELECT key activates the adjustment mode of displayed parameters by selecting them in sequence. Use the two arrows, UP and DOWN, to modify the values. When you have finished with the adjustments, wait a few seconds or press ENTER to confirm and quit the selection mode.



### **UP key**

The UP key selects a previous line in the menus or increases the selected parameter. Decreases the scale limits of the time profile and of the frequency spectra moving the graph upwards.



### **MODE key**

If “Advanced Data Logger” option is installed, the MODE key selects the different display modes of the instrument from *SLM* to *Time Profile*, *Probability Distribution*, *Cumulative Distribution*. All operating modes are active at the same time, even though not displayed: using the MODE key, you can select the display mode without affecting measurement.



### **LEFT key**

ZOOM 

The LEFT key selects the previous character in the active line of the menu. It jumps to a previous parameter during the selection of a measurement variable that needs the definition of more than one parameter (see SELECT).



### **ENTER key**

The ENTER key confirms the selected parameter. When setting parameters from the menu, to quit setting without saving a parameter, just press any key except **SELECT**, **ENTER** and the four ar-



**rows**, or press MENU. Factory setup is loaded into the sound level meter by turning it on while holding the **ENTER** key.

---



**RIGHT key**

ZOOM⊕

The RIGHT key selects the next character in the active line of the menu. It jumps to the next parameter during the selection of a measuring variable that needs the definition of more than one parameter (see SELECT).

---



**DOWN key**

The DOWN key selects the next line in the menus or decreases the selected parameter.

---



**CURSOR (Keypad)**

It activates the cursors in a graph. Press it repeatedly to activate in sequence: the first cursor L1, the second one L2 or both of them in “tracking” ( $\Delta L$ ). To disable the cursors, press the key again. Use the LEFT and RIGHT key of the keypad to move the flashing selected cursor over the graph. Relevant values are shown at the top of the display.

---



**LEFT (Keypad)**

The LEFT key moves leftwards the cursor or the two active cursors (flashing).

---



**RIGHT (Keypad)**

The RIGHT key moves rightwards the cursor or the two active cursors (flashing).

## ANNEX

### A1. HD2010UC MEASURING PARAMETERS

In the next paragraphs, are shown the acoustic parameters that can be displayed in numeric or graphic format, with the respective abbreviations used to identify them.

#### ACOUSTIC DESCRIPTORS (NUMERIC DISPLAY)

##### Instantaneous acoustic levels refreshed every 0.5s

###### Wideband

PARAMETER	ABBREV.	DEFINITION	WEIGH. FREQ.	WEIGH. TEMP.
L <sub>Xeq(Short)</sub>	LeqS dBX	Short equivalent level (0.5s)	X=Z, C, A	-
L <sub>XYp</sub>	LYp dBX	Sound pressure level (SPL) <sup>2</sup>	X=Z, C, A	Y=F, S, I
L <sub>Xpk</sub>	Lpk dBX	Instantaneous peak level	X=Z, C	-

##### Integrated acoustic levels

###### Wideband

PARAMETER	ABBREV.	DEFINITION	WEIGH. FREQ.	WEIGH. TEMP.
L <sub>Xeq</sub>	Leq dBX	Equivalent continuous level	X=Z, C, A	-
L <sub>XYmax</sub>	LYmx dBX	Sound pressure maximum level (SPL <sub>max</sub> )	X=Z, C, A	Y=F, S, I
L <sub>XYmin</sub>	LYmn dBX	Sound pressure minimum level (SPL <sub>min</sub> )	X=Z, C, A	Y=F, S, I
L <sub>Xpkmax</sub>	Lpkmx dBX	Peak maximum level	X=Z, C	-
L <sub>nn</sub>	Li, i=1÷4 nn%	nn% percentile with nn=1÷99 <sup>3</sup>	A	F

###### A weighting

PARAMETER	ABBREV.	DEFINITION	WEIGH. FREQ.	WEIGH. TEMP.
L <sub>AE</sub>	LE dBA	Exposure level throughout the measurement time (SEL)	A	-
Dose % <sub>A</sub>	Dose %	Dose percentage with programmable exchange rate, threshold level and criteria	A	-
Dose % <sub>A,d</sub>	Dose,d %	Daily estimated dose with programmable exchange rate, threshold level and criteria	A	-
LA <sub>Ieq</sub>	LeqI dBA	A weighted equivalent continuous level with Impulse time constant	A	I

###### Other

PARAMETER	ABBREV.	DEFINITION	WEIGH. FREQ.	WEIGH. TEMP.
Overload %	OL%	Percentage of the measurement time in which an overload occurs	-	-

<sup>2</sup> The maximum reached level every 0.5s is displayed.

<sup>3</sup> It is possible to program up to 4 different percentile levels.

## ACOUSTIC LEVELS (GRAPHIC DISPLAY)

### Time Profile (with “Advanced Data Logger” option)

#### Wideband Levels

PARAMETER	ABBREV.	DEFINITION	WEIGH. FREQ.	WEIGH. TEMP.
$L_{AFmax}$	LFmx dBA	Sound pressure maximum level ( $SPL_{max}$ ) ( $SPL_{max}$ )	A	F

#### Statistical Analysis <sup>4</sup>

PARAMETER	ABBREV.	DEFINITION	WEIGH. FREQ.	WEIGH. TEMP.
$L_{Xpk}$	LXpk	Peak level	X=Z, C	-
$L_{Xeq}$	LXeq	Equivalent level	X=Z, C, A	-
$L_{XFp}$	LXFp dBX	Sound pressure level with FAST time constant (SPL)	X=Z, C, A	F

## ACOUSTIC LEVELS THAT CAN BE STORED (WITH “ADVANCED DATA LOGGER” OPTION<sup>5</sup>)

### Measurement group acoustic Levels

All the levels that can be displayed, described above, related to the SLM and PROFILE.

### Report group acoustic levels

#### 5 selected parameters

PARAMETER	ABBREV.	DEFINITION	WEIGH. FREQ.	WEIGH. TEMP.
$L_{Xeq}$	Leq dBX	Equivalent continuous level	X=Z, C, A	
$L_{XYmax}$	LYmx dBX	Sound pressure maximum level ( $SPL_{max}$ )	X=Z, C, A	Y=F, S, I
$L_{XYmin}$	LYmn dBX	Sound pressure minimum level ( $SPL_{min}$ )	X=Z, C, A	Y=F, S, I
$L_{Xpk}$	Lpk dBX	Peak maximum level	X=Z, C	
SEL	LE dBA	Sound exposure level	A	
$L_{nn}$	$L_i, i=1\div 4$ nn%	nn% percentile with $nn=1\div 99^5$		
LAleq	LeqI dBA	A weighted equivalent continuous level with Impulse time constant	A	I

#### Statistical analysis on a selected parameter among the following

PARAMETER	ABBREV.	DEFINITION	WEIGH. FREQ.	WEIGH. TEMP.
$L_{Xeq}$	Leq dBX	Equivalent continuous level	X=Z, C, A	
$L_{XF}$	LFp dBX	Sound pressure maximum level ( $SPL_{max}$ )	X=Z, C, A	F

<sup>4</sup> If the option Advanced Analyser is not activated, the statistic analysis is calculated on the A weighted sound pressure with FAST time constant.

<sup>5</sup> It is possible to program up to 4 different percentile levels.

PARAMETER	ABBREV.	DEFINITION	WEIGH. FREQ.	WEIGH. TEMP.
$L_{Xpk}$	Lpk dBX	Sound pressure minimum level ( $SPL_{min}$ )	X=Z, C	

### Event group acoustic descriptors (with “Advanced Data Logger” option)

#### 5 selected parameters

PARAMETER	ABBREV.	DEFINITION	WEIGH. FREQ.	WEIGH. TEMP.
$L_{Xeq}$	Leq dBX	Equivalent continuous level	X=Z, C, A	
$L_{XYmax}$	LYmx dBX	Sound pressure maximum level ( $SPL_{max}$ )	X=Z, C, A	Y=F, S, I
$L_{XYmin}$	LYmn dBX	Sound pressure minimum level ( $SPL_{min}$ )	X=Z, C, A	Y=F, S, I
$L_{Xpk}$	Lpk dBX	Peak maximum level	X=Z, C	
SEL	LE dBA	Sound exposure level	A	
LA <sub>I</sub> eq	LeqI dBA	A weighted equivalent continuous level with Impulse time constant	A	I

#### Statistical analysis on a selected parameter

PARAMETER	ABBREV.	DEFINITION	WEIGH. FREQ.	WEIGH. TEMP.
$L_{Xeq}$	Leq dBX	Equivalent continuous level	X=Z, C, A	
$L_{XF}$	LFp dBX	Sound pressure level with FAST time constant ( $SPL_{FAST}$ )	X=Z, C, A	F
$L_{Xpk}$	Lpk dBX	Peak level	X=Z, C	

## A2. MEMORY CAPACITY DURING THE LOGGING FUNCTION

With the supplied 4 MB memory you can store up to 500 recordings.

Through the “Advanced Data Logger” option, the HD2010UC can automatically store data according to two different modes: continuous and automatic recording.

**The sound level meter storage capacity when in Continuous Recording mode is equal to 23 hours with the supplied memory of 4 MB.**

The table below gives the sound level meter storage capacity in Auto-Store mode, recording automatically, at the end of each period equal to the set integration time, the SLM screen parameters. The storage capacity is expressed as the time necessary to get the memory full.

Integration Interval	Capacity
5s	> 7 days
1m	> 85 days
5m	> 1 year

If the “Advanced Data Logger” is installed, the storage of *Reports* and *Events* is made by units (record) which are recorded corresponding to each interval (Menu >> Instrument >> Measurements >> Report Time ) or for each event. Each unit is made of one Header followed by the parameters enabled in the Menu >> Data Logger >> Report and >> Event. The following table explains the memory occupancy (in byte) for each block composing one unit (record).

Report or Event	Occupancy [bytes]
HEADER	7
PARAMETERS	10
STATISTIC	481

From the table it’s possible, for example, to calculate the memory occupancy for reports recording, every 10 minutes (Menu >> Instrument >> Measurements >> Report time >> 10 min), including the 5 PARAMETERS (Menu >> Data Logger >> Report >> Parameters >> ON) and STATISTICAL ANALYSIS (Menu >> Data Logger >> Report >> Statistics >> ON):

$$6 \cdot (7+10+481) = 2988 \text{ byte/hour} \gg \text{maximum duration} = 4 \text{ MB}/2988 \sim 58 \text{ days}$$

An additional 4MB expansion memory is available as an option doubling recording capacity.

### A3: THE SOUND

The sound is a variation of pressure audible by the human ear. Its propagation, starting from the source, occurs in the form of waves and is thus subject to all the phenomena typical of the waves, such as refraction and diffraction. The propagation speed depends on the medium and, in the air, at ambient temperature, it equals to about 344 m/s.

The ear sensitivity is quite high and able to perceive pressure variations equal to about 20  $\mu\text{Pa}$ , corresponding to 5 parts a milliard of the atmospheric pressure. This incredible sensitivity is joint to the capacity to bear pressure variations more than one million times higher. For convenience, it was decided to indicate the sound pressure level in decibel rather than pressure in Pascal, in order to reduce the numeric extension.

The decibel (dB symbol) is defined by:

$$dB = 20 \cdot \log_{10} \frac{X}{X_0}$$

where: X is the measured quantity.

$X_0$  is the reference value of the measurement (to which corresponds 0 dB).

In acoustics, the pressure is the measured quantity and the reference value corresponds to 20  $\mu\text{Pa}$ , the minimum audible pressure. Therefore the sound level corresponding to a 20  $\mu\text{Pa}$  (0.00002 Pa) pressure variation will be indicated as 0 dB. The sound level corresponding to a 20 Pa sound variation will be indicated with 120dB, a level at the limit of the pain threshold.

An increase by 10 times of the sound pressure corresponds to a level increase by 20 dB, while an increase by 100 times of pressure corresponds to an increase in level by 40 dB: the sound level increases by 20 dB against each increase of a factor 10 of the sound pressure. Similarly, the increase of the level is equal to 6 dB for each doubling of the sound pressure.

The use of decibels to indicate the sound level has, besides the evident advantage to reduce the measurement numeric range, the advantage of providing a good approximation of the audible perception that follows the sound pressure on a logarithmic scale.

Not all pressure variations are audible. When a pressure variation is due, for example, to climatic variations, it changes too slowly to be heard, but, if it is fast, like, for example, that produced by striking the drum or by bursting a balloon, it can be heard by the human ear and is consequently identified as a sound.

The number of pressure oscillations/second is called sound frequency and is measured in cycles per second or Hertz (Hz). The audible frequency range extends between approximately 20 Hz up to 20 kHz. Under 20 Hz we enter the infrasound field, while over 20 kHz we enter in that of ultrasounds.

Hearing sensitivity is not constant throughout the whole range of audio frequencies, but it shows a consistent loss at very low or high frequencies. Sensitivity is at its maximum in the range between 1 kHz ... 5 kHz. The variation of auditory sensitivity according to sound frequency also depends on the sound intensity. "Isophone" curves (equal loudness level contours), defined in ISO 226:2003 standard, are shown in the following graph and provide the sound pressure level giving the same audibility (loudness) at different frequencies. The dotted curve, named MAF (Minimum Audible Field) indicates the minimum audible threshold.

Music, voice and noises in general are usually distributed throughout a wide interval of frequencies. Borderline cases are: the "pure tone", a sound made up by a variation of pressure at a given frequency; and the "white noise": a sound uniformly distributed throughout all frequencies (it sounds like the TV audio rustling when it is not tuned in any station).

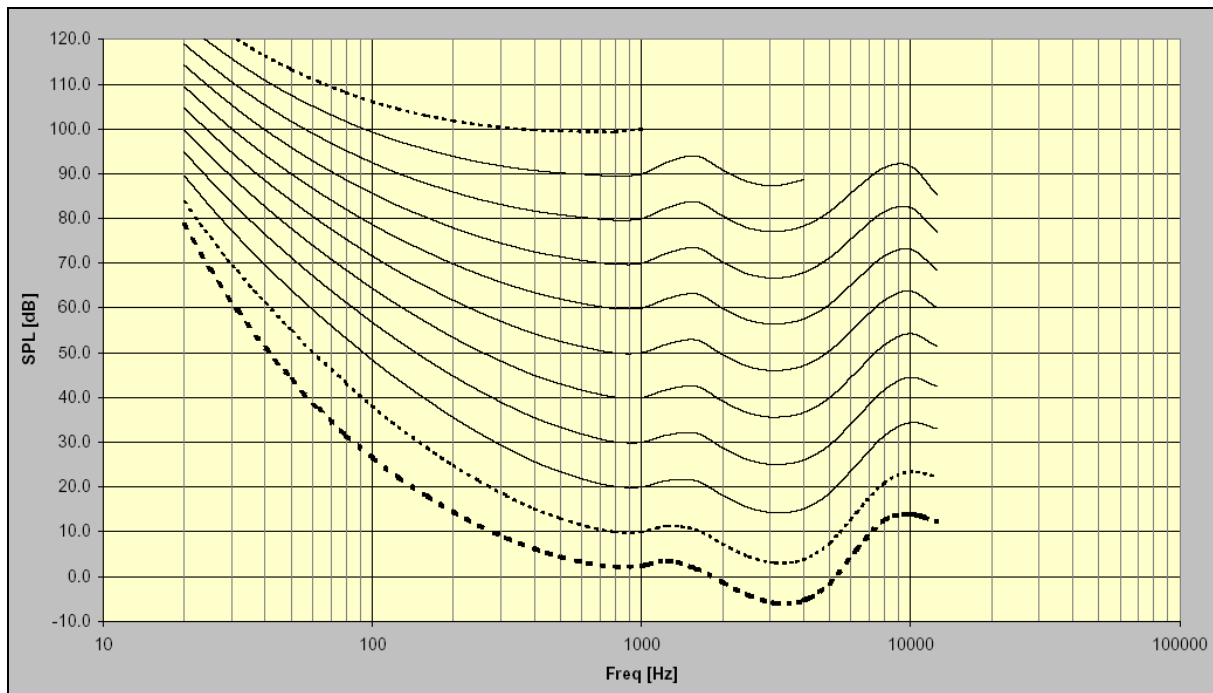

Noises characterized by the presence of a pure tone, are more bothering, at the same level, with respect to noises distributed over a wide interval of frequencies. The reason is to be found in the sound energy “concentration” in the ear mechanics.

Usually, the sound level is not static, but it changes with time. If the variation is very rapid, the ear cannot feel the real intensity. In case of sound pulses, we know that the ear has a reduced perception already for durations lower than 70 ms. For this reason, noises with an impulsive feature are usually considered, at the same level, more dangerous.

## A4: SOUND LEVEL METER

The sound level meter is the instrument that measures the sound level. Usually, it is made up by a microphone, the sound sensitive element, by an amplifier, by a signal processing unit and by a reading and data display unit.

The microphone converts the sound signal into a corresponding electrical signal. The sensitivity of microphones for level measurements does not depend on the sound signal frequency. The preference of the type of microphone is usually based on the condenser type that grants excellent features like accuracy, stability and reliability.

The amplifier is necessary to bring the electrical signal to a measurable amplitude and to strengthen the signal to allow cable transmission. The processing unit takes care of calculating all measuring parameters necessary to characterize a sound event.

## FREQUENCY WEIGHTING

If you have to assess the auditory impact of a noise source, you will have to make some corrections to the acoustic signal provided by the microphone in order to simulate the sound perception; this means that the microphone sensitivity will have to be adjusted to simulate the frequency response of the human ear. Two correction curves named “A weighting” and “C weighting” have been defined as international standard (IEC 60651, recently replaced by IEC 61672).

When the sound level is corrected by A weighting, it is referred to as  $L_{Ap}$ , and simulates the perception of low sound levels. When, on the contrary, the sound level is corrected by C weighting, it is referred to as  $L_{Cp}$ , and simulates the perception of high sound levels.

When there is no interest in sound perception, measurements are carried out using Z weighting (LIN for IEC 60651) that represents a constant response to all frequencies in the sound field.

## SPECTRAL ANALYSIS

The spectral analysis by bands is used to analyze in detail the features of a complex sound. For this analysis the range of audio frequencies (between 20 Hz and 20 kHz) is divided into bands, typically with a constant percentage bandwidth corresponding to an octave or to a third octave. The sound level is calculated for each band considering only the noise components with frequencies included within the band limits: for octave bands the upper limit always equal the double of the lower limit, while for the third octave bands, the upper limit equals 1.26 times the lower limit, so that an

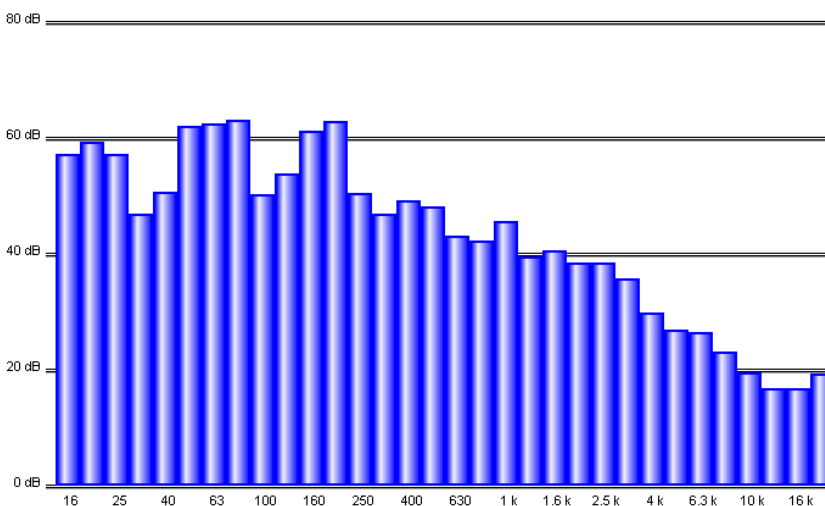

octave band is divided into three third octave bands. For example, the band centered at 1 kHz will consider the sounds between 707 Hz and 1414 Hz for octave and between 891 Hz and 1122 Hz for third octave bands. The analysis result is usually shown in a graph called “spectrogram” where the sound levels are represented in graphic format for each of the bands in which the sound spectrum has been divided.

The analysis result is usually shown in a graph called “spectro-



gram” where the sound levels are represented in graphic format for each of the bands in which the sound spectrum has been divided.

### TIME CONSTANTS AND EXPONENTIAL WEIGHTING

Further processing of the microphone signal is needed when fluctuating sound levels have to be measured. To evaluate a sound level varying with time, two type of instantaneous responses have been defined by international standards (IEC 60651/IEC 61672). One, named FAST, simulates the ear response, the other one, named SLOW, provides a sound level quite stable even in case of fluctuating noises.

The choice of the type of response of the level meter combines with the selection of frequency weighting to provide a wide spectrum of possible measuring parameters; for example, the A weighted sound level will be measured with a FAST time constant ( $L_{FAp}$ ) to simulate the auditory sensation. The FAST time constant is equal to 0.125s, while the SLOW constant equals 1s.

When measurements with a FAST time constant are carried out, the instantaneous sound level will be strongly affected by the pressure trend in the last octave of second, while it will not be affected by what happened more than one second before.

The sound level with a SLOW time constant will strongly depend, instead, on the trend of pressure in the last second, while it will not be affected by sound events occurred more than 10 seconds before. We can say that the sound level with a SLOW constant is approximately an average of the instantaneous levels of the last second.

### IMPULSIVE NOISES

If the sound has a short duration, it is called **impulsive**: i.e.: writing with a typing machine, the noise caused by a hammer or by a gun are classified as impulsive sounds. To assess their impact on the auditory apparatus, consider that the more the sound is short, the less the ear can hear it. For this reason, a time constant has been defined in the international standards (IEC 60651/IEC 61672), called IMPULSE, very fast (35ms) for increasing sound pressure levels and very slow (1.5s) for decreasing levels.

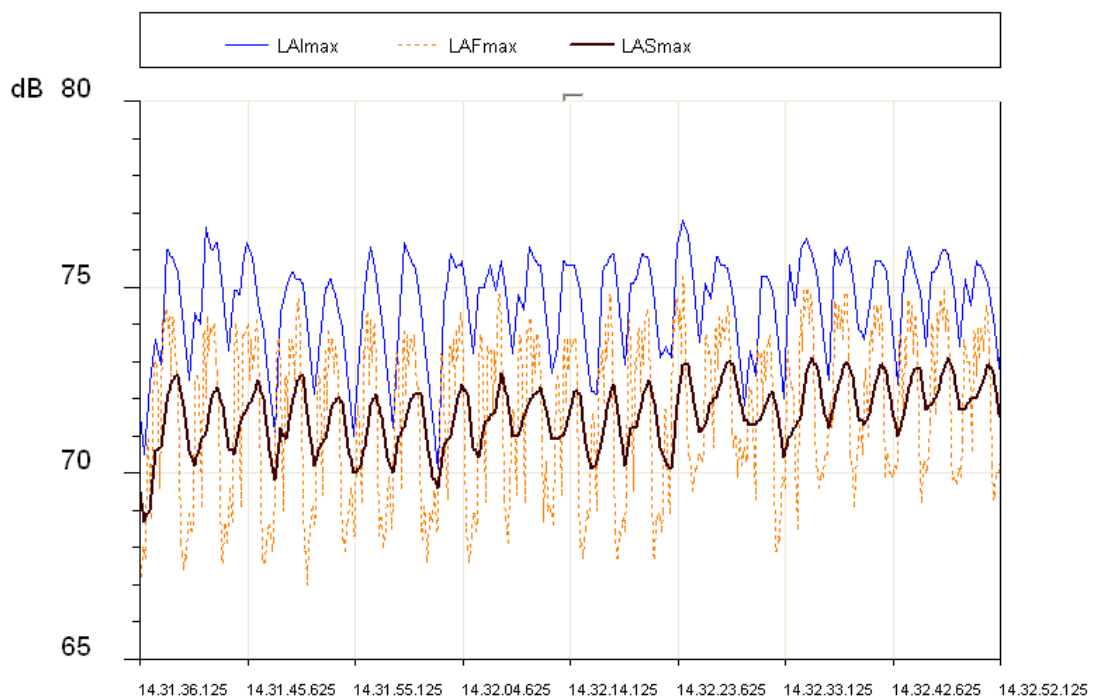

In case a sound source emits noises with a strong impulsive component, the level measured with the IMPULSE constant will be much higher than the SLOW level. The figure shows the sound level profile, measured simultaneously using the FAST, SLOW, and IMPULSE time constant by a surface mount machine.

The displayed levels are the maximum levels calculated on intervals equal to 1/8s. The most variable profile is the FAST profile (8dB) while the less variable is the SLOW one (3dB). The IMPULSE profile is systematically higher than FAST and SLOW, as it reflects the impulsive nature of the noise issued by the machine.

Impulsive sounds, independently on their spectrum, are more dangerous for the human ear, as the energy involved, in the short time-lapse in which they develop, does not allow the ear to take any defence. Therefore, the equivalent level being equal, a noise source containing impulsive components is generally penalized.

Unfortunately, while the ear sensitivity decreases according to the duration of noise, the risk of an auditory injury does not decrease. For this reason, sound level meters usually have a built-in circuit for the measurement of the acoustic signal peak value.

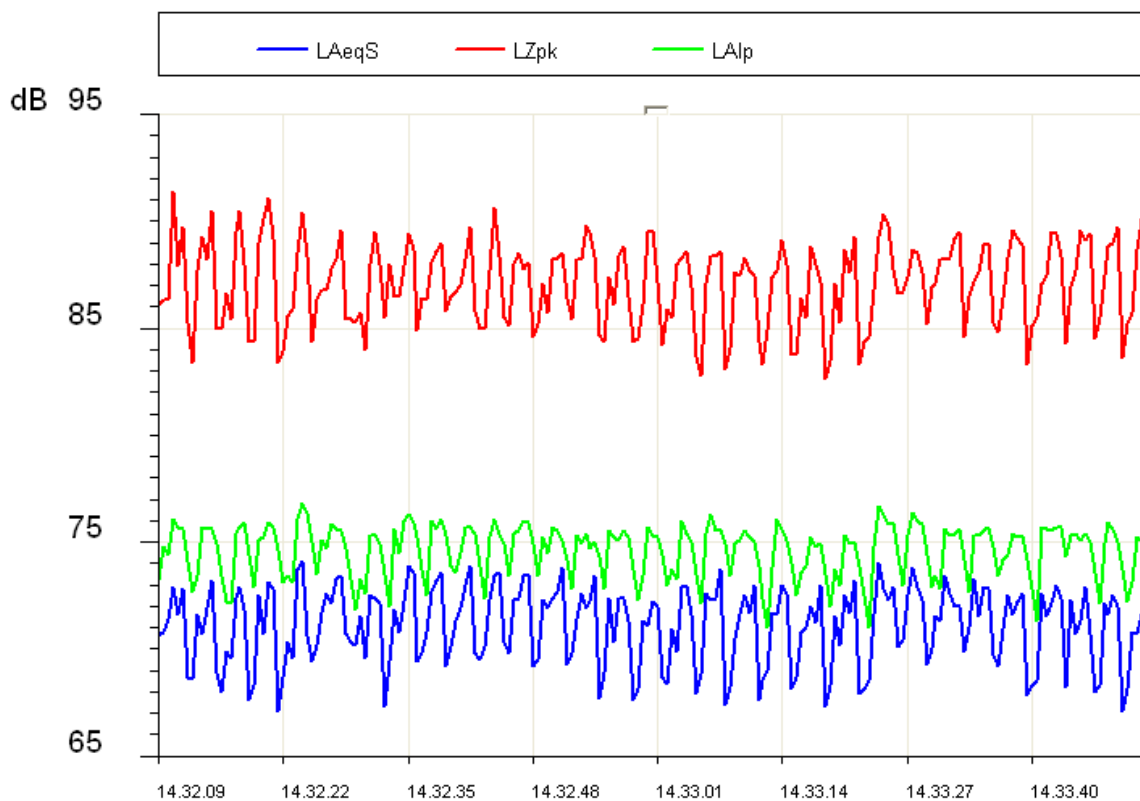

The non-weighted peak level and the IMPULSE level relevant to the surface mount machine are illustrated in the figure. As you can see, the peak level is at least 10 dB higher than the IMPULSE level. The parameter “PEAK”, referred to as  $L_{pk}$  has been defined in the international standards (IEC 60651/IEC 61672). It provides the peak level reached by the sound pressure in a given time interval. The response time of the peak level is very fast ( $<100\mu s$ ) and it is able to measure the sound level of very short sound events (for example, a gun shot) with sufficient accuracy.

#### EQUIVALENT SOUND PRESSURE LEVEL

The approximation obtained by considering the levels with FAST or SLOW time constant as short-term averages is quite rough. If the sound during its propagation transports energy, it is important to account for the duration of the sound event in order to interpret the energy content correctly.

This is particularly important in assessing the impact of the sound produced by machines or general pollution sources on the auditory apparatus. It is obvious that a strong noise generates a growing damage proportional to exposure. Evaluation of potentially harmful noise is therefore easy with constant level sounds.

If the sound varies in time you have to use a measurement parameter, defined in the international standards (IEC 60804, recently replaced by IEC 61672), called “equivalent level”, symbol  $L_{eq}$ . The equivalent level is defined as the constant level having the same energy content of the fluctuating level in the period being examined. The A weighted equivalent level ( $L_{Aeq}$ ) will be used to measure the energy content, and then the harmful potential, of a fluctuating noise source during a given period.

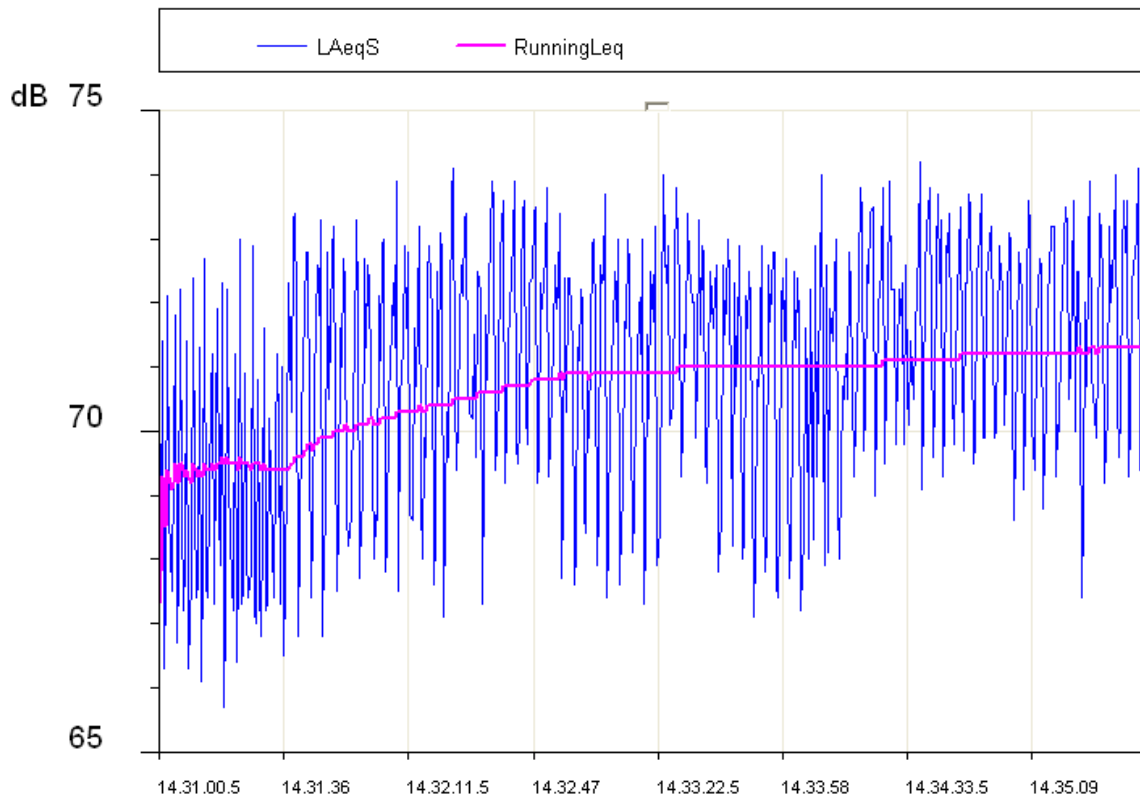

In the figure, the equivalent level profile is highlighted. It is stabilizing within few minutes to a level just above 71dBA.

Considering an intermittent source of noise (for example a train passing by), it is obvious that the equivalent level can give a measurement of the mean energy level after considering many passages.

If you wish to measure the energy content of a single passage, you need to use a different measurement parameter, the “Sound Exposure Level”, symbols  $SEL$  or  $L_E$  (IEC 60804/IEC 61672). The sound exposure level is defined as the constant sound level for 1 second that contains the same energy of the event being examined. By standardizing the SEL value (1 second), it is possible to compare sound events with different durations.

## STATISTICAL ANALYSIS

If you need to examine, from a statistical viewpoint, the distribution in time of the sound pressure level, you have to use the percentile levels. A percentile level, symbolized as  $L_x$  is defined as the sound level being exceeded by the X percentage during the total time. To calculate the percentile levels you first need to classify the sampled sound level according to regular intervals (usually 1/8s) in width classes, usually between 0.1dB and 2dB. At the end of the acquisition the probability

for each class is calculated by dividing the sampling frequency by the total number of samples. The result is the sound level distribution of probabilities shown below.



After this, the cumulative distribution is calculated. This is based on the sound level distribution of probabilities, beginning with a 100% probability for all lower classes with a value lower than the minimum measured level and for each class progressively subtracting the corresponding distribution probability of the level probabilities.

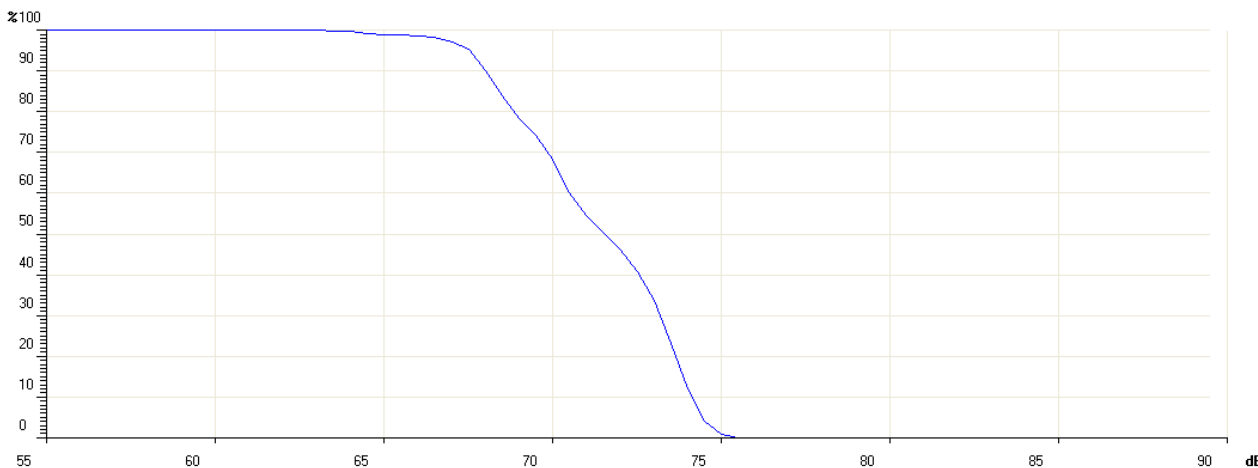

The cumulative probability will be null for levels higher than the maximum measured level. The percentile levels are calculated interpolating the cumulative distribution. For example, if from the analysis of the noise of a traffic road you detect that, the sound level (usually A weighted, examining the auditory impact), remains higher than 74dB half the time, the percentile level  $L_{50}$  is 74dB.

The integrating sound level meters directly supply the time integrated parameters, such as equivalent level and sound exposure level, in addition to maximum and minimum. On the other hand, the statistical analysis is a prerogative of statistical analyzers.

## NOISE DOSE

The measurement of the “Dose” of noise is used in the field of noise monitoring in a working environment, meant as a percentage fraction of a maximum daily exposure to noise. The organizations taking care of safety in working environments have defined some standards for the measurement of the noise dose considering the energy content of sound pressure and comparing it with a maximum daily equivalent level (over an 8-hour time interval) that is, in Italy, equal to 85 dBA (A weighted equivalent level) when no hearing protection is available.

ISO 1999 standard, considering only sound energy, sets out that an increase of 3 dB in the sound level halves the exposure time, to keep the dose equal. Italy applies ISO 1999 definition. Health corporations in other countries have adopted a different principle that takes into account the ear recovery times during pauses and allow to increase the level by 4 dB (DOD) or 5 dB (OSHA) before halving the exposure time.

## ACOUSTIC FIELD

Sensors and transducers in general are designed not to disturb the physical quantity to be measured. Exactly as a thermistor would limit to the minimum the temperature disturbance caused by its presence, also the microphone is designed not to alter heavily the acoustic field where it works. The alteration of acoustic field becomes important at frequencies corresponding to sound pressure wavelengths comparable to the microphone dimensions (diffraction phenomenon). For example, with 10 kHz, sound pressure wavelength equals about 3.4 cm, comparable with the dimensions of a typical microphone.

Essentially, there are two types of acoustic fields: the “free field” and the “diffuse field”. The field is defined “free” when the sound level decreases by 6 dB doubling the distance from the source. This condition is usually met with a good approximation at a distance from the source higher than its bigger dimension and, in any case, higher than the bigger wavelength of the generated noise.

The free field is significantly disturbed by the closeness of rigid walls, capable of “reflecting” sound levels comparable with those due to the acoustic pressure waves coming directly from the source.

The acoustic field in an environment where sound waves reflected by walls are dominant and, therefore, where the sound level is determined by sound pressure waves coming from all directions, is called “diffuse field”. While measurements in indoor environments are usually treated as diffuse field measurements, those outdoor are generally treated as free field measurements.

Since the microphone has dimensions comparable to the highest frequencies of the sound spectrum, it is designed to get an optimized response for a given acoustic field.

There are three types of microphone: for free field, diffused field and pressure.

The *microphone for free field* is designed to have a constant sensitivity at any sound field frequency for sound signals coming from the front side, making automatic adjustments to high frequencies to compensate the increase in pressure at the membrane level, due to its presence.

The *microphone for diffuse field* is instead designed to have a constant sensitivity at all frequencies for sound signals coming from all directions.

The *microphone for pressure measurements* is used for laboratory measurements even though, having a characteristic similar to that of a microphone for diffuse field, might also be used in reverberant fields.

When a diffuse field microphone is used in free field, it usually provides precise values when it is oriented at 70° - 80° compared to the sound source. If it is pointed to the source direction, it provides too high values, mainly at high frequency. Vice-versa, a microphone optimized for the free field will provide too low values when measuring in reverberant fields and in all cases in which it will not be oriented towards the sound source.

Modern sound level meters, like HD2010UC, apply corrections that can modify microphone responses according to the acoustic field in which they are used. In this way you can, for example, make measurements in indoor environments, in presence of multiple sound sources and anyway in a reverberant field, with a microphone optimized for free field, by activating the correction specific for random incidence. Applying this adjustment, the free field microphone will give a response similar to that of a diffuse field microphone.

## ENVIRONMENTAL INFLUENCE

### Temperature

Sound level meters are designed to work at temperatures included in the range:  $-10^{\circ}\text{C} \dots +50^{\circ}\text{C}$ . Most accurate sound level meters can have adjustment circuits for thermal drifts aiming to reduce at minimum the measuring error over the whole temperature range. It is suggested, however, to avoid sudden variations that might cause condensation. Furthermore, be sure that the instrument is in thermal equilibrium before carrying out a measurement or a calibration (just wait an hour after temperature has changed).

### Humidity

The HD2010UC sound level meter and the microphone are not affected by relative humidity up to 90%. However, protect the microphone from rain and snow and keep it clean. In case of bad weather, it is suggested to use a windshield and, in case of use in very humid environments, the proper microphone dehumidifier should be applied.

### Pressure

Microphone sensitivity depends on atmospheric pressure. Sensitivity increases as pressure decreases and the change of sensitivity for the HD2010UC with the UC52 microphone measured at 250 Hz is always lower than  $\pm 0.3 \text{ dB/kPa}$  in the range 85 kPa  $\div$  108 kPa as required by IEC 61672 for Class 1 sound level meters. Sensitivity drift with ambient pressure is usually worst at high frequencies, even if the sensitivity maximum difference in the range 85 kPa  $\div$  108 kPa remains within  $\pm 0.5 \text{ dB}$  over the whole sound spectrum.

### Wind

To reduce wind disturbance as much as possible, it is suggested to use the proper windshield, consisting of a polyurethane porous globe to be placed on the microphone.

This useful accessory protects also from dust, dirt, rain and snow. The presence of a windshield slightly alters the microphone frequency response and more accurate sound level meters are provided with a correction curve to compensate this effect.

### Vibrations

Even though microphone and sound level meter cannot be easily affected by vibrations, it is better to isolate both instrument and microphone from strong vibrations.

### Magnetic Fields

The influence of electrostatic and magnetic fields on the sound level meter is negligible.

## PRECAUTIONS AND GENERAL RULES OF USE

- Ensure that ambient conditions fit the use of a sound level meter. Take care that the instrument has reached thermal equilibrium, that there is no condensation on metal walls and that temperature, relative humidity and pressure are within the limits specified by the manufacturer. The use

of the sound level meter in conditions of high humidity with consequent condensation, can cause damages.

- Check the battery level of both sound level meter and calibrator.
- Check that the sound level meter is calibrated by measuring the calibrator reference sound level. This inspection has to be repeated at the end of measurements to assure the sound level meter stability.
- Use the windshield, when necessary. The shield grants a good protection against shocks. Its use is suggested also indoor, above all in presence of machines with mechanical parts in movement. When available, activate the proper adjustment on the sound level meter, to compensate the shield effect on the microphone frequency response.
- Determine the type of acoustic field where you have to operate and eventually apply the corrections that the sound level meter provides. Consider the measuring environment, the kind of sound source and the position in which measurements are carried out.
- Position the microphone according to the type of acoustic field considering also the correction made by the sound level meter, if any.
- The choice of frequency weighting and of time constant usually depends on the standard used to carry out measurements.
- Consider that the presence of an operator during measurement alters the sound field: thus keep the instrument as far as you can from your body. For better accuracy, position the sound level meter on the tripod, especially for spectral analyses. Best results are obtained if only the preamplifier is mounted on the tripod and the extension cable is used to connect it to the instrument.

## CLASSIFICATION OF ACOUSTIC SIGNALS

Acoustic signals can be classified according to the possible analysis techniques. First of all we can divide the acoustic signals into two classes: stationary and non-stationary signals.

**Stationary Signals:** these are the signals which average values (mean value, equivalent value, etc.) do not depend on time.

Among the stationary signals there are the deterministic and the random signals:

**Deterministic Stationary Signals:** these are the stationary acoustic signals that can be described with a function of time that is as a sum of sinusoidal signals. These signals are periodical if the sinusoidal components are all multiples of a main frequency. They are also called “quasi periodical”.

**Random Stationary Signals:** these are the signals that can be described only in statistical terms.

Among the non-stationary signals can be identified continuous and transitory signals:

**Continuous Non-stationary Signals:** these are the signals that never have a null value.

**Transitory Non-stationary Signals:** these are the signals that have a non-null value only in determined time intervals.

*Stationary signals* can be analyzed over different time intervals obtaining comparable and repeatable mean levels. A frequency analysis can be made with a sequential spectrum analyzer, measuring the sound level band by band until the interested spectrum is covered. Spectra of periodical stationary signals will be striped, which means that they will have non-null levels only in the bands with characteristic nominal frequencies. Random stationary signals will have instead a continuous spectrum.

An example of deterministic stationary signals could be a note or a chord played by a musical instrument, while for random stationary signals the example might concern car traffic noise or air-conditioning noises.

*Non-stationary signals* have sound levels depending both on the period of measurement and on integration time. The time taken for the analysis is critical for this type of acoustic signals and the frequency analysis has to measure all levels in every band of the spectrum at the same time. The analyzer suitable to this kind of measurement is called to operate in “real time”. Among the non-stationary signals we can include talking or impulsive signals, such as a balloon burst.

The calculation of integrated mean values over a given time interval might be used in spectral analysis of deterministic stationary signals, according to the signal main frequency. If the average time is at least 3 times higher than the acoustic signal main period, level oscillations are considered negligible.

To get stable and repeatable levels, the integration time can be adjusted. In this case, consider that the uncertainty in determining sound levels will depend not only on the integration time, but also on the bandwidth of the filter being examined. In the case of the white noise, the following formula provides the uncertainty due to the statistical error.

$$u_s = \frac{4.34}{\sqrt{B \cdot T_{\text{int}}}}$$

Some acoustic signals can be analyzed in statistical terms. The statistical analysis provides information complementary to that provided by the calculation of the equivalent level for signals strongly time dependent. Actually, signals with completely different time evolutions, and, consequently, with an impact completely different on the auditory apparatus, can have the same equivalent level. For example, in the analysis of the noise made by car traffic it is convenient to measure the so called “statistical levels” (or “percentile levels”) providing a description of noises fluctuating in time.

The statistical levels provide the sound level exceeded by a certain percentage of the measuring time, and are represented with the symbol  $L_x$ , where  $x$  is the percentage value; for example  $L_{10}$  gives the sound level exceeded in the 10% of the measuring time. For the calculation of the percentile levels, the analyzer makes a sampling of the  $L_p$  sound level, with FAST time constant and A frequency weighting, at a frequency usually equal to 10 Hz.

Sound levels measured in this way are classified over the whole measurement range according to given amplitude intervals, usually a fraction of decibel, called classes. When starting the measurement all classes will have a null number of samples, while at the end of measurements, the classes will contain a number of samples depending on the rate with which a sound level has been measured inside the respective interval.

At the end of the measurement time, the distribution of probabilities will be first calculated, dividing the content of any class by the total number of samples and multiplying the result by 100; then the cumulative distribution of probabilities will be calculated, having a value of 100% for levels lower than the first class containing at least a sample and taking lower values down to zero for levels higher than the last class containing samples.

From the definition of the statistical levels it is evident that  $L_1$  will be very near to the maximum measured level, while  $L_{99}$  will be very near to the minimum measured level. Therefore, while levels  $L_1$ ,  $L_5$  and  $L_{10}$  are representative of the peaks of the acoustic signal,  $L_{90}$ ,  $L_{95}$  and  $L_{99}$  are representative of the background noise.

Other parameters characterizing the sound level have been derived from the statistical levels. For example, in the measurement of vehicle traffic noise, the “Traffic Noise Index” has been defined as:

$$\text{TNI} = 4 \cdot (L_{10} - L_{90}) + L_{\text{eq}}$$

That provides higher values in the case of a sound level strongly fluctuating and thus characterized by a bigger difference between  $L_{10}$  and  $L_{90}$ .



## A5. MICROPHONE OUTDOOR PROTECTION HD WME - ASSEMBLY, DISASSEMBLY AND MAINTENANCE

Are given below operating instructions to disassembly, assembly and periodic maintenance of HD WME outdoor protection unit.

### A5.1 - Disassembly

To completely disassemble the unit, a 1.5mm male hex key and a 14mm wrench are needed. To separate all components of the unit, proceed as follows; to extract the group-preamplifier microphone capsule to calibrate, start from step 3:

1. Remove the anti-bird spike by loosening the three hex head screws at the base of the windscreen.

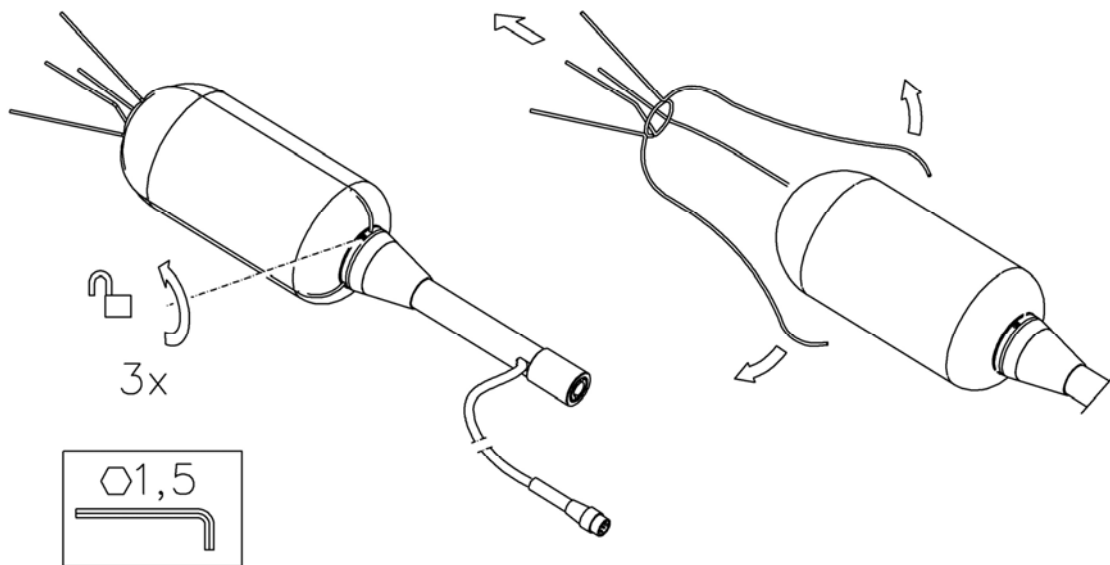

2. Pull up the windscreen HDSAV3 and the rain protection.

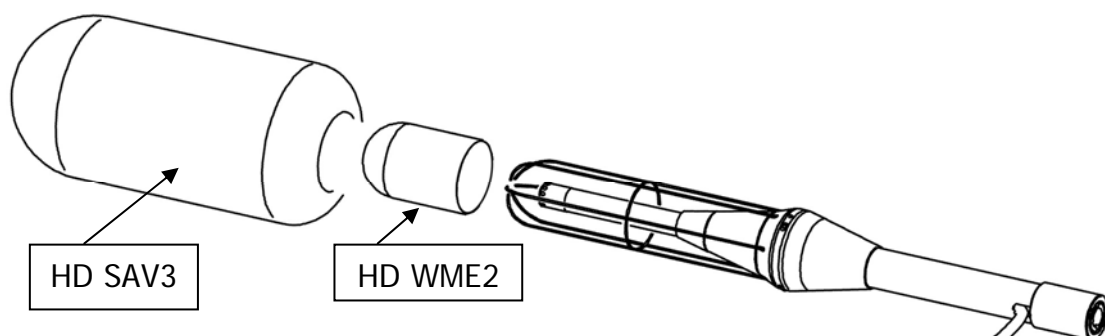

3. Unscrew the terminal placed at the lower end of the stem (A).

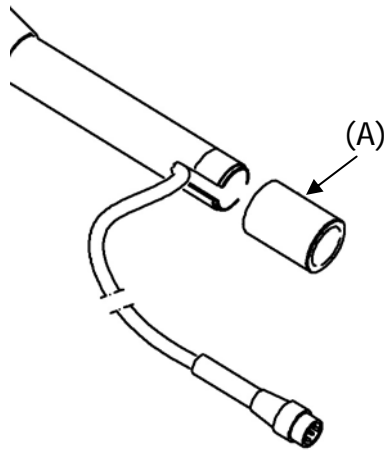

4. Unscrew the stem (B) and disconnect the cable connected to the preamplifier.

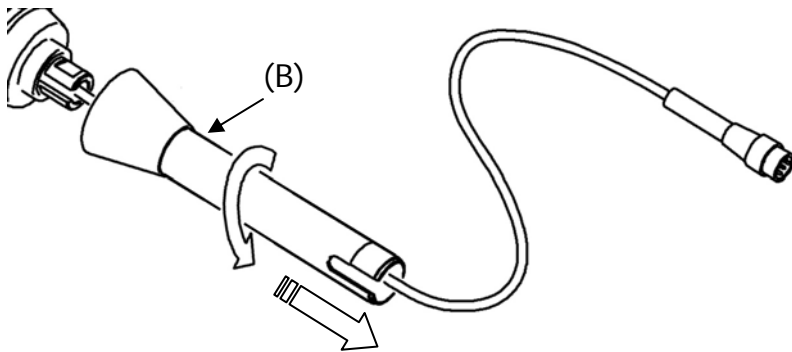

5. Unscrew the lock nut of the preamplifier (C) using, if required, a 14mm wrench. Be careful not to twist the preamplifier cable.

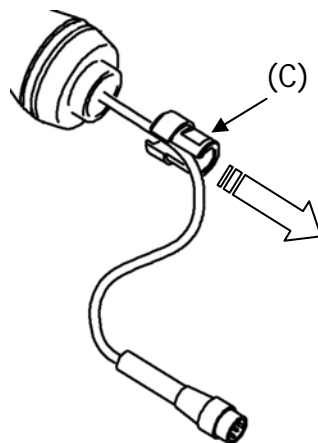

6. Remove the preamplifier (D) by pulling it slowly down. At this point the microphone is accessible and you can proceed with calibration.

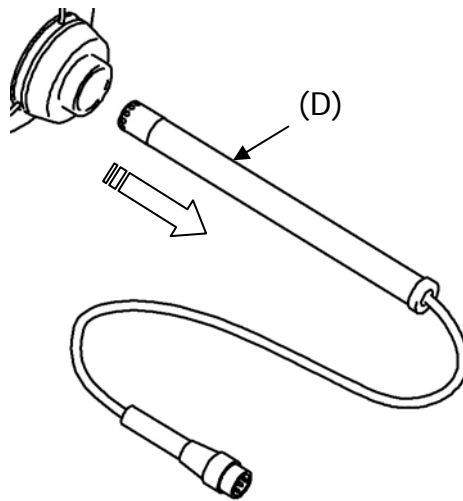

For details on calibration, see the specific chapter at page 40.

7. For assembly of HD WME protection, proceed as described in the next paragraph.

### **A5.2 - Assembly**

To assemble the unit, a 1.5mm male hex key and a 14mm wrench are needed.

To assemble completely the protection, start from step 1. If you need only to assemble the preamplifier with the microphone after calibration, from step 4.

1. Fit the rain shield HD WME2 on the metal grid support.

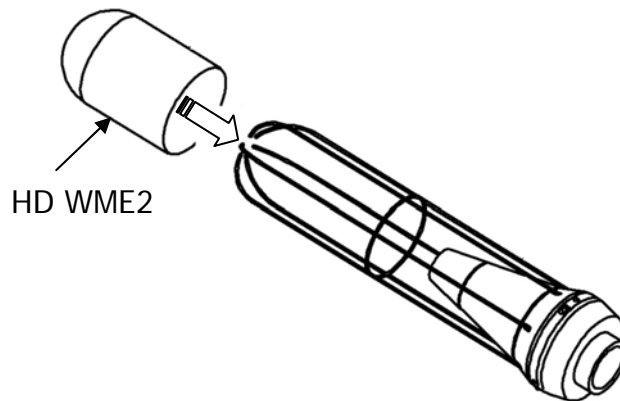

2. Insert the wind screen HD SAV3.

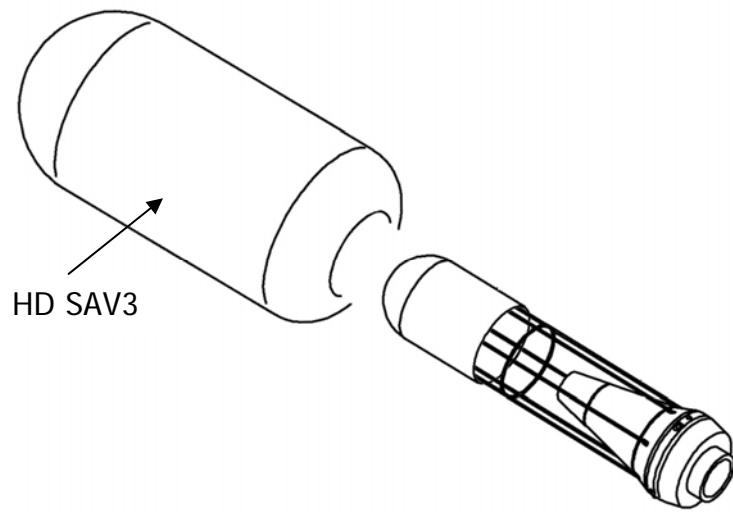

3. Apply the anti-bird spike and secure it using the three hex head screws located on the support at the base of the windscreen.

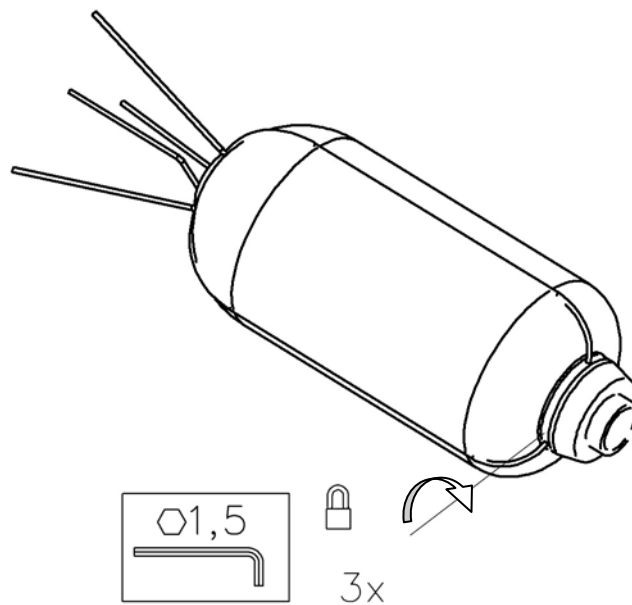

4. Insert the preamplifier (A) into the support pushing slowly upward until it's limit position.

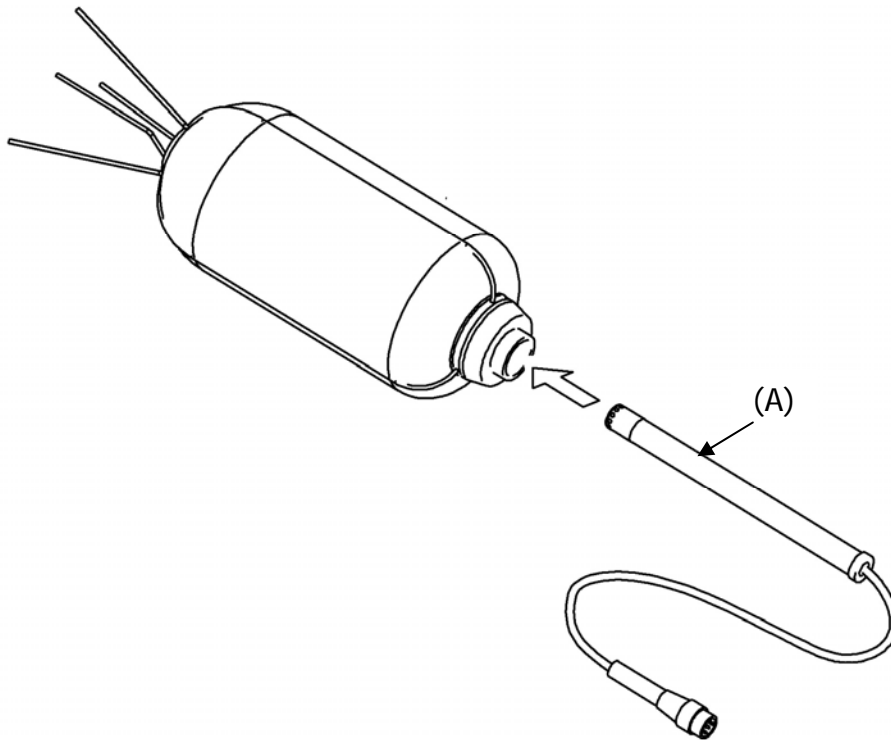

5. Screw the gland (B) using, if necessary, a 14mm wrench. Be careful not to twist the preamplifier cable.

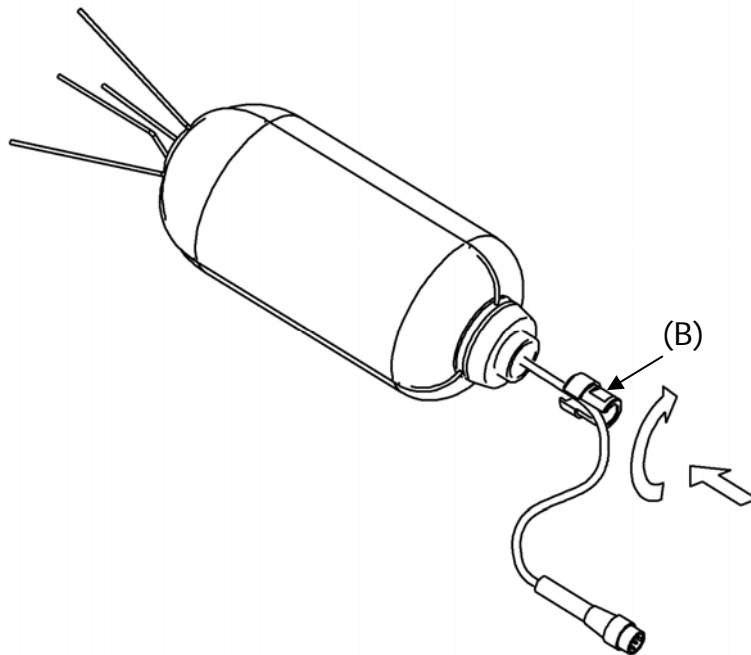

6. Insert the cable connected to the preamplifier through the system (C) and screw the stem to the support.

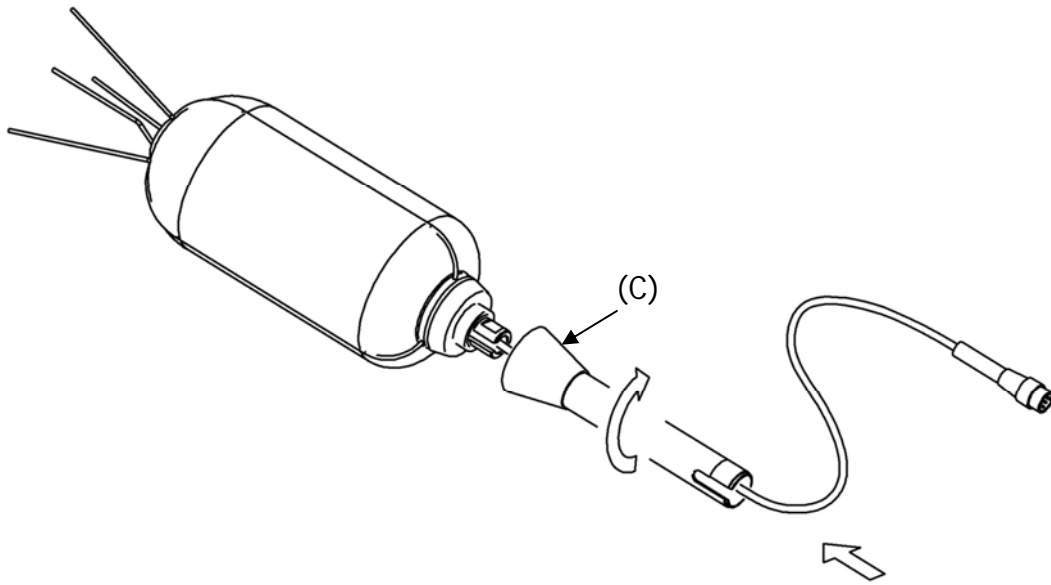

7. Screw the terminal placed at the lower end of the stem (D) releasing the cable laterally.

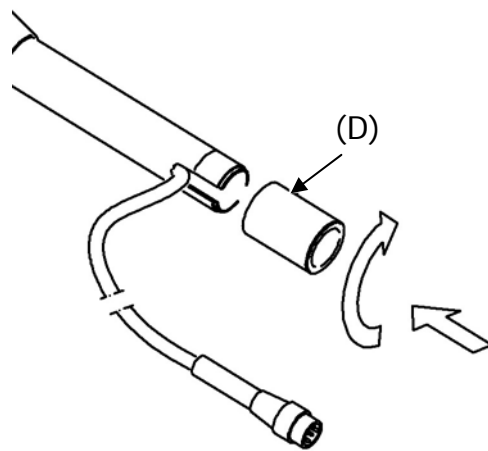

8. To secure the outdoor protection you can use the threaded end (D) or you can apply the fitting (E) on the tripod. The terminal (E) has two threads , 1/2 “ and 1/4”.

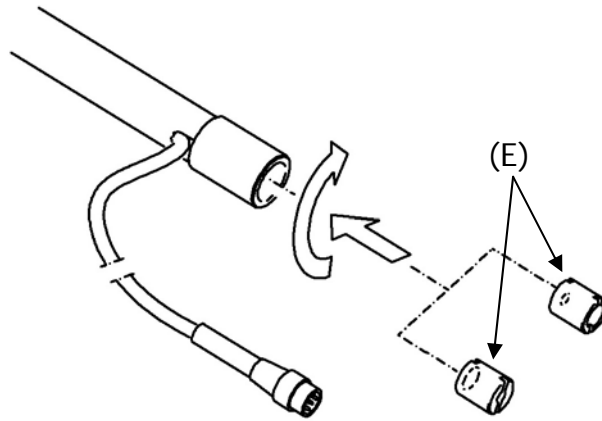

## A6: DEFINITIONS

**Frequency:** is the number of oscillations per second, expressed in Hertz (Hz).

**Wave Length:** is the distance between two adjacent maximum values of pressure, expressed in meters (m).

**Period:** is the interval of time necessary to make a complete oscillation, expressed in seconds (s).

**Sound Propagation Speed:** is the distance covered by the sound wave front in the unit of time, expressed in meters/second (m/s). The propagation speed depends on the medium and, in the air, at ambient temperature, it equals to about 344 m/s.

**Decibel:** a decibel (symbol: dB) is defined by:

$$dB = 20 \cdot \log_{10} \frac{X}{X_0}$$

where: X is the measured quantity.

X<sub>0</sub> is the reference value of the measurement itself (to which correspond 0 dB).

**Sound Pressure:** the sound pressure is the value of the change of atmospheric pressure caused by acoustic perturbations, expressed in Pascal.

**Reference Sound Pressure:** sound pressure taken as reference for the calculation of the pressure level; it equals  $20 \cdot 10^{-6}$  Pascal and corresponds to the average human audibility threshold at a frequency of 1 kHz.

**Effective Value:** sound pressure effective value ( $p_{rms}$ ) is the value of constant pressure that is energetically equivalent to the instantaneous value ( $p$ ) in a given time interval T.

$$p_{rms} = \sqrt{\frac{1}{T} \int_{t_1}^{t_2} p^2(t) dt}$$

where: T =  $t_2 - t_1$  is the considered time interval.

$p^2(t)$  is the sound pressure squared at time t in  $t_1 \div t_2$  interval.

rms means “ROOT MEAN SQUARE”, that is square root of the average of squared values.

Sound pressure effective value is expressed in Pa and takes importance in sound measurement since the value is directly connected to the quantity of energy contained in the sound signal.

**Crest Factor:** is the ratio between the maximum and the effective value of a quantity, measured in a given time interval with reference to the arithmetic average value.

**Sound Pressure Level:** is defined by the expression:

$$L_p = 20 \cdot \log_{10} \frac{p_{rms}}{p_0}$$

where:  $p_{rms}$  = pressure effective value.

$p_0$  = reference sound pressure.

$L_p$  sound pressure level (also referred to as SPL) is expressed in dB.



**Sound Pressure Level with Frequency Weighting:** The sound pressure level can be weighted in frequency applying a filter that changes in a predetermined way the signal spectral structure. Acoustic standard filters are referred to as A and C.

**Sound Pressure Level with Time Weighting:** The sound pressure level can be exponentially weighted over the time with a given time constant. It is defined by the expression:

$$L_{Yp} = 10 \cdot \log_{10} \left( \frac{1}{\tau} \int_{-\infty}^t \frac{p^2(\xi) \cdot e^{-\frac{t-\xi}{\tau}}}{p_0^2} d\xi \right)$$

where:  $\tau$  = time constant expressed in seconds.  
 $Y$  = symbol associated to the applied time constant.  
 $\xi$  = fictitious variable for the integration over elapsed time up to  $t$  measurement instant.  
 $p^2(\xi)$  = the instantaneous squared pressure.  
 $p_0^2$  = the square of reference pressure.

The sound pressure level can be weighted over the time with two standard time constants: FAST (F) and SLOW (S), corresponding to 0.125s and 1s, respectively. A third time weighting called IMPULSE (I) has been defined for the identification of impulsive components, presenting a time constant for increasing levels equal to 35ms, while for decreasing levels it equals 1.5s.

The sound pressure level can be weighted both in frequency and in time. For example,  $L_{AFp}$  will indicate a frequency weighted level with A filter and with FAST time constant.

**Sound Pressure Peak Level:** referred to as  $L_{pk}$ , it equals the absolute value of the maximum sound pressure in a given time interval, expressed in decibel. Sound pressure peak level can be frequency weighted.

**Continuous Equivalent Sound Pressure Level:** referred to as  $L_{eq}$ , it is defined over a  $T$  time interval as:

$$L_{eq,T} = 10 \cdot \log_{10} \left( \frac{1}{T} \int_{t-T}^t \frac{p^2(\xi)}{p_0^2} d\xi \right)$$

where:  $T = t_2 - t_1$  is the time interval under examination.  
 $\xi$  = fictitious variable for the integration over elapsed time up to  $t$  measurement instant.  
 $p^2(\xi)$  = the instantaneous squared pressure.  
 $p_0^2$  = the square of reference pressure.

The equivalent sound pressure level can be frequency weighted. For example,  $L_{Aeq,T}$  will give the equivalent sound pressure level over  $T$  interval, frequency weighted with A filter.

Total  $L_{eq}$  calculated by measuring partial  $L_{eq}$

If you need to get the total  $L_{eq}$  after measuring partial  $L_{eq}$ , you can use the formula:

$$L_{eq} = 10 \cdot \log_{10} \sum_1^n \frac{T_i}{T} \cdot 10^{\frac{L_{eq,i}}{10}}$$

where  $T = \sum_i^n T_i$

Example:

Let's suppose we measured:

$L_{eq,1} = 80$  dB over 1 h.

$L_{eq,2} = 90$  dB over 2 h.

$L_{eq,3} = 50$  dB over 5 h.

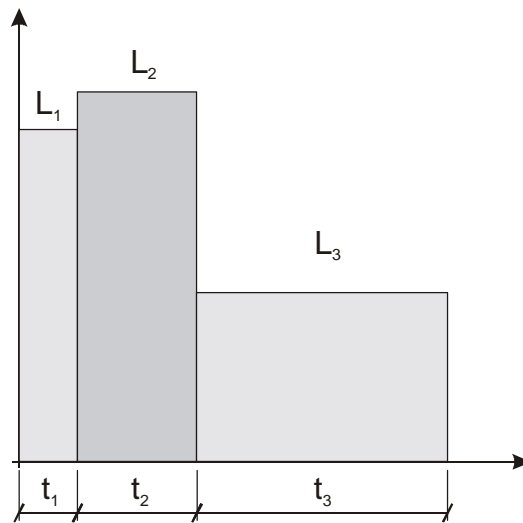

$$L_{eq,T} = 10 \cdot \log_{10} \left[ \frac{T_1 \cdot 10^{\frac{L_{eq,1}}{10}} + T_2 \cdot 10^{\frac{L_{eq,2}}{10}} + T_3 \cdot 10^{\frac{L_{eq,3}}{10}}}{T_1 + T_2 + T_3} \right]$$

$L_{eq,1}, L_{eq,2}, L_{eq,3}$  partial equivalent levels.

$T_1, T_2, T_3$  integration times of partial equivalent levels.

$L_{eq,T}$  total equivalent level.

In the example:  $T = 1 \text{ h} + 2 \text{ h} + 5 \text{ h} = 8 \text{ h}$ .

The result is::

$$L_{eq,T} = 10 \cdot \log_{10} \left[ \frac{1 \cdot 10^8 + 2 \cdot 10^9 + 5 \cdot 10^5}{8} \right] = 84.2 \text{ dB}$$

**Sound Exposure Level:** represented by the  $L_E$  symbol (or SEL), it is defined over a given  $t_1 \div t_2$  time interval like:

$$L_{E,T} = 10 \cdot \log_{10} \left( \int_{t_1}^{t_2} \frac{p^2(t)}{p_0^2 \cdot T} dt \right) = L_{eq,T} + 10 \cdot \log_{10} \frac{T}{T_0}$$

where:  $T = t_2 - t_1$  is the time interval under examination.  
 $p^2(t)$  = the square of instantaneous pressure.  
 $p_0^2$  = the square of reference pressure.  
 $L_{eq,T}$  = continuous equivalent sound pressure level over “T” interval  
 $T_0 = 1s$ .

The level of  $L_E$  sound exposure is expressed in decibel and can be frequency weighted. For example,  $L_{AE}$  will indicate the level of frequency weighted sound exposure with A filter.

**Dose**

In the field of environmental noise monitoring, preventing auditory injuries, the measurement of the noise “Dose” is used. It is meant as a percentage fraction of a daily maximum exposure to noise:

$$D(Q) = \frac{100}{T_c} \cdot \int_0^T 10^{\frac{L-L_c}{q}} dt$$

- D(Q) = exposure percentage for an Exchange Rate equal to Q.
- $T_c$  = daily exposure time (usually 8 hours).
- T = measurement time.
- L = sound pressure level when it is higher than the Threshold Level, and  $-\infty$  otherwise.
- $L_c$  = Criterion Level for a daily exposure corresponding to 100% of the dose.
- Q = Exchange Rate.
- q = parameter independent of the exchange rate and equal to:
  - 10 for Q = 3 dB
  - $5/\log 2$  for Q = 5 dB
  - $4/\log 2$  for Q = 4 dB

# TABLE OF CONTENTS

<b>CONNECTOR FUNCTION</b> .....	<b>4</b>
<b>INTRODUCTION</b> .....	<b>6</b>
<i>HD2010UC Block Diagrams</i> .....	9
<i>The Microphone</i> .....	10
<i>The Outdoor Microphone Unit HD WME</i> .....	10
<i>The Preamplifier</i> .....	11
<i>The Instrument</i> .....	12
<b>DESCRIPTION OF DISPLAY MODES</b> .....	<b>13</b>
SLM (SOUND LEVEL METER) .....	15
<i>Display Description</i> .....	15
<i>Selecting Parameters</i> .....	16
<i>Back-Erase Function (data exclusion)</i> .....	16
TIME PROFILE MODE (REQUIRES THE “ADVANCED DATA LOGGER” OPTION).....	18
<i>Display Description</i> .....	18
<i>Using the Cursors</i> .....	19
STATISTICAL GRAPHS .....	20
<i>Level distribution of probabilities</i> .....	21
<i>Percentile Levels Graph</i> .....	22
EVENT TRIGGER FUNCTION .....	24
<b>DESCRIPTION OF THE DIFFERENT INTEGRATION MODES</b> .....	<b>26</b>
SINGLE INTEGRATION .....	27
MULTIPLE INTEGRATION (REQUIRES THE “ADVANCED DATA LOGGER” OPTION) .....	28
<b>PRINT AND MONITOR FUNCTIONS</b> .....	<b>29</b>
<b>THE RECORD FUNCTION</b> .....	<b>30</b>
MANUAL AND AUTOMATIC SINGLE RECORDING .....	30
CONTINUOUS RECORDING.....	31
CONTINUOUS RECORDING OF REPORT AND EVENTS GROUPS.....	32
<b>DESCRIPTION OF THE MENU FUNCTIONS</b> .....	<b>35</b>
INSTRUMENT.....	36
<i>Identification</i> .....	36
<i>System</i> .....	36
<i>Input/Output</i> .....	37
<i>Measurements</i> .....	37
<i>Sound Level Meter</i> .....	38
STATISTICAL ANALYZER .....	38
TRIGGER .....	39
RECORDING .....	39
<i>Measurements</i> .....	39
<i>Report</i> .....	40
<i>Event</i> .....	40
CALIBRATION .....	40
SEQUENCER .....	41
<b>PROGRAMS</b> .....	<b>42</b>
NAVIGATOR.....	42
CALIBRATION .....	45
<i>Periodic calibration</i> .....	47
<i>Electric calibration</i> .....	49
<i>Acoustic Calibration</i> .....	51
<i>Microphone replacement</i> .....	54
<i>Diagnostic check</i> .....	54
<b>FIRMWARE UPGRADE</b> .....	<b>54</b>

<b>OPTIONS UPGRADE.....</b>	<b>54</b>
<b>BATTERY SYMBOL AND BATTERY REPLACEMENT.....</b>	<b>55</b>
<b>INSTRUMENT STORAGE.....</b>	<b>56</b>
<b>SERIAL INTERFACE.....</b>	<b>57</b>
COMMUNICATION PROTOCOL.....	59
SET GROUP (SETUP).....	60
KEY GROUP.....	63
GROUP (STATUS).....	63
DMP GROUP (DUMP).....	65
CONNECTION TO A MODEM.....	66
CONNECTION TO A PRINTER.....	67
CONNECTION TO A PC WITH USB INTERFACE.....	68
<i>Note for installation</i> .....	69
<i>Verification of proper driver installation</i> .....	69
<b>HD2010/MC MEMORY CARD READER.....</b>	<b>71</b>
DESCRIPTION OF THE INTERFACE FOR MEMORY CARD HD2010/MC.....	71
PREPARATION OF A NEW MEMORY CARD.....	71
CONNECTION OF HD2010/MC TO THE SOUND LEVEL METER AND USE OF THE MEMORY CARD.....	72
READING DATA DIRECTLY FROM PC.....	73
DATA TRANSFER FROM SOUND LEVEL METER TO MEMORY CARD.....	73
TECHNICAL SPECIFICATIONS.....	73
<b>TECHNICAL SPECIFICATIONS.....</b>	<b>74</b>
METROLOGICAL CHARACTERISTICS.....	75
ELECTRICAL CHARACTERISTICS.....	78
STATISTICAL ANALYSIS.....	79
DISPLAY.....	79
STORAGE OF MEASUREMENTS.....	80
PROGRAMS.....	80
OTHER CHARACTERISTICS.....	81
<b>REFERENCE STANDARDS.....</b>	<b>82</b>
EMC STANDARD REGULATIONS.....	82
ITALIAN LAWS.....	82
<b>ORDERING CODES.....</b>	<b>83</b>
ACCESSORIES AND SPARE PARTS.....	85
<b>WHAT SHALL I DO IF.....</b>	<b>86</b>
MEASUREMENT PROCEDURE.....	86
STORAGE OF MEASUREMENTS WITH THE “ADVANCED DATA LOGGER” OPTION.....	87
MEASUREMENT OF NOISE DOSE.....	88
STATISTICAL ANALYSIS.....	89
DATA PRINTING.....	89
<b>TROUBLESHOOTING.....</b>	<b>90</b>
RESTORING FACTORY SETUP.....	90
RESTORING FACTORY CALIBRATION.....	90
MISCELLANEOUS PROBLEMS.....	91
<b>KEYBOARD DESCRIPTION.....</b>	<b>92</b>
<b>ANNEX.....</b>	<b>98</b>
A1. HD2010UC MEASURING PARAMETERS.....	98
A2. MEMORY CAPACITY DURING THE LOGGING FUNCTION.....	101
A3: THE SOUND.....	102
A4: SOUND LEVEL METER.....	104
<i>Frequency Weighting</i> .....	104

<i>Spectral Analysis</i> .....	104
<i>Time constants and exponential weighting</i> .....	105
<i>Impulsive Noises</i> .....	105
<i>Equivalent Sound Pressure Level</i> .....	106
<i>Statistical Analysis</i> .....	107
<i>Noise Dose</i> .....	109
<i>Acoustic Field</i> .....	109
<i>Environmental influence</i> .....	110
<i>Precautions and General rules of use</i> .....	110
<i>Classification of acoustic signals</i> .....	111
A5. MICROPHONE OUTDOOR PROTECTION HD WME - ASSEMBLY, DISASSEMBLY AND MAINTENANCE.....	113
A6: DEFINITIONS.....	120



# GUARANTEE



## TERMS OF GUARANTEE

All DELTA OHM instruments are subject to accurate testing, and are guaranteed for 24 months from the date of purchase. DELTA OHM will repair or replace free of charge the parts that, within the warranty period, shall be deemed non efficient according to its own judgement. Complete replacement is excluded and no damage claims are accepted. The DELTA OHM guarantee only covers instrument repair. The guarantee is void in case of incidental breakage during transport, negligence, misuse, connection to a different voltage than that required for the appliance by the operator. Finally, a product repaired or tampered by unauthorized third parties is excluded from the guarantee. The instrument shall be returned FREE OF SHIPMENT CHARGES to your dealer. The jurisdiction of Padua applies in any dispute.



The electrical and electronic equipment marked with this symbol cannot be disposed of in public landfills. According to the UE Directive 2002/96/EC, the European users of electrical and electronic equipment can return it to the dealer or manufacturer upon purchase of a new one. The illegal disposal of electrical and electronic equipment is punished with an administrative fine.

This guarantee must be sent together with the instrument to our service centre.

**IMPORTANT:** Guarantee is valid only if coupon has been correctly filled in all details.

**Instrument Code:**             **HD2010UC**

Serial number \_\_\_\_\_

## RENEWALS

Date \_\_\_\_\_

Date \_\_\_\_\_

Inspector \_\_\_\_\_

Inspector \_\_\_\_\_

Date \_\_\_\_\_

Date \_\_\_\_\_

Inspector \_\_\_\_\_

Inspector \_\_\_\_\_

Date \_\_\_\_\_

Date \_\_\_\_\_

Inspector \_\_\_\_\_

Inspector \_\_\_\_\_



### CE CONFORMITY

Safety requirements for electrical equipment.	EN61010-1
EMC Generic standards. Immunity for industrial environments.	EN61000-6-2:2005
EMC Generic standards. Emission standards.	EN61000-6-3:2007
Electrostatic discharge immunity test.	EN61000-4-2 level 3
Radiated, radio-frequency, electromagnetic field immunity test.	EN61000-4-3 level 3
Electrical fast transient/burst immunity test.	EN61000-4-4 level 3
Immunity to conducted disturbances, induced by RF fields.	EN61000-4-6
Electromagnetic Interference - Line-conducted disturbances.	EN55022:2007 class B
Electromagnetic Interference - Radiated emissions.	IEC/CISPR 22 class B