



HD 4807T... HD 4907T...  
 HD 48V07T... HD 4901T...  
 HD 4801T... HD 4917T...  
 HD 48V01T... HD 4977T...  
 HD 4817T...  
 HD 48V17T...  
 HD 4877T...  
 HD 48V77T...



**HD 4807T..., HD 48V07T..., HD 48S07T..., HD 4801T...,  
 HD 48V01T..., HD 4817T..., HD 48V17T..., HD 4877T... HD 48V77T...,  
 HD 4907T..., HD 4901T..., HD 4917T..., HD 4977T...**

**PASSIVE OR ACTIVE TEMPERATURE, RELATIVE HUMIDITY, RELATIVE HUMIDITY AND TEMPERATURE, TEMPERATURE AND DEW POINT TRANSMITTERS**

HD48.. and HD49.. series of transmitters measure temperature, relative humidity and the dew point temperature.

Versions with only standard analog output or with only RS485 output with **MODBUS-RTU** protocol are available. The models with analog output provide a signal suitable for transmission to a remote display, recorder or PLC. The models with RS485 output are suitable for connection to a PC or PLC.

The models of the **HD48.. series** are active transmitters and accept both direct and 24Vac alternating power supply; they have standard current (4...20mA) or voltage (0...10V) outputs, or a serial RS485 output, depending on the model. The models of the **HD49.. series** are passive transmitters and thus suitable to be inserted in a 4...20mA current loop. The HD48.. and HD49.. series of transmitters are designed for temperature and humidity control in conditioning and ventilation applications (HVAC/BEMS) in the following sectors: pharmacy, museums, clean rooms, ventilation ducts, industrial and civil sectors, crowded places, canteens, auditoria, gyms, high-density farms, greenhouses, etc.

The HD48.. and HD49.. transmitters measure relative humidity with a well proven temperature compensated capacitive sensor that assures precise and reliable measurements in the course of time. The transmitters of the HD48.. and HD49.. series are available in two probe temperature ranges: **standard -20...+80°C and extended -40...+150°C for the most critical applications.** A stainless steel 20µm filter protects the sensors against dust and particles (other filters are available for different applications).

The transmitters are factory calibrated and no further adjustments are required.

Each series is available in three different versions: with horizontal probe for duct mounting (HD48...TO..., HD49...TO...), with vertical probe for wall mounting (HD48...TV..., HD49...TV...) or with remote probe connected to the transmitter by means of a cable (HD48...TC..., HD49...TC...), cable lengths available are 2, 5 and 10m or for the measure of compressed air in pipelines (HD48...TP480, HD49...TP480). The probes can be supplied in two different lengths (135mm or 335mm).

Various accessories are available for the installation: for example to fix the probe to the duct, it can be used the HD9008.31 flange, a 3/8" universal biconical connection or a PG16 metal cable gland (Ø10...14mm). A 4-digit optional display ("L" model) allows to display the measured parameters in a continuous or sequential mode.

**Technical specifications**

	STANDARD RANGE	EXTENDED RANGE
<b>Relative Humidity</b>		
Sensor	Capacitive	
Measuring range	0...100%RH	
Accuracy @ T=15...35°C	±1.5% RH (0...90%RH), ±2.0% RH (90...100%RH)	
Accuracy @ rest of T range	±(1.5+1.5% of the measure) %RH	
Repeatability	0.4%RH	
Sensor working temperature	-20...+80°C	-40...+150°C
<b>Temperature</b>		
Measuring range	-20...+80°C	-40...+150°C
Sensor	NTC 10kΩ	Pt100 class A
Accuracy	±0.3°C (0...+70°C) ±0.4°C (-20...0°C, +70...+80°C)	±0.3°C
Repeatability	0.05°C	0.05°C
<b>Dew Point</b>		
Sensor	Parameter calculated from relative humidity and temperature	
Measuring range	-20...+80°C DP	
Accuracy	See table 1 below	
Repeatability	0.5°C DP	
<b>Type of output (according to the model)</b>		
Models HD4807T..	Temperature	4...20mA (-20...+80°C), R <sub>i</sub> < 500Ω 22mA outside the measuring range
Models HD4807ET..	Temperature	4...20mA (-40...+150°C), R <sub>i</sub> < 500Ω 22mA outside the measuring range
Models HD48V07T..	Temperature	0...10Vdc (-20...+80°C), R <sub>i</sub> > 10kΩ 11Vdc outside the measuring range
Models HD48V07ET..	Temperature	0...10Vdc (-40...+150°C), R <sub>i</sub> > 10kΩ 11Vdc outside the measuring range
Models HD48S07T.. HD48S07ET..	Temperature	Only RS485 with MODBUS-RTU protocol
Models HD4907T..	Temperature	4...20mA (-20...+80°C), R <sub>i</sub> Max = (Vdc-12)/0.022 22mA outside the measuring range
Models HD4907ET..	Temperature	4...20mA (-40...+150°C), R <sub>i</sub> Max = (Vdc-12)/0.022 22mA outside the measuring range
Models HD4801T.. HD4801ET	Relative Humidity	4...20mA (0...100%RH), R <sub>i</sub> < 500Ω 22mA outside the measuring range
Models HD48V01T.. HD48V01ET..	Relative Humidity	0...10Vdc (0...100%RH), R <sub>i</sub> > 10kΩ 11Vdc outside the measuring range
Models HD48S01T.. HD48S01ET..	Relative Humidity	Only RS485 with MODBUS-RTU protocol
Models HD4901T.. HD4901ET..	Relative Humidity	4...20mA (0...100%RH), R <sub>i</sub> Max = (Vdc-12)/0.022 22mA outside the measuring range
Models HD4817T..	Relative Humidity	4...20mA (0...100%RH), R <sub>i</sub> < 500Ω 22mA outside the measuring range
	Temperature	4...20mA (-20...+80°C), R <sub>i</sub> < 500Ω 22mA outside the measuring range
Models HD4817TV..	Relative Humidity	4...20mA (0...+60°C), R <sub>i</sub> < 500Ω 22mA outside the measuring range
	Temperature	4...20mA (-20...+80°C), R <sub>i</sub> < 500Ω 22mA outside the measuring range
Models HD4817ET..	Relative Humidity	4...20mA (0...100%RH), R <sub>i</sub> < 500Ω 22mA outside the measuring range
	Temperature	4...20mA (-40...+150°C), R <sub>i</sub> < 500Ω 22mA outside the measuring range
Models HD48V17T..	Relative Humidity	0...10Vdc (0...100%RH), R <sub>i</sub> > 10kΩ 11Vdc outside the measuring range
	Temperature	0...10Vdc (-20...+80°C), R <sub>i</sub> > 10kΩ 11Vdc outside the measuring range
Models HD48V17ET..	Relative Humidity	0...10Vdc (0...100%RH), R <sub>i</sub> > 10kΩ 11Vdc outside the measuring range
	Temperature	0...10Vdc (-40...+150°C), R <sub>i</sub> > 10kΩ 11Vdc outside the measuring range
Models HD48S17T.. HD48S17ET	Relative Humidity Temperature	Only RS485 with MODBUS-RTU protocol
Models HD4917T..	Relative Humidity	4...20mA (0...100%RH), R <sub>i</sub> Max = (Vdc-12)/0.022 22mA outside the measuring range
	Temperature	4...20mA (-20...+80°C), R <sub>i</sub> Max = (Vdc-12)/0.022 22mA outside the measuring range
Models HD4917TV..	Relative Humidity	4...20mA (0...100%RH), R <sub>i</sub> Max = (Vdc-12)/0.022 22mA outside the measuring range
	Temperature	4...20mA (0...+60°C), R <sub>i</sub> Max = (Vdc-12)/0.022 22mA outside the measuring range
Models HD4917ET..	Relative Humidity	4...20mA (0...100%RH), R <sub>i</sub> Max = (Vdc-12)/0.022 22mA outside the measuring range
	Temperature	4...20mA (-40...+150°C), R <sub>i</sub> Max = (Vdc-12)/0.022 22mA outside the measuring range
Models HD4877T..	Dew Point	4...20mA (-20...+80°C DP), R <sub>i</sub> < 500Ω 22mA outside the measuring range
	Temperature	4...20mA (-20...+80°C), R <sub>i</sub> < 500Ω 22mA outside the measuring range
Models HD48V77T..	Dew Point	0...10Vdc (-20...+80°C TD), R <sub>i</sub> > 10kΩ 11Vdc outside the measuring range
	Temperature	0...10Vdc (-20...+80°C), R <sub>i</sub> > 10kΩ 11Vdc outside the measuring range
Models HD48S77T..	Dew Point Temperature	Only RS485 with MODBUS-RTU protocol
Models HD4977T..	Dew Point	4...20mA (-20...+80°C DP), R <sub>i</sub> Max = (Vdc-12)/0.022 22mA outside the measuring range
	Temperature	4...20mA (-20...+80°C), R <sub>i</sub> Max = (Vdc-12)/0.022 22mA outside the measuring range
Models HD4877T480	Dew Point	4...20mA (-40...+60°C DP), R <sub>i</sub> < 500Ω 22mA outside the measuring range
	Temperature	4...20mA (-40...+60°C), R <sub>i</sub> < 500Ω 22mA outside the measuring range

Models HD48V77T480	Dew Point	0...10Vdc (-40...+60°C DP), $R_i > 10k\Omega$ 11Vdc outside the measuring range
	Temperature	0...10Vdc (-40...+60°C DP), $R_i > 10k\Omega$ 11Vdc outside the measuring range
Models HD48S77T480	Dew Point	Only RS485 with MODBUS-RTU protocol
	Temperature	
Models HD4977T480	Dew Point	4...20mA (-40...+60°C DP), $R_i \text{ Max} = (Vdc-12)/0.022$ 22mA outside the measuring range
	Temperature	4...20mA (-40...+60°C), $R_i \text{ Max} = (Vdc-12)/0.022$ 22mA outside the measuring range
<b>Power supply and electrical connections</b>		
	<b>HD48..</b>	<b>HD49..</b>
Power supply	16...40Vdc or 24 Vac $\pm 10\%$	12...40Vdc
Electrical connections	Screw type terminal block, max 1,5mm <sup>2</sup> , M16 cable gland for input cable	
<b>General specifications</b>		
Electronics ...TV probes working temperature	0...+60°C	
...TO,...TC Probes working temperature	STANDARD RANGE	EXTENDED RANGE
	-20...+100°C	-40...+150°C
T480 probes working temperature	-40...+60°C	
Storage temperature	-20...+80°C	
electronics protection class	IP66	
Case dimensions	80x84x44	

Table 1 -Accuracy of dew point measurement:

Temperature °C	TD °C								
	-20	-10	0	10	20	30	40	60	80
-20	≤±1								
-10	≤±1	≤±1							
0	≤±1	≤±1	≤±1						
10	≤±3	≤±1	≤±1	≤±1					
20	≤±4	≤±2	≤±1	≤±1	≤±1				
30	≤±3	≤±1,5	≤±1	≤±1	≤±1	≤±1			
40	NOT SPECIFIED			≤±2	≤±1	≤±1	≤±1		
60	NOT SPECIFIED			≤±5	≤±2,5	≤±2	≤±1	≤±1	
80	NOT SPECIFIED			≤±4	≤±2	≤±1	≤±1	≤±1	

For example at 20°C a Dew Point value of 0°C DP is measured with an accuracy better than 1°C DP.

#### Installation notes

To fix the probe inside a ventilation duct, a pipe, etc., use for example the HD9008.31 flange, a PG16 metal cable gland (Ø10...14mm) or a 3/8" universal biconical connection.

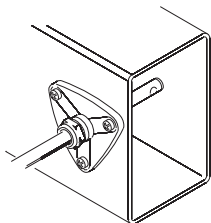

**HD9008.31 Flange**

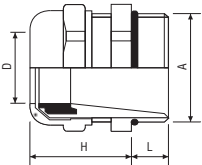

**PG16 metal cable gland**

D = 10...14mm  
L = 6.5mm  
H = 23mm  
A = PG16

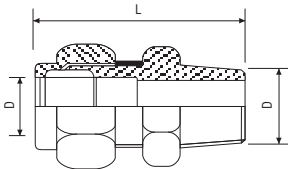

**Universal biconical connector**

L = 35mm  
D = 14mm  
A = 3/8"

#### Electrical connections

##### HD48.. series with analog output

Power the instrument as shown in the below connection schemes, the power supply terminals are marked as +Vcc and GND.

Depending on the model, the output signal is available between:

- Ta and AGND terminals for the transmitters of the HD4807T..and HD48V07T... series.
- RH% and AGND terminals for the transmitters of the HD4801T.. and HD48V01T.. series.
- RH% and AGND, Ta and AGND terminals for the transmitters of the HD4817T.. and HD48V17T.. series.
- DP and AGND, Ta and AGND terminals for the transmitters of the HD4877T.. and HD48V77T.. series.

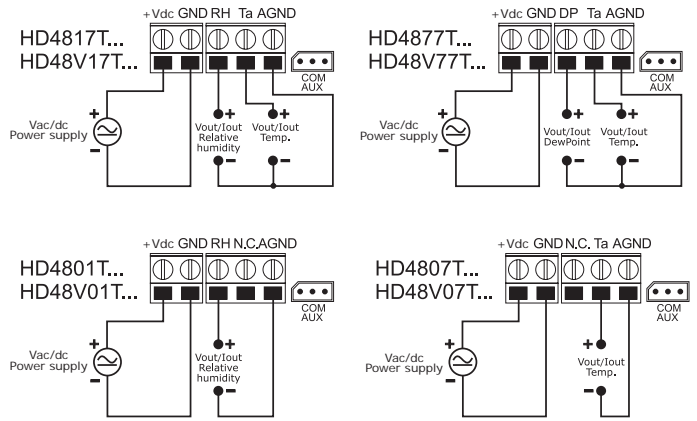

#### HD48...series with RS485 output

Connect the instrument as shown in the below connection schemes, the power supply terminals are marked as +Vcc and GND.

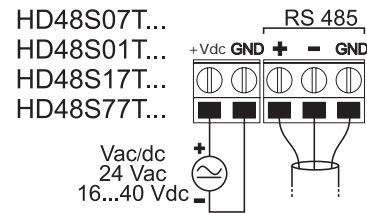

Thanks to RS485 output, several instruments can be connected to form a network. The instruments are connected in a sequence through a shielded cable with twisted pair for signals and a third wire for the mass.

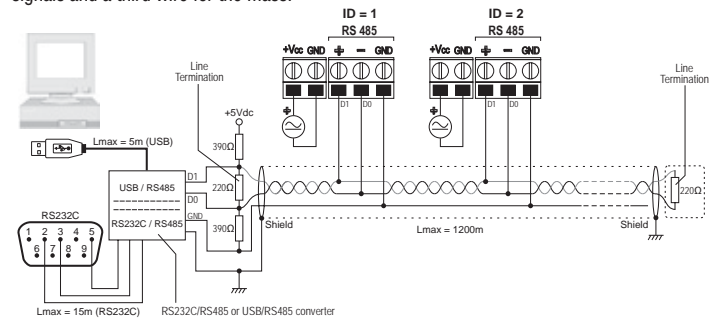

Line termination must be set at the two network ends. To polarize the line during non-transmission periods, resistors are connected between signal and power supply lines.

The maximum number of devices that can be connected to the (Bus) line RS485 depends on the load characteristics of the devices to be connected.

The standard RS485 requires that the total load does not exceed 32 Unit Loads. The load of a HD48S.. transmitter is equal to 1/4 of the unit load.

If the total load is more than 32 unit loads, divide the net in segments and insert a signal repeater between one segment and the next one. At the beginning and at the end of each segment a line termination must be connected.

The instrument has a built in line termination that can be connected or removed through a short jumper placed next to the terminal block. If the instrument is the last or the first device of a network group, connect the termination placing the short jumper between the "RT" and "240 ohm" indications. If the instrument is not at the end of a network group, remove the termination placing the short jumper between the "RT" and "OPEN" indications.

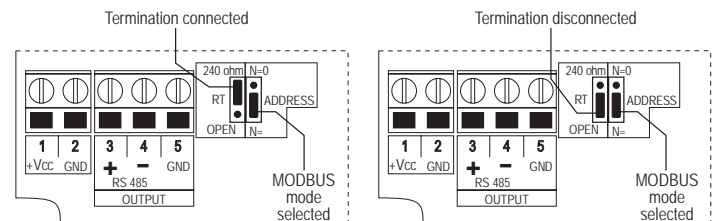

The cable shield must be connected to both line ends. The cable should have the following features:

- Characteristic impedance: 120 ohm
- Capacity: less than 50pF/m
- Resistance: less than 100 ohm/km
- gauge: 0,22 mm<sup>2</sup> (AWG24) at least.

The cable maximum length depends on baud rate and cable characteristics. Typically, the maximum length is 1200m. The data line must be kept separated from any power lines in order to prevent interferences on the transmitted signal. For connection to a PC, a RS232/RS485 or a USB/RS485 converter must be used. To operate with the MODBUS-RTU protocol be

sure that the ADDRESS short jumper is between "ADDRESS" and "N=" indications. Each transmitter of the network is univocally identified by an address. The address must be between 1 and 247. **There must not be any other transmitters connected with the same address.** The address must be configured before connecting the instrument to the network. To set the instrument address use the **HD48STCAL** kit. The kit includes the **RS48** cable with built in USB/RS485 adapter and a CD-ROM for Windows® operating systems. To configure the instrument it is necessary to move the ADDRESS short jumper between the "ADDRESS" and "N=0" indications to select the setup mode. After the configuration, move the short jumper back between the "ADDRESS" and "N=" indications. In MODBUS mode it is possible to read the measured values by the instrument through the 04h functioning code (Read Input Registers). Table 2 represents the available quantities with its relative register address.

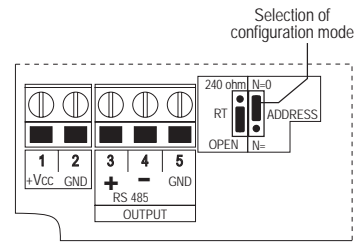
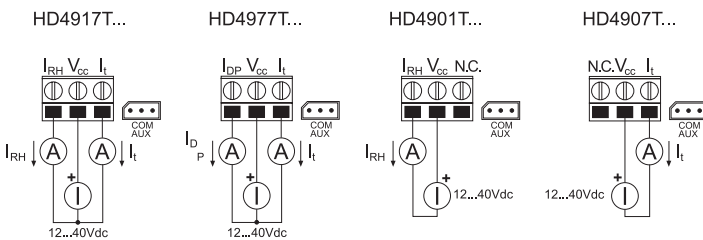

**Table 2 – Modbus Registers**

Address	Quantities	Format
0	Temperature in °C (x10)	Complete 16 bit
1	Temperature in ° (x10)	Complete 16 bit
2	Relative Humidity in % (x10)	Complete 16 bit
3	Dew Point in °C (x10)	Complete 16 bit
4	Dew Point in °F (x10)	Complete 16 bit
5	State register Bit 0 = 1 → temperature measure in error Bit 1 = 1 → relative humidity measure in error Bit 2 = 1 → dew point temperature calculation in error Bit 3 = 1 → error in data configuration	Complete 16 bit

**HD49.. series**

Follow the connection schemes shown below, the maximum load resistance that can be connected to each 4...20mA output depends on the power supply Vcc applied, according to the relation:  
 $R_{iMax} = (Vdc - 12) / 0.022$ , e.g. if Vdc=24Vdc the max load is  $R_{iMax} = 545$  ohm.



**Relative humidity probe calibration**

The HD48.. and HD49.. transmitters are supplied factory calibrated and ready to use. If necessary, it is possible to calibrate the relative humidity sensor using the saturated salt solutions **HD75** (75% RH saturated salt solution) and **HD33** (33% RH saturated salt solution) and connecting the instrument to the PC using the HD48TCAL kit. The **HD48TCAL** kit includes the CP27 with incorporated convertor USB/RS232 for the transmitters connection to the PC and a CD-ROM for Windows operating systems, that guides the user in the relative humidity probe calibration procedure. For RS485 output models use the **HD48STCAL**. The kit includes the **RS48** with incorporated convertor USB/RS232 for the transmitters connection to the PC and a CD-ROM for Windows operating systems, that guides the user in the relative humidity probe calibration procedure. To calibrate the instrument it is necessary to move the ADDRESS short jumper between the "ADDRESS" and "N=0" indications to select the setup mode. After the calibration, move the short jumper back between the "ADDRESS" and "N="

**Case dimensions**

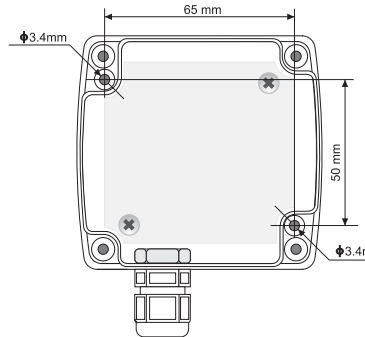
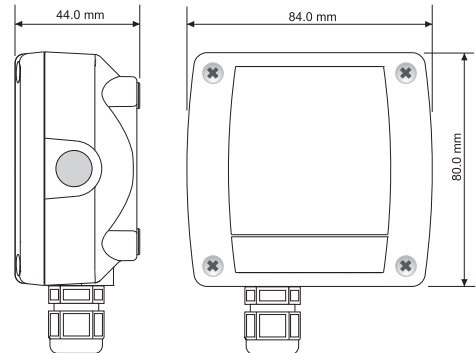

**Probe dimensions: TO series**

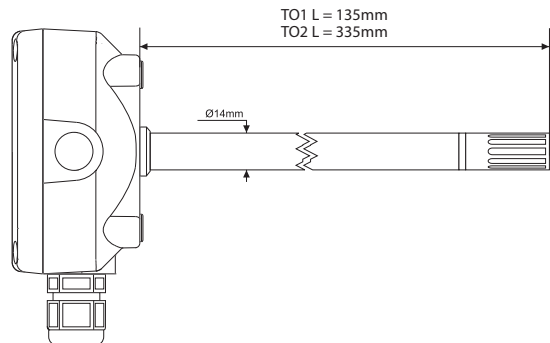

**TC series**

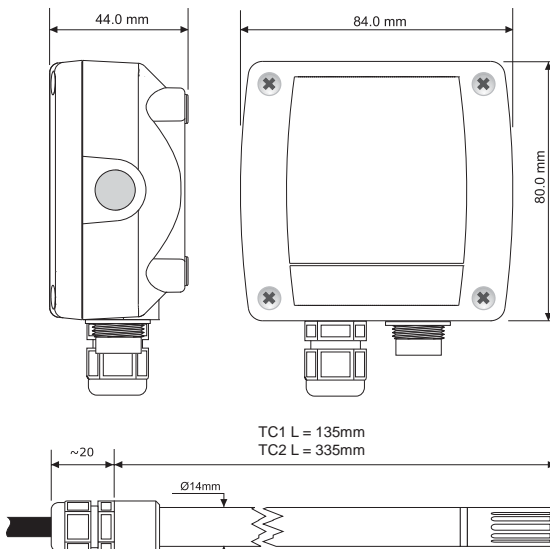

## Ordering codes

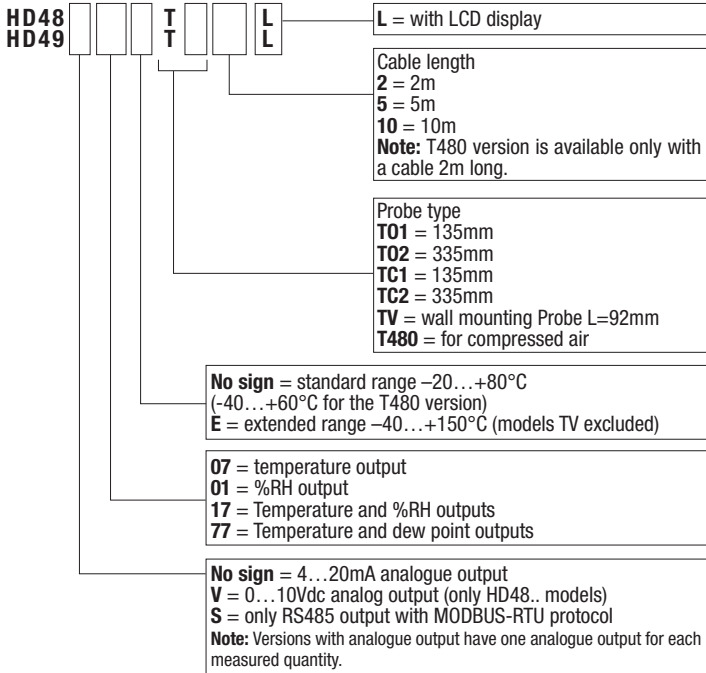

## TV series

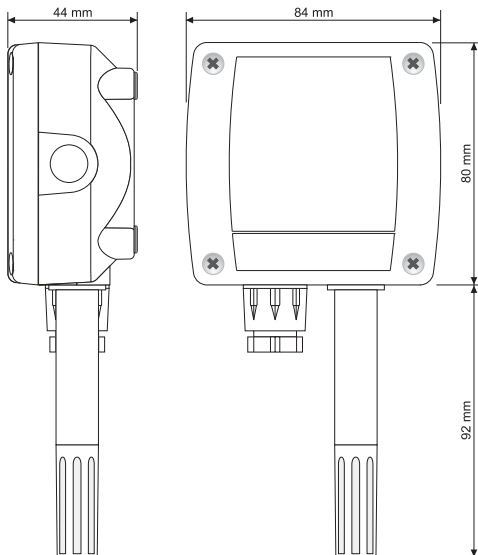

## Ordering code examples

**HD4801TV:** Wall mounting digital active relative humidity transmitter.

Relative humidity range 0...100%RH.

Analog output: 4...20mA (0...100%RH).

Probe working range -20...+80°C. Power supply 16...40Vdc or 24Vac.

**HD4917T01:** Digital passive (current loop) temperature and relative humidity transmitter for duct mounting. AISI304 steel probe, diameter 14mm and stem length 135mm, joined to the electronics enclosure.

Relative humidity range 0...100%RH, temperature range -20...+80°C.

Analog outputs: 4...20mA (0...100%RH) for RH and 4...20mA (-20...+80°C) for temperature. Probe working range -20...+80°C. Power supply 12...40Vdc.

**HD4817TC25L:** Digital active temperature and relative humidity transmitter with LCD display. AISI304 steel probe, diameter 14mm and stem length 335mm, connected to the electronics enclosure through a 5m cable.

Relative humidity range 0...100%RH, temperature range -20...+80°C.

Analog outputs: 4...20mA (0...100%RH) for RH and 4...20mA (-20...+80°C) for temperature. Probe working range -20...+80°C. Power supply 16...40Vdc or 24Vac.

**HD48V17ETC25:** Digital active temperature and relative humidity transmitter, extended range. AISI304 steel probe, diameter 14mm and stem length 335mm, connected to the electronics enclosure through a 5m cable.

Relative humidity range 0...100%RH, temperature range -40...+150°C.

Analog outputs: 0...10V (0...100%RH) for RH and 0...10V (-40...+150°C) for temperature. Probe working range -40...+150°C. Power supply 16...40Vdc or 24Vac.

**HD48S17TC25L:** Digital active temperature and relative humidity transmitter with LCD display. AISI304 steel probe, diameter 14mm and stem length 335mm, connected to the electronics enclosure through a 5m cable.

Relative humidity range 0...100%RH, temperature range -20...+80°C.

Only RS485 output with MODBUS-RTU protocol. Probe temperature working range -20...+80°C. Power supply 16...40Vdc or 24Vac.

**HD4877T02:** Digital active temperature and dew point transmitter for duct mounting. AISI304 steel probe, diameter 14mm and stem length 135mm, joined to the electronics enclosure.

Dew point range -20...+80°C DP, temperature range -20...+80°C.

Analog outputs: 4...20mA (-20...80°C DP) for DP and 4...20mA (-20...+80°C) for temperature. Probe working range -20...+80°C. Power supply 16...40Vdc or 24Vac.

**HD4977T02:** Digital passive (current loop) temperature and dew point transmitter for duct mounting. AISI304 steel probe, diameter 14mm and stem length 335mm, joined to the electronics enclosure.

Dew point range -20...+80°C DP, temperature range -20...+80°C.

Analog outputs: 4...20mA (-20...+80°C DP) for DP and 4...20mA (-20...+80°C) for temperature. Probe working range -20...+80°C. Power supply 12...40Vdc.

## Accessories

**HD48TCAL:** The kit includes the CP27 connection cable with built-in USB/RS232 converter and CD-ROM for Windows operating systems that guides the user in the relative humidity probe calibration procedure. The cable is complete of USB connector on the PC side and a COM AUX connector on the instrument side. The kit is suitable only for analog output models.

**HD48STCAL:** The kit includes the RS48 cable with built-in USB/RS485 converter and CD-ROM for Windows operating systems that guides the user in the relative humidity probe calibration procedure. The cable is complete of USB connector on the side of the PC and of 3 separate wires on the instrument part. The kit is suitable only for RS485 output models.

**RS48:** Cable for RS485 serial connection with built-in USB/RS485 converter.

**CP27:** Connection/converter cable from COM AUX serial port to USB.

**HD75:** 75% RH saturated solution for the verification of the relative humidity sensor, complete of screw adaptors for probes with Ø 14mm and Ø 26mm.

**HD33:** 33% RH saturated solution for the verification of the relative humidity sensor, complete of screw adaptors with Ø 14mm and Ø 26mm.

**HD9008.31:** Wall flange with cable gland to fix Ø 14mm probes.

**PG16:** AISI304 steel cable gland for Ø 14mm probes.

**P6:** 10µ sintered stainless steel protection for Ø 14mm probes.

**P7:** 20µ PTFE protection for Ø 14mm probes.

**P8:** Stainless steel grid 20µ and Pocan for Ø 14mm probes.



**SETTING THE RS485 COMMUNICATION PARAMETERS OF THE TRANSMITTER WITH A STANDARD COMMUNICATION PROGRAM**

Before connecting the transmitter to the RS485 network, an address must be assigned and the communication parameters be set, if different from the factory preset.

The parameters setting is performed as follows:

- If you have the **RS48** cable, install the drivers in the PC.
- Connect the transmitter to a PC USB port using the cable **RS48** (or alternatively through another USB/RS485 converter available, ensuring that their drivers are installed in the PC).
- Move the ADDRESS jumper between the sign "ADDRESS" and "N = 0" to select the configuration mode (see technical sheet to locate the jumper).
- Start a communication program such as Hyperterminal, and set the serial communication parameters as follows (the instrument is connected to a COM port type):

Baud rate: 115200  
 Parity: None  
 Data Bits: 8  
 Stop Bits: 2

- Send the serial commands given in the following table to set the RS485 MODBUS parameters:

Command	Response	Description
MA nnn	&	Set RS485 address Ranging from 1 to 247 Preset on 1
MB n	&	Set RS485 Baud Rate n=0 ⇒ 9600 n=1 ⇒ 19200 Preset on 1 ⇒ 19200
MP n	&	Set RS485 transmission mode n=0 ⇒ 8-N-1 (8 data bits, no parity, 1 stop bit) n=1 ⇒ 8-N-2 (8 data bits, no parity, 2 stop bits) n=2 ⇒ 8-E-1 (8 data bits, even parity, 1 stop bit) n=3 ⇒ 8-E-2 (8 data bits, even parity, 2 stop bits) n=4 ⇒ 8-O-1 (8 data bits, odd parity, 1 stop bit) n=5 ⇒ 8-O-2 (8 data bits, odd parity, 2 stop bits) Preset on 2 ⇒ 8-E-1
MW n	&	Set receiving mode after RS485 transmission n=0 ⇒ Violates the protocol and gets in listen mode immediately after the transmission n=1 ⇒ Respects the protocol and waits 3.5 characters after the transmission Preset on 1 ⇒ Respects the protocol

- You can check the parameters setting and read the information of the instrument by sending the following serial commands:

Command	Response	Description
G0		Transmitter Model
G2		Serial number of the transmitter
G3		Firmware Version
G4		Firmware Date
L1	<i>Address</i>	Read RS485 address
L2	<i>Baud Rate</i> (0,1)	Read RS485 Baud Rate 0 ⇒ 9600 1 ⇒ 19200
L3	<i>Tx Mode</i> (0,1,2,3,4,5)	Read RS485 transmission mode 0 ⇒ 8-N-1 1 ⇒ 8-N-2 2 ⇒ 8-E-1 3 ⇒ 8-E-2 4 ⇒ 8-O-1 5 ⇒ 8-O-2
L4	<i>Rx Mode</i> (0,1)	Read receiving mode after RS485 transmission 0 ⇒ Violates the protocol and gets in listen mode immediately after Tx 1 ⇒ Respects the protocol and waits 3.5 characters after Tx
P0	&	Ping

- When finished, reposition the ADDRESS jumper between the indications "ADDRESS" and "N =" to restore the MODBUS mode.

### READING OF THE MEASURES WITH THE MODBUS-RTU PROTOCOL WHEN THE INSTRUMENT IS IN OPERATING CONDITIONS (INSTALLED IN A NETWORK)

In MODBUS mode, you can read the values measured by the instrument through the function code 04h (Read Input Registers). The following table lists the quantities available with the appropriate register address:

Address	Quantity	Format
0	Temperature in °C (x10)	16-bit Integer
1	Temperature in °F (x10)	16 bit Integer
2	Relative Humidity in % (x10)	16-bit Integer
3	Dew Point in °C (x10)	16 bit Integer
4	Dew Point in °F (x10)	16-bit Integer
5	Status register bit 0 = 1 ⇒ temperature measurement error bit 1 = 1 ⇒ humidity measurement error bit 2 = 1 ⇒ dew point calculation error bit 3 = 1 ⇒ configuration data error	16-bit Integer