

The **atmospheric luminance (L_{atm})** is evaluated with the HD2021T7 probe by measuring the luminance for subtended angles less than 1° (2° total opening) as reported in Tables B and C of the test report.

The contribution of the **luminance of the windshield (L_{par})** is measured directly by inserting the HD2021T7 probe in a protective case. The dialog interface that separates the probe from the external environment simulates the behaviour of the windshield, so the value read by the probe in the container already includes this contribution.

INSTRUMENT TECHNICAL SPECIFICATIONS

Dimensions

(Length x Width x Height) 147mm x 58 mm x 65mm

Figure 1 Dimensions of the HD2021T7 probe

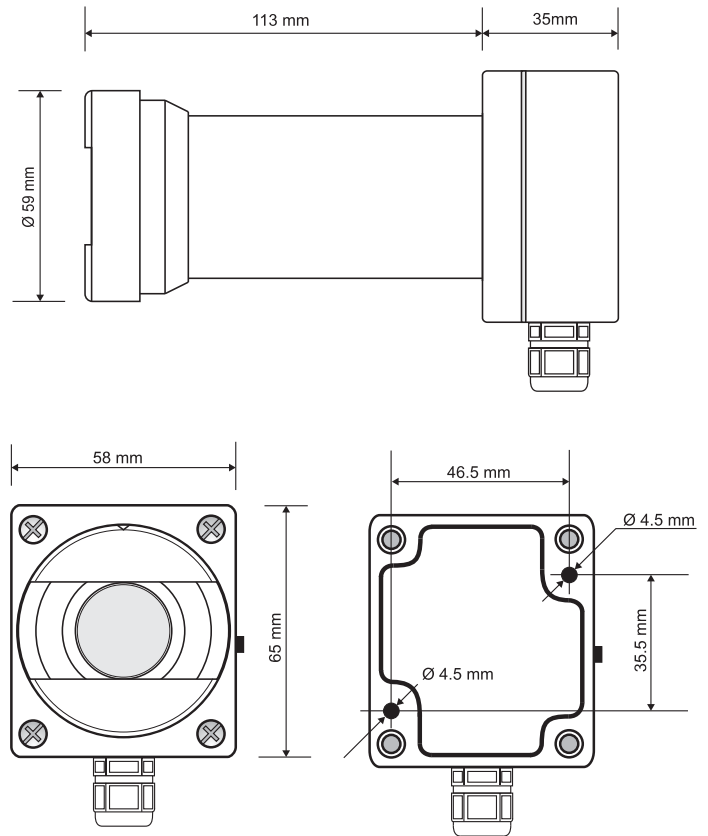

**HD 2021T7, HD 2021T6
DEBILITATING LUMINANCE PROBE,
LUMINANCE PROBE**

HD2021T7

The HD2021T7 probe allows converting the photometric quantity “debilitating luminance” into a current (4...20 mA) or a voltage (0...10 V) signal according to the version chosen. If the acquisition station is far from the probe (>50m), it is necessary to use the current output version.

The HD2021T7 transmitter has IP67 protection. In order to grant high accuracy, it is important to keep the surface of the outer lens clean. It is possible to wash them by using only water and standard papers for lens. The transmitter full scale can be chosen (when ordering) between two different values: 2000cd/m² or 20000cd/m². For orders of at least 5 pieces, it is possible to calibrate the scale to a value chosen by the customer.

The probe is used for the control of street lighting, in particular, the measurement of debilitating luminance is essential to determine the *threshold luminance* at the entrance of the tunnels (UNI 11095:2011).

The measurement of debilitating luminance (L_v) consists of three components:

$$L_v = L_{seq} + L_{alm} + L_{par}$$

where,

L_{seq} is the equivalent veiling luminance;

L_{alm} is the atmospheric luminance;

L_{par} is the luminance of the windshield.

The **equivalent veiling luminance (L_{seq})** is measured according to standard UNI11095: 2005 with the probe HD2021T7 as reported in the test report I.N.Ri.M. 08-1199-01. This quantity is measured and defined starting from the subtended angles greater than 1° .

SPECTRAL RESPONSE

The probe uses a silicon photodiode and a set of filters to correct the spectral response curve to make it equal to that of the human eye (photopic response). Figure 2 shows the trend of the relative spectral response according to the wavelength.

$f'_1 < 9\%$ according to the standard photopic curve $V(\lambda)$.

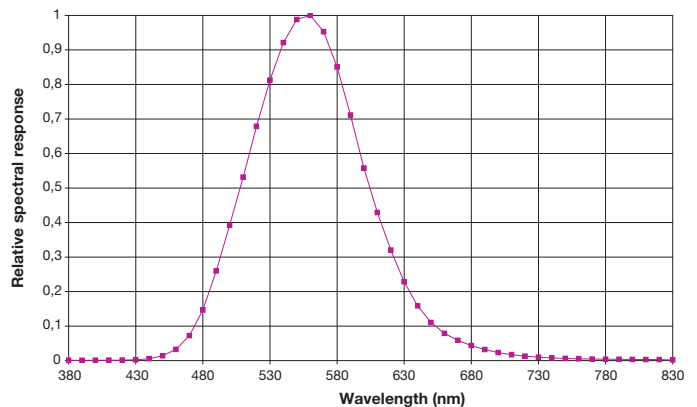

Figure 2. HD2021T7 Relative spectral response

ANGULAR RESPONSE:

The equivalent veiling luminance (L_v) is estimated starting from the following formula:

$$L_v = 10 \sum_{\beta=1^\circ}^{\beta=90^\circ} \frac{L(\beta) \cdot \cos(\beta)}{\beta \cdot (\beta + 1.5)} \cdot \Omega \quad \mathbf{A}$$

where:

- $L(\beta)$ is the luminance of a source of disturbance measured at an angle β ,
- β is the angle between the pointing direction of the object to be watched and the source of interference,
- Ω is the solid angle

Figure 3 shows the sensitivity as a function of the angle of the probe. In the standard CIE88:2004 the equivalent veiling luminance is calculated by considering the contributions up to angles of 28.4°. By using DeltaOhm probe HD 2021T7 it is possible to evaluate contributions to greater angles (up to 40°).

Figure 3. HD2021T7 Relative angular response

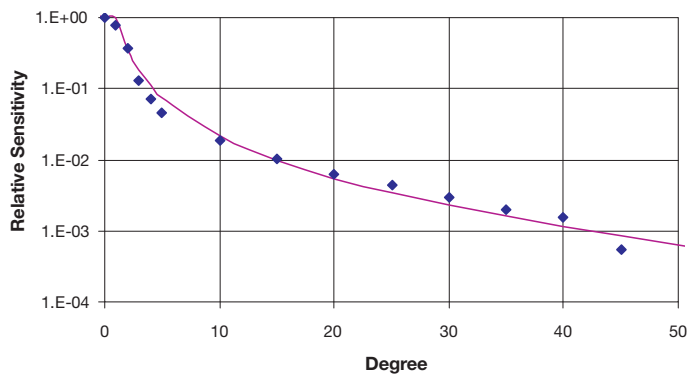

For angles less than 1° as shown in fig.3 the probe measures the luminance necessary for the proper calculation of the contributions of the atmospheric luminance and the luminance of windshield.

WORKING TEMPERATURE

The probe can work in a temperature range from -20° to +60° C. If the probe is placed in watertight containers, take care that there is no fogging or condensation on the window towards which the probe is overlooking. In this case the reading of the equivalent veiling luminance would be altered by systematic errors.

CALIBRATION

The calibration of the probe HD2021T7 is carried out by measuring the luminance on the output port of an integrating sphere with a known luminance. If requested, the uncertainty of the calibration of the probe with fixed full scale is 10% (confidence level of 95%).

TRANSMITTER INSTALLATION

The installation of the probe for the evaluation of the *threshold luminance* at the entrance of tunnels should be performed in compliance with the standard UNI 11095.

In order to connect the transmitter, it is necessary to lift the lid (by unscrewing the four locking screws). For the 4...20mA version, please refer to Figure 5, while the version 0...10 V is referred to Figure 4.

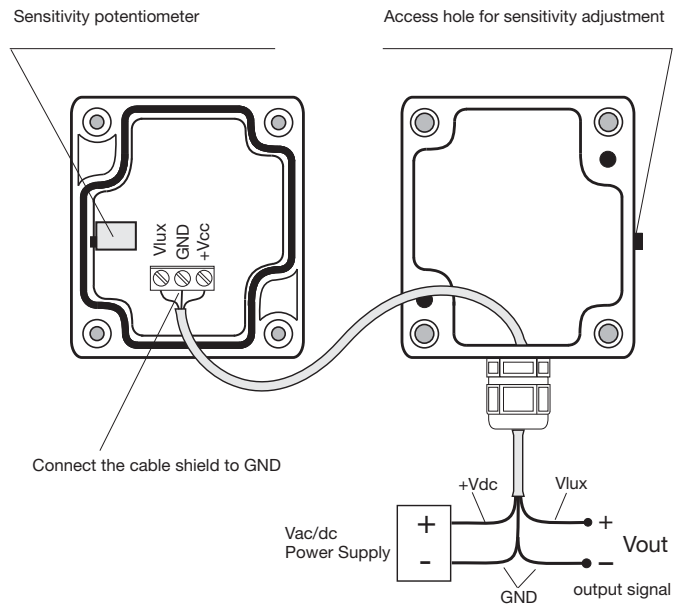

Figure 4. Connection diagram for HD2021T... with voltage output

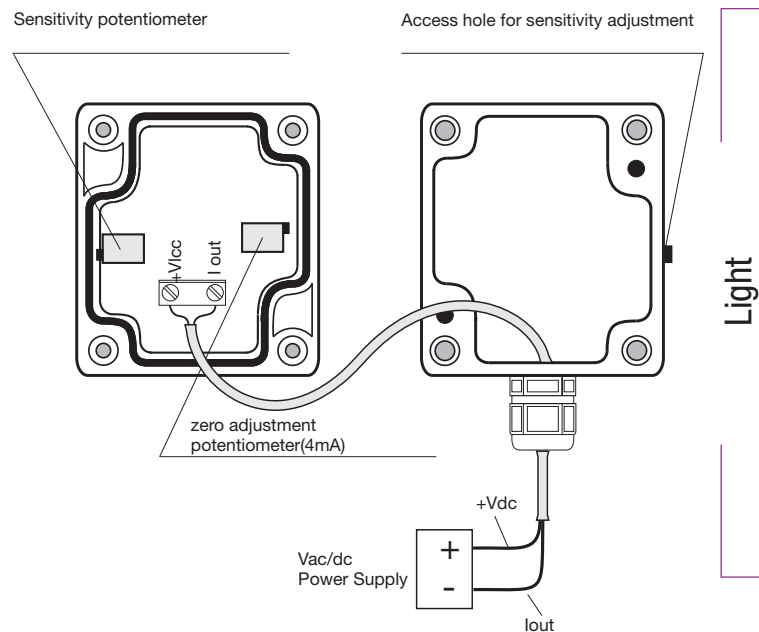

Figure 5. Connection diagram for HD2021T... with current output

ORDERING CODES:

	Output	Measurement range	Power supply	Spectral response
HD2021T7A.V	0...10 V	0...2000 cd/m ²	16...40 Vac/dc	V(λ)
HD2021T7B.V		0...20 kcd/m ²		
HD2021T7X.V		Upon request *		
HD2021T7A.A	4...20 mA	0...2000 cd/m ²		
HD2021T7B.A		0...20 kcd/m ²		
HD2021T7X.A		Upon request *		

*minimum order 5 pcs

HD2021T6

The probe HD 2021T6 allows converting a photometric quantity Luminance (cd/m^2) into a current (4...20 mA) or voltage (0...10 V) signal according to the version chosen. If the acquisition station is far from the probe (>50m), the current version is required.

The protection degree of the transmitter HD2021T6 is IP67. In order to ensure correct measurements, the outer surface of the lens must be kept clean. If necessary, clean the lens with water and lens cleaning paper.

At the order time, it is possible to choose the transmitter sensitivity among three previously set values: $2 \text{ kcd}/\text{m}^2$, $20 \text{ kcd}/\text{m}^2$ or $200 \text{ kcd}/\text{m}^2$. For orders of quantities over 5 pieces, the full scale can be customized.

The probe is used for road lighting control. In particular, the measurement of luminance at a 20° angle (L_{20}) is necessary to estimate *threshold luminance* at tunnel entrances (CIE standard 88:2004. This standard foresees the measurement of debilitating luminance in future).

Moreover, the probe can be used for calculating vertical illuminance (E_v) as prescribed in the above-mentioned standard.

Finally, the probe can be used for any application where the measurement of luminance is required, for example projector screens, diaphanoscopes etc.

Instrument technical specifications

Dimensions

(Length x Width x Height) 145mm x 58 mm x 65mm

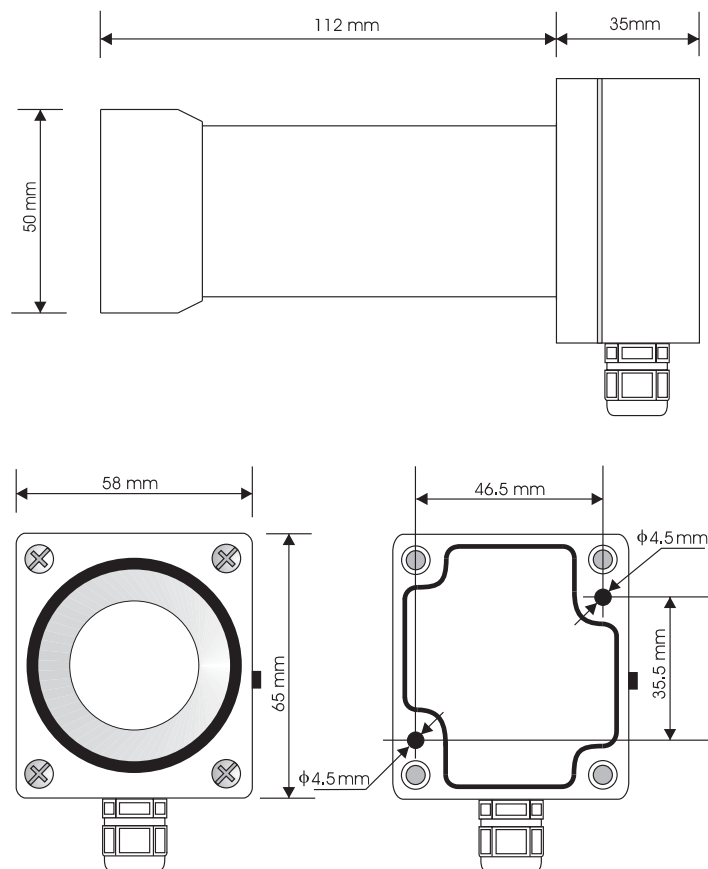

Figure 1. HD2021T6 probe dimensions

Spectral Response

The probe is equipped with a silicon photodiode and a series of filters to correct the spectral response curve and make it equal to that of the human eye (photopic response). Figure 2 shows the trend of the relative spectral response depending on the wavelength.

$f'_1 < 9\%$ according to the standard photopic curve $V(\lambda)$.

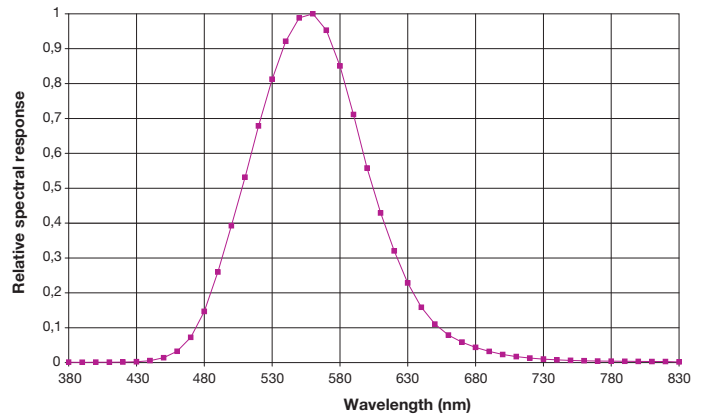

Figure 2. HD2021T6 probe relative spectral response

FIELD OF VIEW

The total field of view of HD2021T6 probe is 20° .

WORKING TEMPERATURE

The probe can work in a temperature range from -20° to $+60^\circ$ C. If the probe is placed in watertight containers, take care that there is no fogging or condensation on the window towards which the probe is overlooking. In this case the reading of the equivalent veiling luminance would be altered by systematic errors.

CALIBRATION

The calibration of the probe HD2021T6 is carried out by measuring the luminance on the output port of an integrating sphere with a known luminance. If requested, the uncertainty of the calibration of the probe with fixed full scale is 5% (confidence level of 95%).

TRANSMITTER INSTALLATION

The installation of the probe for the evaluation of the *threshold luminance* at the entrance to the galleries has to be performed according to standard CIE 88:2004.

In order to connect the transmitter, it is necessary to lift the lid (by unscrewing the four locking screws). For the 4...20mA version refer to Figure 5, while for the version 0...10 V refer to Figure 4 of HD2021T7.

ORDERING CODES:

Model	Output	Measurement range	Power supply	Spectral Response
HD2021T6A.V	0...10 V	0...2000 cd/m^2	16...40 Vac/dc	$V(\lambda)$
HD2021T6B.V		0...20 kcd/m^2		
HD2021T6C.V		0...200 kcd/m^2		
HD2021T6X.V		Upon request *		
HD2021T6A.A	4...20 mA	0...2000 cd/m^2		
HD2021T6B.A		0...20 kcd/m^2		
HD2021T6C.A		0...200 kcd/m^2		
HD2021T6X.A		Upon request *		

*minimum order 5 pieces