

Operating manual

Tipping bucket rain gauge **HD2015**



Companies / Brands of GHM

Members of GHM GROUP:

GREISINGER

HONSBERG

Martens

IMTRON

Delta OHM

VAL.CO

www.deltaohm.com

Keep for future reference.

TABLE OF CONTENTS

1	INTRODUCTION	3
2	TECHNICAL CHARACTERISTICS	4
3	INSTALLATION	6
3.1	ELECTRICAL CONNECTIONS	6
3.2	TIPPING BUCKET.....	7
3.3	INSTALLATION MODES	8
4	MAINTENANCE	11
5	INSTRUMENT STORAGE	13
6	SAFETY INSTRUCTIONS	13
7	ORDERING CODES	14

1 INTRODUCTION

HD2015 is a reliable and sturdy bucket rain gauge, entirely constructed of corrosion resistant materials in order to guarantee its durability. To ensure accurate measurements even with low temperature climatic conditions or during and after precipitations of snow, a version with heating system, automatically activated around +4 °C has been developed to prevent snow deposits and ice formations.

The rain gauge is formed by a metal base on which a tipping bucket is set. The rain collector cone, fixed to the aluminium cylinder, channels the water inside the tipping bucket: once the predefined level is reached, the calibrated bucket rotates under the action of its own weight, discharging the water. During the rotation phase, the normally closed reed contact opens for a fraction of a second, sending an impulse to the counter.

The quantity of rainfall measured is based on the count of the number of times the bucket is emptied: the reed contacts, normally closed, open at the moment of the rotation between one bucket's section and the other. The number of impulses can be detected and recorded by a data logger such as the **HD2013-DB** or by a pulse counter.

A removable filter for periodic cleaning and maintenance is inserted in the water collector cone so as to prevent leaves or other elements blocking the end of the hole.

For a better water flow, the collecting cone is treated with a non-stick coating.

The version with heating option **HD2015R** works with 12 Vdc or 24 Vdc direct voltage (**to be specified at the time of order**) and absorbs about 50 W. The heating system is activated around +4 °C.

When submitting your order, it is possible to request a bird dissuader, made of eight 3 mm diameter spikes, 60 mm in height, to be installed on the rain gauge.

2 TECHNICAL CHARACTERISTICS

	HD2015R	HD2015
Power supply	12 Vdc or 24 Vdc \pm 10% / 50 W (to be specified when ordering)	---
Type of output contact	NC contact (opens during tipping)	
Resolution	0.1 – 0.2 or 0.5 mm/tip to be specified at the time of placing the order	
Accuracy	<p>+2.5...-2.5% in the interval 0...100 mm/h (version with 0.2 mm @ 50 mm/h nominal resolution)</p> <p>+1.5...-1.5% in the interval 0...100 mm/h (version with 0.5 mm @ 50 mm/h nominal resolution)</p> <p>The error refers to the calculation of the amount of rain using the resolution stated in the rain gauge label. If the amount of rain is calculated using the correction curve as a function of the rainfall rate (fig. 1 and 2), the error is typically less than \pm 2% in the interval 0...200 mm/h.</p> <p>If the HD2013-DB data logger is used, the measurement can be automatically corrected according to the graphs in fig. 1 and 2.</p>	
Maximum rainfall rate	600 mm/h (version with 0.2 mm nominal resolution) 1000 mm/h (version with 0.5 mm nominal resolution)	
Operating temperature range	-20 °C ...+70 °C	+4 °C ...+70 °C
Heating intervention temperature	+4 °C	---
Protection degree	IP 64	
Collector area	200 cm ²	
Minimum section of the wires of the connecting cable	0.5 mm ² for the version without heating system (HD2015) 2.5 mm ² for the version with heating system (HD2015R)	

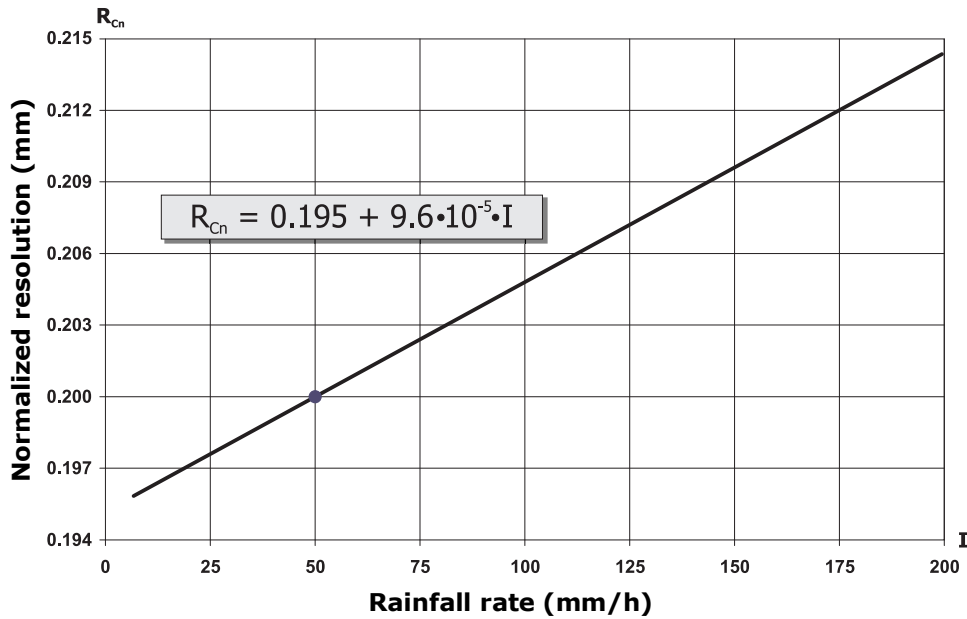

Fig. 1 – Normalized resolution (0.2 mm @ 50 mm/h) as a function of the rainfall rate

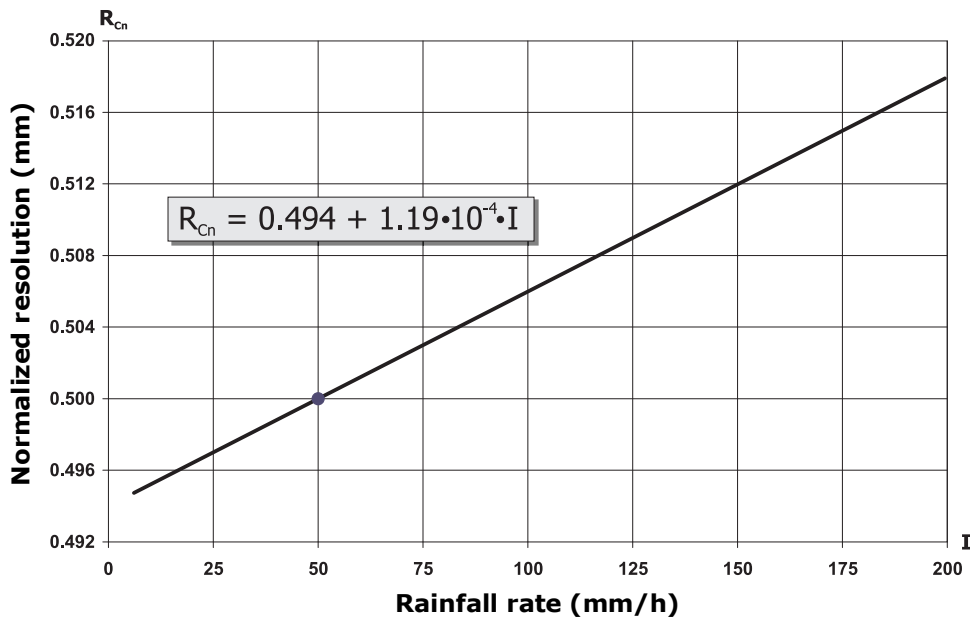

Fig. 2 – Normalized resolution (0.5 mm @ 50 mm/h) as a function of the rainfall rate

To correct the measurement depending on the rainfall rate, it is necessary to log, in addition to the number of pulses, also the instants at which the pulses occur.

Example of measurement correction:

Let's assume that a rain gauge with nominal resolution $R_N = 0.209$ mm @ 50 mm/h has generated 25 pulses at the frequency of 1 pulse every 50 seconds.

The rainfall rate can be estimated considering the nominal resolution R_N and the interval between two successive pulses: $I = 0.209 \times 3600 / 50 \approx 15$ mm/h.

From the linear equation in fig. 1 we obtain the normalized corrected resolution: $R_{Cn} = 0.196$ mm.

The corrected resolution of the rain gauge is: $R_C = R_{Cn} \times R_N / 0.2 = 0.205$ mm.

The amount of rain detected is $25 \times 0.205 = 5.125$ mm.

3 INSTALLATION

The rain gauge is supplied already calibrated at 0.1 - 0.2 or 0.5 mm of rain per tip of the bucket: the calibration value is shown on the instrument label.

The instrument must be installed in an open area, away from buildings, trees, etc., ensuring that the space above is free from objects which may obstruct the rain measurements and placed in an easily accessible position for periodical cleaning of the filter.

Avoid installations in areas exposed to wind gusts, turbulences (for example on the top of a hill) as they may distort the measurements.

The rain gauge can be installed on the ground or 500 mm off the ground. Other sizes of the support for installation off the ground are available upon request.

For the installation on the floor, three adjustable support feet are supplied, so that the instrument can be levelled correctly, and also proper holes for a possible fixing on a floor.

For installations off the ground, a flange to be fixed to the base of the instrument, where the support clamp must be inserted, is supplied; the clamp ends either with a flange so that it can be fixed to the floor, or with a tip to be driven into the ground. For the various fastening systems please refer to the figures 5, 6, 7 and 8.

In order to make the tipping device properly working and the measurements correct, it is important that the instrument is placed perfectly levelled. The base of the rain gauge is fitted with a bubble level.

For the installation, unscrew the three screws from the base of the cylinder that supports the water collector cone (see fig. 2). A heating resistor is placed around the cone in the **HD2015R** version. The heater is automatically disconnected when the cone is lifted up.

3.1 ELECTRICAL CONNECTIONS

For the version without heating system, use a 2-wire cable with 0.5 mm² minimum wires section; for the version with heating system, use a 4-wire cable with 2.5 mm² minimum wires section. Use a shielded cable over long distances. Slide the cable through the cable gland and fasten it with the cable fastener located near the entry hole, at the base of the rain gauge.

Unscrew the terminal block protection cover and perform the connections as shown in figure 2. **The rain gauge output, indicated in point 1 of the drawing below, must be connected to the input of the HD2013-DB rain gauge data logger** (please see the details in the manual of the data logger) **or to a pulse counter or to a data logger.**

The heated version requires power for the resistors (12 Vdc or 24 Vdc depending on the version supplied): perform the connection as indicated at point 2 of fig. 3.

If the connections are correctly set, the LED placed near the terminals will be lit up.

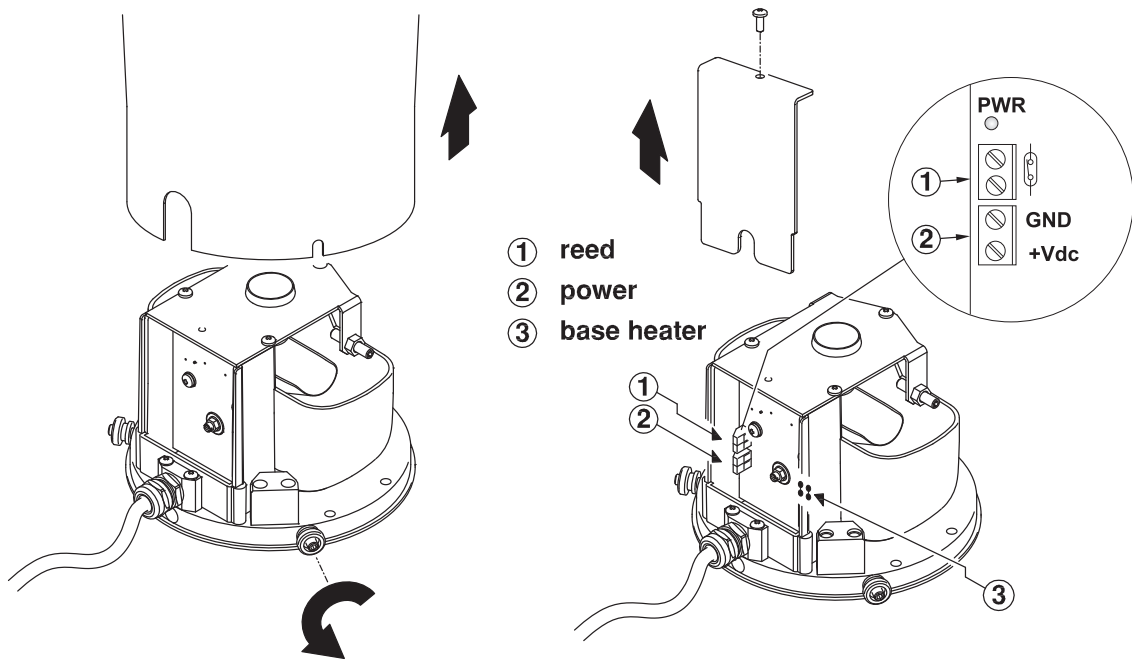

Fig. 3 – Electrical connections (version with heating system)

3.2 TIPPING BUCKET

The tipping bucket is locked for the transport of the rain gauge. To unlock the bucket, remove the holders as shown in fig.4.

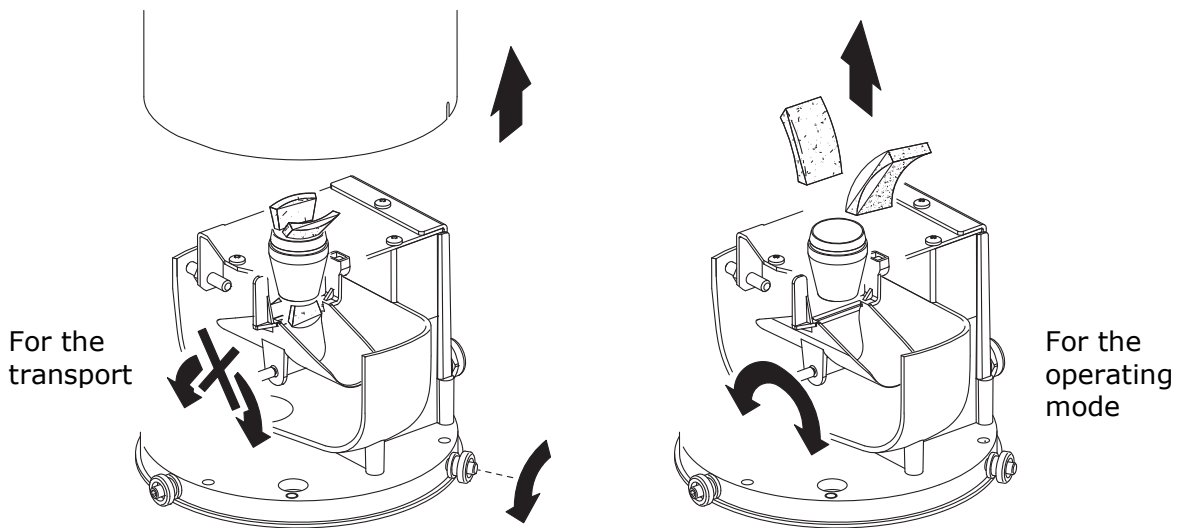

Fig. 4 – Locking and unlocking the tipping bucket

The oscillation of the tipping bucket can be adjusted through the two threaded rods located at the sides of the bucket, as illustrated in fig. 5.

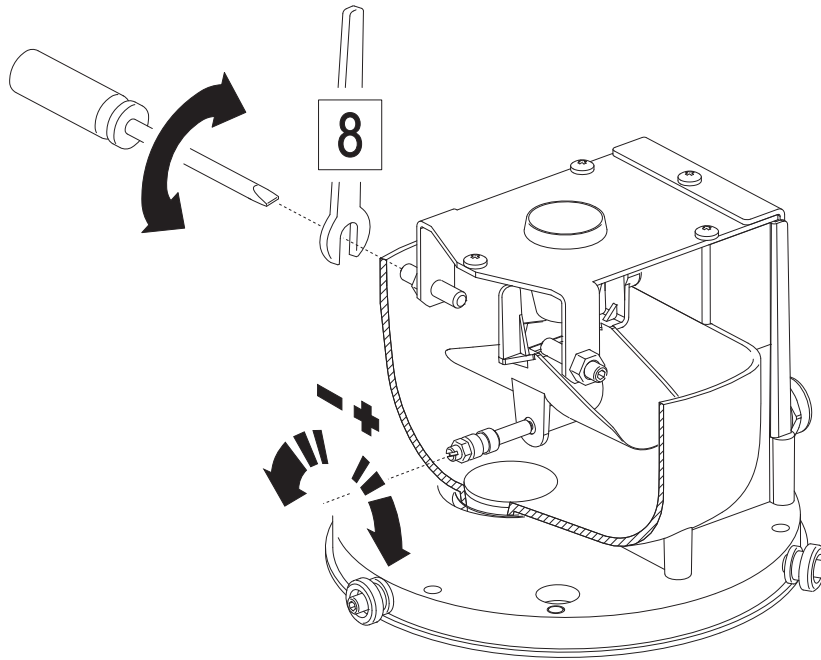

Fig. 5 – Adjustment of the tipping bucket

3.3 INSTALLATION MODES

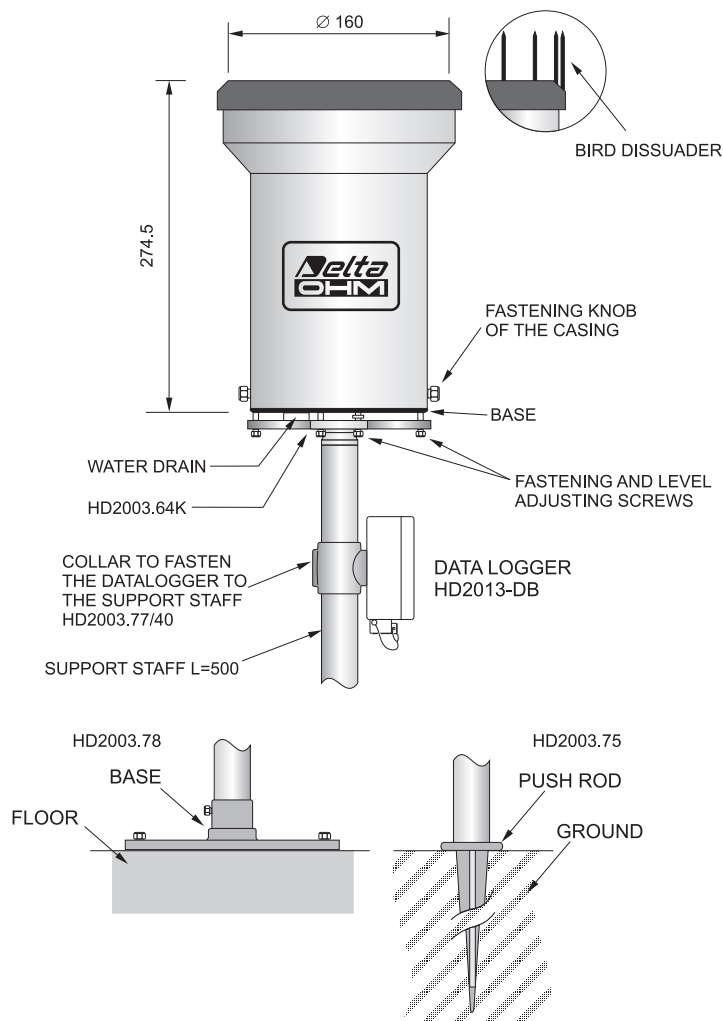

Fig. 6 – Mechanical dimensions, installation modes

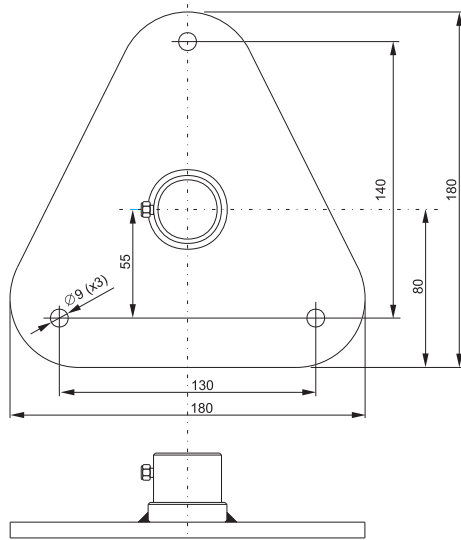

Fig. 7 – Base for ground fastening (HD2003.78)

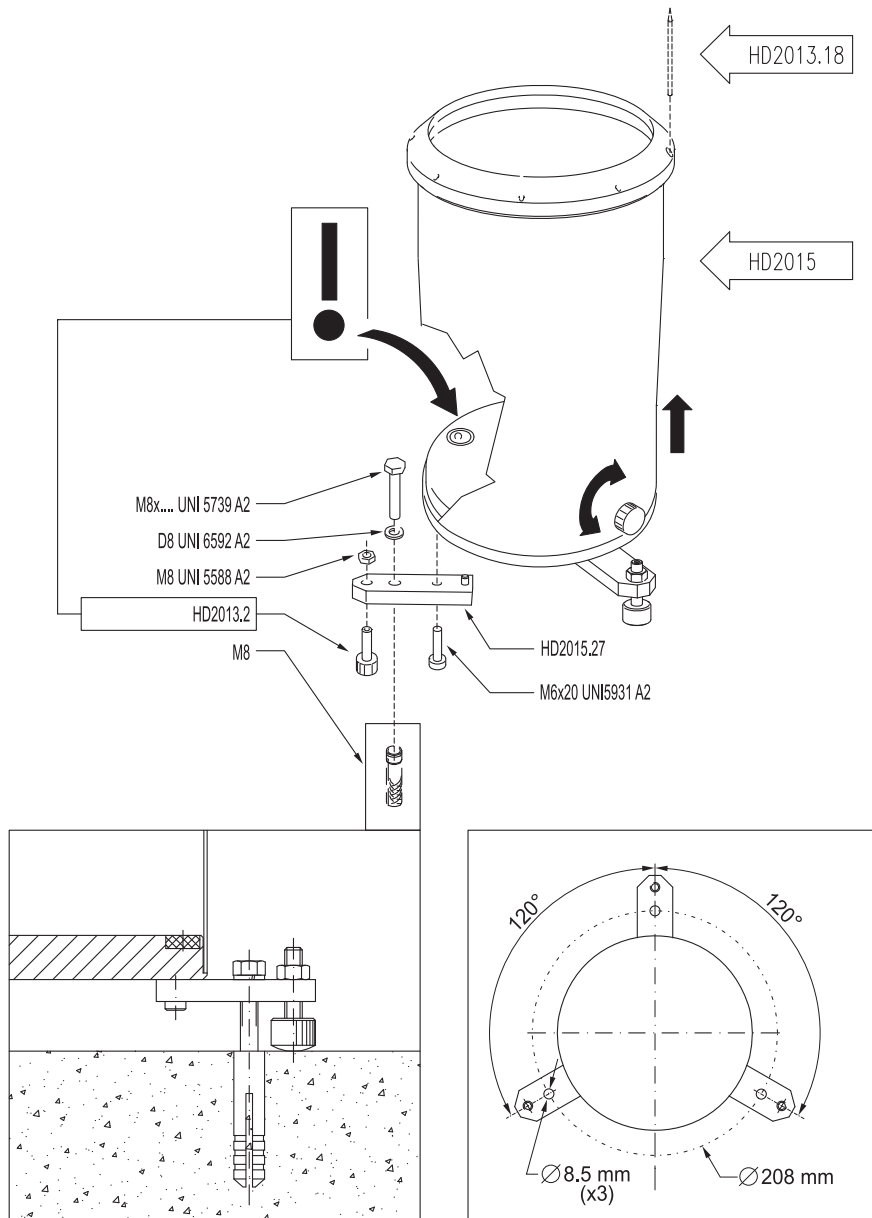

Fig. 8 – Ground installation

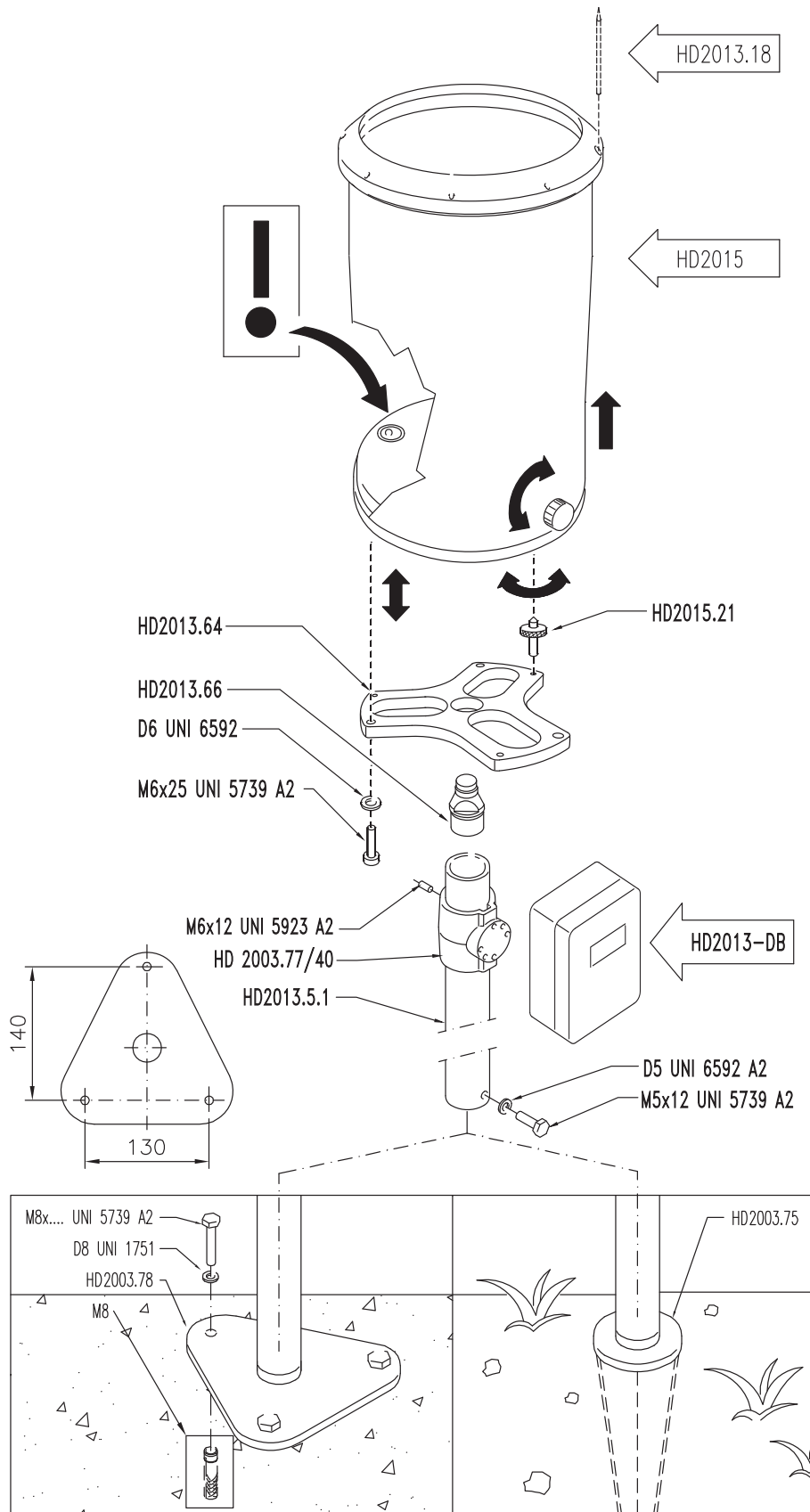

Fig. 9 – Installation raised above ground

4 MAINTENANCE

Verify filter cleanliness periodically; check that there is no debris, leaves, dirt in the lower filter or anything else that might obstruct the flowing of water. Check that the tipping bucket contains no deposits of dirt, sand or any other obstruction. If necessary, the surfaces can be cleaned with non aggressive detergent.

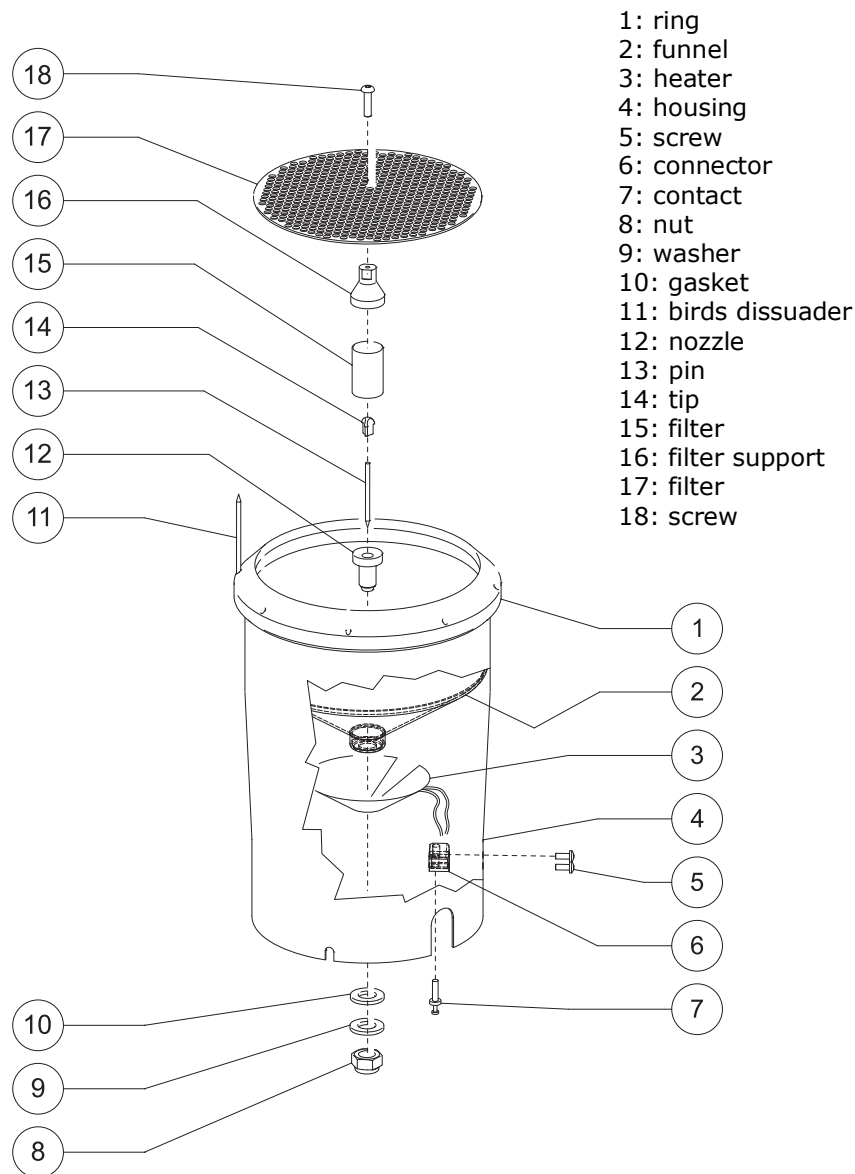

Fig. 10 – Exploded view of the upper part (version with heating)

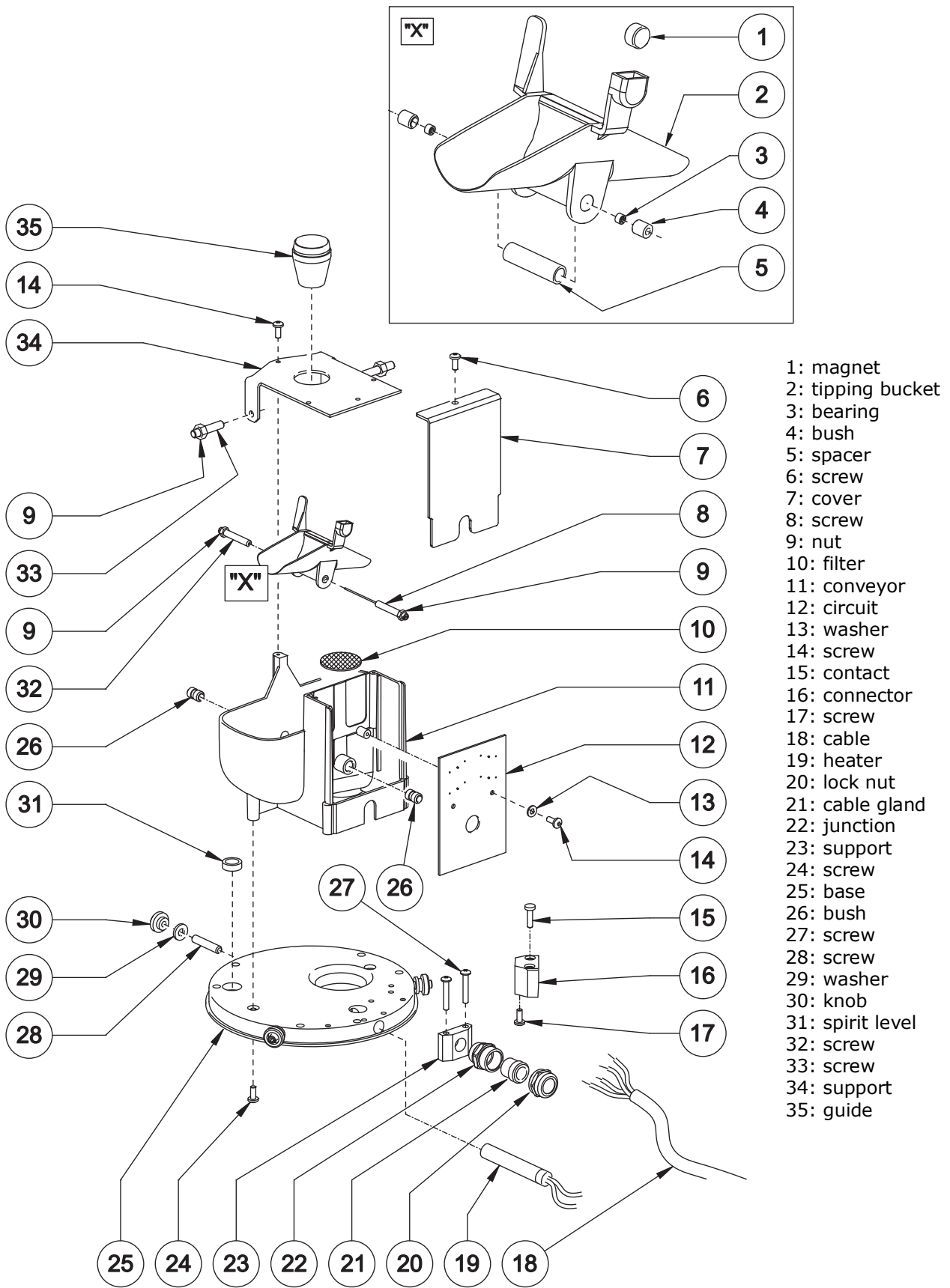

Fig. 11 – Exploded view of the lower part (version with heating)

5 INSTRUMENT STORAGE

Instrument storage conditions:

- Temperature: -30...+70 °C.
- Humidity: less than 90 %RH no condensation.
- In storage, avoid places where:
 - humidity is high;
 - the instrument is exposed to direct sun radiation;
 - the instrument is exposed to a high temperature source;
 - high vibration levels are present;
 - the instrument may be exposed to vapor, salt and/or corrosive gas.

6 SAFETY INSTRUCTIONS

General safety instructions

The instrument has been manufactured and tested in accordance with the safety standard EN61010-1:2010 "Safety requirements for electrical equipment for measurement, control and laboratory use" and has left the factory in perfect safety technical conditions.

The instrument proper operation and operating safety can be ensured only if all standard safety measures as well as the specific measures described in this manual are followed.

The instrument proper operation and operating safety can be ensured only in the climatic conditions specified in this manual.

Do not use the instruments in places where there are:

- Corrosive or flammable gases.
- Direct vibrations or shocks to the instrument.
- High-intensity electromagnetic fields, static electricity.

Do not remove the cylindrical cover of the instrument before unplugging the power cable of the heater.

Ensure that there is the system ground (Protective Earth) and the connecting cable is in good condition.

User obligations

The instrument operator shall follow the directives and regulations below that refer to the treatment of dangerous materials:

- EEC directives on workplace safety.
- National law regulations on workplace safety.
- Accident prevention regulations.

7 ORDERING CODES

- HD2015** Tipping bucket rain gauge, area 200 cm², for temperatures from +4 °C to +70 °C. **Resolution to be specified upon request at the time of placing the order:** 0.1 – 0.2 or 0.5 mm. Output contact normally closed.
- HD2015R** Tipping bucket rain gauge, area 200 cm², with heating system for temperatures from -20 °C to +70 °C. **Resolution to be specified upon request at the time of placing the order:** 0.1 – 0.2 or 0.5 mm. Output contact normally closed. Power supply voltage: 12 Vdc or 24 Vdc ± 10% (to be specified at the time of placing the order) / absorbed power 50 W.
- HD2013.18** Bird dissuader.
- HD2015.5K** Kit of accessories for the installation of the rain gauge raised 500 mm off the ground (HD2013.5.1 + HD2013.64 + HD2013.66).
- HD2015.5K.1** Kit of accessories for the installation of the rain gauge raised 1 m off the ground (HD2013.5.3 + HD2013.64 + HD2013.66).
- HD2003.75** Base with tip for the ground to support the rain gauge installed off the ground.
- HD2003.78** Flat base for fastening the support of the rain gauge raised above ground.

DELTA OHM metrology laboratories LAT N° 124 are ISO/IEC 17025 accredited by ACCREDIA for Temperature, Humidity, Pressure, Photometry / Radiometry, Acoustics and Air Velocity. They can supply calibration certificates for the accredited quantities.

**DICHIARAZIONE DI CONFORMITÀ UE
EU DECLARATION OF CONFORMITY****Delta Ohm S.r.L. a socio unico – Via Marconi 5 – 35030 Caselle di Selvazzano – Padova – ITALY**Documento Nr. / Mese.Anno: **5129 / 01.2019**
Document-No. / Month.Year :

Si dichiara con la presente, in qualità di produttore e sotto la propria responsabilità esclusiva, che i seguenti prodotti sono conformi ai requisiti di protezione definiti nelle direttive del Consiglio Europeo:

*We declare as manufacturer herewith under our sole responsibility that the following products are in compliance with the protection requirements defined in the European Council directives:*Codice prodotto: **HD2015 – HD2015R**
Product identifier :Descrizione prodotto: **Pluviometro a vaschetta basculante**
Product description : **Tipping bucket rain gauge**I prodotti sono conformi alle seguenti Direttive Europee:
The products conform to following European Directives:

Direttive / Directives	
2014/30/EU	Direttiva EMC / EMC Directive
2014/35/EU	Direttiva bassa tensione / Low Voltage Directive
2011/65/EU	RoHS / RoHS

Norme armonizzate applicate o riferimento a specifiche tecniche:
Applied harmonized standards or mentioned technical specifications:

Norme armonizzate / Harmonized standards	
EN 61010-1:2010	Requisiti di sicurezza elettrica / Electrical safety requirements
EN 61326-1:2013	Requisiti EMC / EMC requirements
EN 50581:2012	RoHS / RoHS

Il produttore è responsabile per la dichiarazione rilasciata da:
The manufacturer is responsible for the declaration released by:

Johannes Overhues

Amministratore delegato
Chief Executive Officer

Caselle di Selvazzano, 03/01/2019

Questa dichiarazione certifica l'accordo con la legislazione armonizzata menzionata, non costituisce tuttavia garanzia delle caratteristiche.

This declaration certifies the agreement with the harmonization legislation mentioned, contained however no warranty of characteristics.

GUARANTEE



Member of GHM GROUP

TERMS OF GUARANTEE

All DELTA OHM instruments are subject to accurate testing, and are guaranteed for 24 months from the date of purchase. DELTA OHM will repair or replace free of charge the parts that, within the warranty period, shall be deemed non efficient according to its own judgement. Complete replacement is excluded and no damage claims are accepted. The DELTA OHM guarantee only covers instrument repair. The guarantee is void in case of incidental breakage during transport, negligence, misuse, connection to a different voltage than that required for the appliance by the operator. Finally, a product repaired or tampered by unauthorized third parties is excluded from the guarantee. The instrument shall be returned FREE OF SHIPMENT CHARGES to your dealer. The jurisdiction of Padua applies in any dispute.

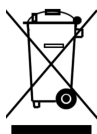

The electrical and electronic equipment marked with this symbol cannot be disposed of in public landfills. According to the Directive 2011/65/EU, the european users of electrical and electronic equipment can return it to the dealer or manufacturer upon purchase of a new one. The illegal disposal of electrical and electronic equipment is punished with an administrative fine.

This guarantee must be sent together with the instrument to our service centre.
IMPORTANT: Guarantee is valid only if coupon has been correctly filled in all details.

Instrument Code: **HD2015** **HD2015R**

Serial Number _____

RENEWALS

Date _____

Date _____

Inspector _____

Inspector _____

Date _____

Date _____

Inspector _____

Inspector _____

Date _____

Date _____

Inspector _____

Inspector _____



The quality level of our instruments is the result of the constant development of the product. This may produce some differences between the information written in this manual and the instrument you have purchased. We cannot completely exclude the possibility of errors in the manual, for which we apologize.

The data, images and descriptions included in this manual cannot be legally asserted. We reserve the right to make changes and corrections with no prior notice.

V1.0
03/01/2019